

## Operating Instructions

### Compact Tube Furnace

R 50/250/12 - R 120/1000/13

-> 06.2007

Original instructions

■ Made  
■ in  
■ Germany

[www.nabertherm.com](http://www.nabertherm.com)

---

### **Copyright**

© Copyright by  
Nabertherm GmbH  
Bahnhofstrasse 20  
28865 Lilienthal  
Federal Republic of Germany

Reg: M01.0006 ENGLISCH  
Rev: 2013-04

No responsibility is accepted for the correctness of this information. We reserve the right to make technical alterations.

<b>1</b>	<b>Introduction .....</b>	<b>5</b>
1.1	Product Description.....	6
1.2	Overview of the Complete Furnace.....	7
1.2.1	Key to the Model Names .....	8
1.3	Safeguarding against Dangers Posed by Over-Temperature.....	9
1.4	Scope of Delivery.....	10
<b>2</b>	<b>Specifications .....</b>	<b>11</b>
2.1	Warranty and Liability .....	13
<b>3</b>	<b>Safety .....</b>	<b>14</b>
3.1	Intended Use.....	14
3.2	Requirements for the Furnace Operator .....	15
3.3	Requirements for the Operating Personnel.....	16
3.4	Protective Clothing.....	17
3.5	Basic Measures During Normal Operation .....	17
3.6	Basic Measures in Case of Emergency .....	18
3.6.1	What to do in an Emergency.....	18
3.7	Basic Measures for Servicing and Maintenance.....	19
3.8	Environmental Regulations.....	20
3.9	Explanation of the Symbols and Warnings .....	21
3.10	General Risks with the Furnace.....	24
<b>4</b>	<b>Transportation, Installation, and Commissioning.....</b>	<b>25</b>
4.1	Delivery.....	25
4.2	Unpacking .....	27
4.3	Transportation Securing Equipment/Packaging.....	29
4.4	Constructional and Connection Requirements .....	29
4.4.1	Installation (Furnace Location).....	29
4.5	Assembly, Installation, and Connection.....	31
4.5.1	Venting Exhaust Fumes .....	31
4.5.2	Connecting the Furnace to the Power Supply.....	32
4.5.3	Inserting/Introducing the Working Tube .....	34
4.6	Commissioning .....	35
4.7	Recommendations for Heating the Furnace for the First Time .....	36
4.8	Maximum permissible heating rates.....	36
<b>5</b>	<b>Operation .....</b>	<b>37</b>
5.1	Maximum permissible heating rates.....	37
5.2	Loading/Charging .....	38
<b>6</b>	<b>Servicing, Cleaning, and Maintenance .....</b>	<b>38</b>
6.1	Shutting the System Down for Maintenance.....	40
6.2	Regular Maintenance of the Furnace.....	41
6.3	Operating and Auxiliary Materials.....	43
6.4	Cleaning Products .....	43
<b>7</b>	<b>Malfunctions .....</b>	<b>44</b>
<b>8</b>	<b>Spare Parts/Wearing Parts .....</b>	<b>45</b>
8.1	Repairing the Insulation .....	48

---

<b>9</b>	<b>Accessories (Options)</b> .....	<b>48</b>
9.1	Laboratory Gas Supply Station .....	48
9.2	Over-temperature Limit Controller .....	48
9.3	Available Working Tubes .....	49
<b>10</b>	<b>Electrical Connections (Circuit Diagram)</b> .....	<b>50</b>
<b>11</b>	<b>Nabertherm Service</b> .....	<b>54</b>
<b>12</b>	<b>Shut-Down, Dismantling, and Storage</b> .....	<b>55</b>
12.1	Transportation/Return Transportation .....	56
<b>13</b>	<b>Declaration of Conformity</b> .....	<b>57</b>
<b>14</b>	<b>Glossary</b> .....	<b>58</b>
<b>15</b>	<b>For Your Notes</b> .....	<b>59</b>

## 1 Introduction

### Dear Customer,

Thank you for choosing a quality product from Nabertherm GmbH.

You can be proud that you have chosen a furnace which has been especially tailored to suit your manufacturing and production conditions.

This product is characterized by

- professional workmanship
- high performance due to its high efficiency
- high-quality insulation
- low power consumption
- low noise level
- simple installation
- easy to maintain
- high availability of spare parts

Your Nabertherm Team



#### Note

These documents are intended only for buyers of our products and may not be copied or disclosed to third parties without our written consent.

(Law governing copyright and associated protective rights, German Copyright Law from Sept. 9, 1965)

#### Protective Rights

Nabertherm GmbH owns all rights to drawings, other documents and authorizations, also in case of applications for protective rights.



#### Note

All the figures in the instructions have a descriptive character; in other words, they do not represent the exact details of the furnace.



#### Note

The pictures contained in the instruction manual may contain inaccuracies in terms of the function, design and furnace model.

## 1.1 Product Description



You have acquired a high-quality product which, when properly cared for and maintained, will give you many years of reliable service. One basic prerequisite is that the furnace is used the way it was designed to be used.

During development and production a high priority was placed on safety, functionality and economy.

### Compact Tube Furnaces Model Series R

Table tube furnaces of model series R with integrated switching and control system can be universally used for many processes. The tube furnace is standard-equipped with a working tube made from material C 530 and with two fiber plugs. High-quality insulation materials made of fiber plates allow energy-saving operation and short heating times thanks to the low heat storage and thermal conductivity. Table tube furnaces attain maximum furnace chamber temperatures of 1200 °C or 1300 °C.

#### This product has the following additional features:

- Rust-free housing made of structural stainless sheet steel
- Tube outside diameter up to 120 mm, heated lengths 250 to 1000 mm
- Working tube made of material C 530 including two fiber plugs as standard. Standard working tube according to table: see section on "Accessories"
- Wear-free thermocouple type S
- Noiseless, electronic relay

#### Optional Features

- Over-temperature limit controller with adjustable cutoff temperature for thermal safety class 2 in accordance with EN 60519-2 as over-temperature protection for furnace and product
- Cascade control with temperature measurement in the working tube and behind the tube
- Working tubes designed to meet process requirements
- Three-zone version with HiProSystem control (as of 750 mm heated length, with 1300 °C models)
- Other accessories: see section on "Accessories"

## 1.2 Overview of the Complete Furnace

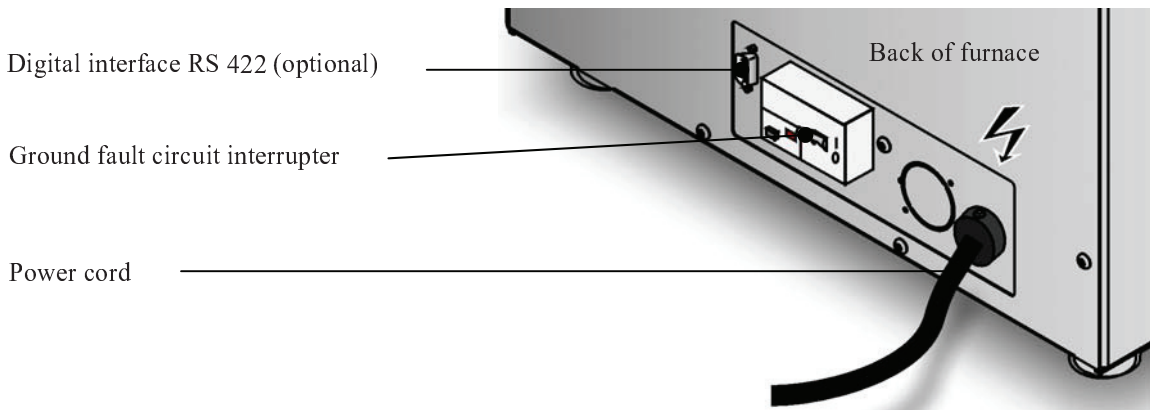
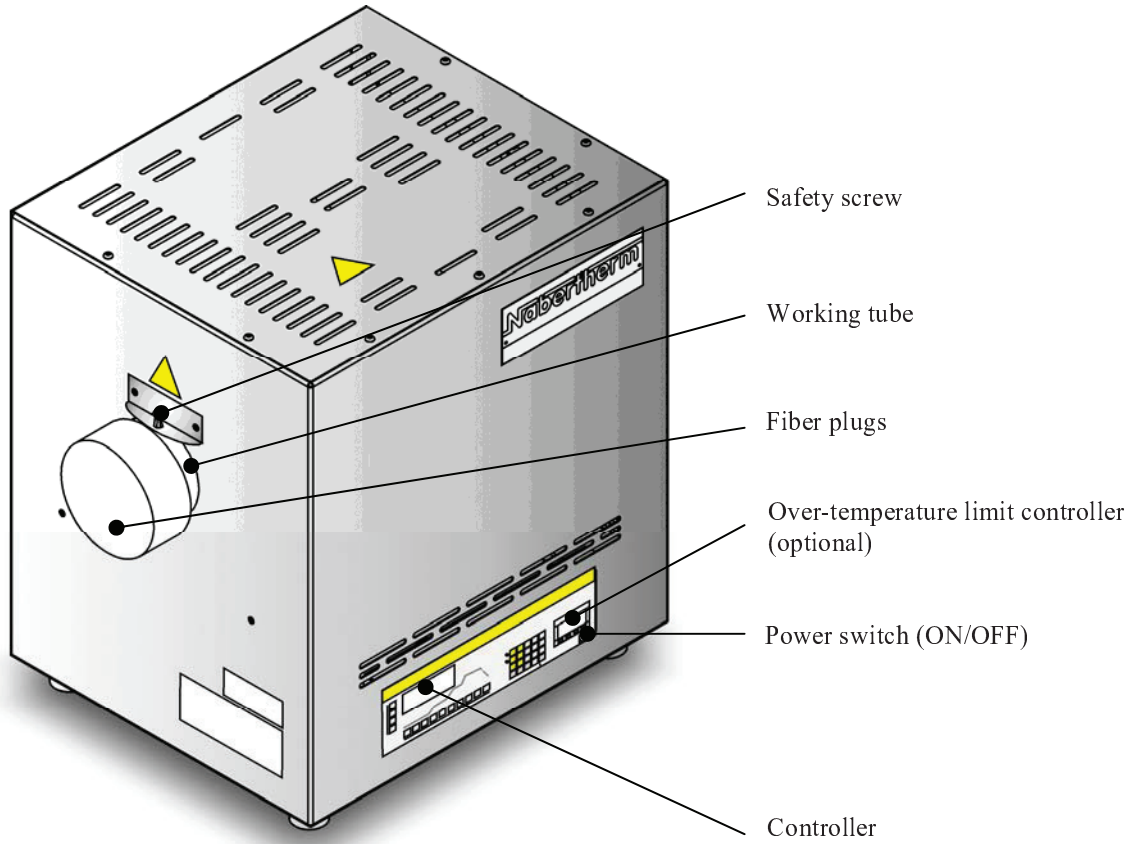

Fig. 1: Overall view: Compact Tube Furnace R ..../.. with controller  
 (Figure shows special version with over-temperature limit controller and interface RS 422)

## 1.2.1 Key to the Model Names

Example	Explanation
R 120/1000/12-B180 └───────────┘	<b>R</b> = Compact Tube Furnace
R <b>120</b> /1000/12-B180 └───────────┘	<b>120</b> = max. possible tube outside diameter in mm
R 120/ <b>1000</b> /12-B180 └───────────┘	<b>1000</b> = heated tube length in mm
R 120/1000/ <b>12</b> -B180 └───────────┘	<b>12</b> = Tmax 1200°C <b>13</b> = Tmax 1300°C
R 120/1000/12- <b>B180</b> └───────────┘	Controller model

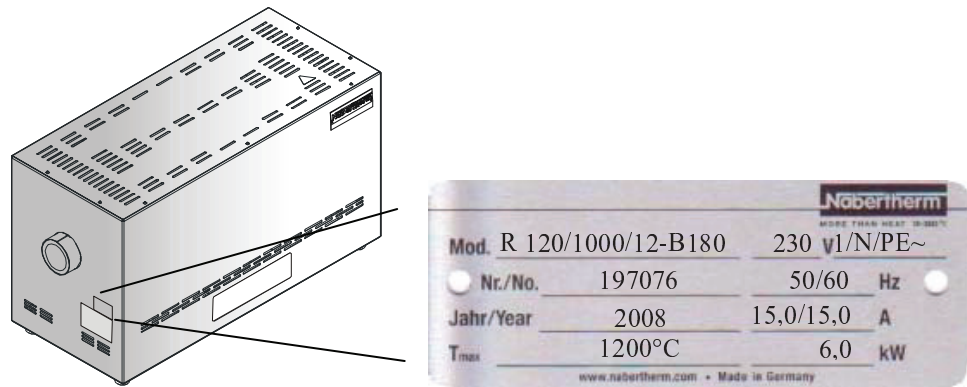



Fig. 2: Sample model designation (rating plate)



### 1.3 Safeguarding against Dangers Posed by Over-Temperature

Furnaces made by Nabertherm GmbH come with an over-temperature limiter with manual reset/with automatic reset to protect the furnace chamber against over-temperature as a **standard feature**.

The over-temperature limiter with manual reset/with automatic reset monitors the furnace chamber temperature. The display shows the most recently set cut-off temperature. If the furnace chamber temperature rises about the pre-set cut-off temperature the heating is shut down to protect the furnace, the charge and/or the operating equipment.

	 <b>DANGER</b>
	<ul style="list-style-type: none"> <li>• <b>Danger caused by incorrectly entered cut-off temperature at the over-temperature limiter with manual reset/over-temperature limiter with automatic reset.</b></li> <li>• <b>Mortal danger</b></li> </ul> <p>If, as a result of over-temperature from the charge and/or the operating equipment, a charge is likely to be damaged at this pre-set cut-off temperature of the over-temperature limiter with manual reset/over-temperature limiter with automatic reset, or if the charge itself becomes a source of danger for the furnace or its surroundings, the cut-off temperature must be reduced at the over-temperature limiter with manual reset/automatic reset to the maximum permissible value.</p>

Read the operating instructions of the over-temperature limiter with manual reset/with automatic reset before starting the furnace. The safety sticker must be removed from the over-temperature limiter with manual reset/with automatic reset. Any time a change is made in the heat treatment program, the maximum permissible cut-off temperature (alarm trigger temperature) at the over-temperature limiter with manual reset/with automatic reset must be checked or re-entered.

We recommend setting the maximum setpoint temperature of the heating program in the limiter between 5 °C and 30 °C, depending on the physical characteristics of the furnace, below the trigger temperature of the over-temperature limiter with manual reset/with automatic reset. This prevents an unwanted triggering of the over-temperature limiter with manual reset/with automatic reset.

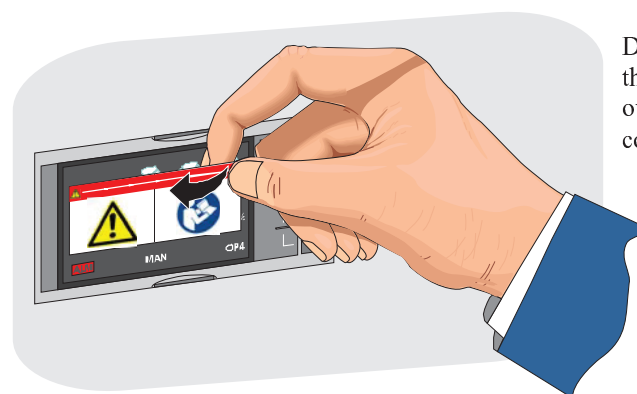

Description and function, see the Operating Instructions of the over-temperature limit controller/guard

Fig. 3: Removing the sticker

## 1.4 Scope of Delivery

The scope of supply includes the following components:

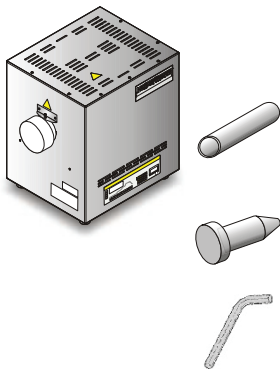

System Component	Quantity	Comment
<b>Compact Tube Furnace Model R</b>	1 x	Nabertherm GmbH
Standard working tube	1 x	Nabertherm GmbH
Fiber plugs	2 x	Nabertherm GmbH
Allen wrench	1 x	Nabertherm GmbH
- - -	- - -	- - -
Other components depending on variant	- - -	See delivery documents

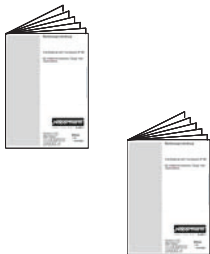

Document Type	Quantity	Comment
Operating instructions for Compact Tube Furnace Model R	1 x	Nabertherm GmbH
Controller operating instructions	1 x	Nabertherm GmbH
Operating instructions for 2108i over-temperature limit controller *)	1 x	Eurotherm GmbH
- - -	- - -	- - -
Other documents depending on variant	1 x	See the documentation folder

\*) = in scope of delivery depending on variant



### Note

Please keep all documents in a safe place. All of the functions of this furnace system have been tested during fabrication and before delivery.

## 2 Specifications



Electrical specifications are on the type plate located on the side of the furnace.

### Compact Tube Furnace

Model	Exterior dimensions in mm			Max. tube Ø outside/mm	Tube length mm	Heated length mm	Power kW	Length constant temperature ΔT 10K	Weight in kg
	W	D	H						
R 50/250/12	400	240	490	50	450	250	1.2	80	20
R 50/500/12	650	240	490	50	700	500	1.8	170	25
R 100/750/12	1000	360	640	100	1070	750	3.6	250	80
R 120/1000/12	1300	420	730	120	1400	1000	6.0	330	170
R 50/250/13	400	40	490	50	450	250	1.3	80	35
R 50/500/13	650	240	490	50	700	500	1.9	170	48
R 100/750/13	1000	360	640	100	1070	750	4.4	250	120
R 120/1000/13	1300	420	730	120	1400	1000	6.5	330	230

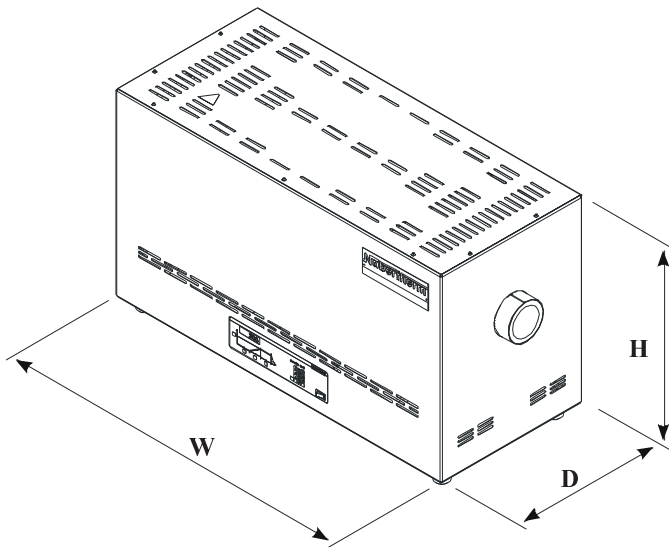

Fig. 4: Dimensions of Compact Tube Furnaces, Model R

<b>Electrical Connection</b>		<b>1-phase:</b>	<b>3-phase:</b>
	Model:	<b>R</b> 50/250/12 <b>R</b> 50/500/12 <b>R</b> 100/750/12 <b>R</b> 50/250/13 <b>R</b> 50/500/13	<b>R</b> 120/1000/12 <b>R</b> 100/750/13 <sup>2)</sup> <b>R</b> 120/1000/13 <sup>2)</sup>
	Voltage:	110 V – 240 V	200 V – 240 V or 380 V – 480 V
	Frequency:	50 Hz or 60 Hz	50 Hz or 60 Hz
<b>Thermal Protection Class</b>	Furnaces:	<b>as per DIN EN 60519-2</b> without safety controller: Class 0 with safety controller: Class 2	
<b>Protection class</b>	Furnaces:	IP20	
	Switching cabinet:	IP43	
<b>Ambient conditions for electrical equipment</b>	Temperature: Humidity:	+5°C to +40°C, max. 80% noncondensing	
<b>Weight</b>	Switching system	Depending on model (see delivery documents)	
1) Heating only at one phase      2) Heating only between two phases			
<b>Emissions</b>	Continuous sound pressure level:	< 80 dB(A)	

## 2.1 Warranty and Liability



**As regards warranty and liability, the normal Nabertherm warranty terms apply, unless individual terms and conditions have been agreed. However, the following conditions also apply:**

Warranty and liability claims for personal injury or damage to property shall be excluded if they are attributable to one or more of the following causes:

- Everyone involved in operation, installation, maintenance, or repair of the furnace must have read and understood the operating instructions. No liability will be accepted for damage or disruptions to operation resulting from non-compliance with the operating instructions.
- Not using the furnace as intended,
- Improper installation, start-up, operation, or maintenance of the furnace,
- Operation of the furnace with defective safety equipment or improperly installed or non-functioning safety and protective equipment,
- Not observing the references in the operating instructions to transportation, storage, installation, start-up, operation, maintenance, or equipping the furnace,
- Making unauthorized changes to the furnace,
- Making unauthorized changes to the operating parameters,
- Making unauthorized changes to the parameterization, the settings, or the program,
- Original parts and accessories are designed especially for Nabertherm furnaces. Replace parts only with original Nabertherm parts. Otherwise the warranty will be void. Nabertherm accepts absolutely no liability for damage caused by using parts that are not original Nabertherm parts.
- Catastrophes due to third-party causes and force majeure.

## 3 Safety

### 3.1 Intended Use



This Nabertherm system was designed and manufactured after careful selection of the harmonized standards to be observed plus other technical specifications. It therefore corresponds to the state of the art, ensuring the highest possible degree of safety.

Only materials with known characteristics and melting temperatures may be used. Check the material safety data sheets if necessary.

Use of the furnace for any other purpose whatsoever such as processing products other than those intended or handling hazardous substances or substances posing a health hazard constitutes improper use and must be agreed upon with Nabertherm in writing.

Whether or not the materials used in the furnace can potentially corrode or destroy the insulation or heating elements must be ascertained.

For furnaces with over-temperature limit controllers, the cutoff temperature must be set to prevent overheating of the material.

Modifications to system equipment must be agreed upon with Nabertherm in writing. It is not permitted to remove, bypass, or shut down safety devices.

The installation instructions and safety guidelines must be observed. Otherwise, the furnace will not be considered as being used as designated, and all claims against Nabertherm GmbH will be void.

Removal of the fiber plugs, flange and protective cover when hot (> 400°C) is prohibited. The resulting thermal shock will otherwise destroy the working tube and possibly the heating elements as well.

Operating with power sources, products, operating equipment, additives, etc., which are subject to the Ordinance on Hazardous Substances or causing risks to the health of operating personnel in any way is not permitted.



- This furnace is designed for **commercial** use. The furnace must **not** be used for warming animals, wood, grain, etc.
- The heating of food and drink for the purpose of consumption is not permitted.
- The furnace must not be used as a workplace heater.
- Do not use the furnace to melt ice or similar materials.
- Do not use the furnace for metal working.
- Do not use the furnace as a clothes dryer.



#### Note

See safety instructions in the individual sections.



#### Note

In Germany, the general accident protection guidelines of VBG or BGZ must be observed. The national accident prevention regulations of the country of operation apply.



**Caution**

Operating the furnace with explosive gases or mixtures, including explosive gases or mixtures created as a result of heating/drying, is prohibited.

This furnace features **no** safety technology for processes which produce combustible mixtures, for example debinding.

If the furnace is still used for such processes despite this fact, the concentration of organic gas mixtures in the furnace must never exceed 3% of the lower explosion limit (LEL). This pre-requisite applies not only to normal operation but, in particular, to exceptional situations such as process disruptions (caused, for example, by the failure of a power unit). You must ensure that the furnace is adequately ventilated and vented.

Nabertherm offers a broad range of furnaces which were especially developed for processes involving the use of combustible gas mixtures.



**Note**

This product does **not** comply with the ATEX Directive and may **not** be used in ignitable atmospheres. It must not be operated with explosive gases or mixtures or during processes where explosive gases or mixtures are produced.

### 3.2 Requirements for the Furnace Operator



The set-up instructions and safety regulations must be followed, otherwise the furnace will be deemed to have been used improperly, effectively cancelling any claims against Nabertherm GmbH.

This level of safety when operating the furnace can be achieved only if all the necessary measures have been taken. It depends on the furnace operator's diligence in planning these measures and controlling how they are carried out.

**The operator must ensure that**

- all harmful gases are removed from the workplace, for example by an extraction system,
- the extraction system is switched on,
- the workplace is properly ventilated,
- the furnace is operated only in a perfect operating condition and, in particular, that the functions of the safety components are checked regularly.
- the required personal protective equipment is available for and used by the operating, maintenance, and repair personnel.
- these operating instructions, including the supplier documentation, are kept near the furnace. These instructions must be available at all times for anyone working with or on the furnace;
- all the safety and operating instruction signs on the furnace can be read properly. Damaged or unreadable signs must be replaced immediately,
- furnace personnel are informed regularly about all issues involving occupational safety and environmental protection and are familiar with all the operating instructions, especially those involving safety,
- a risk assessment is carried out (in Germany, covered by Section 5 of the Occupational Safety Act) to determine any other hazards that may result from the working conditions particular to the furnace's location,
- all other instructions and safety guidelines that have been determined in a risk assessment for the workplace are compiled in an operation manual (in Germany,

covered by Section 6 of the Ordinance Regulating the Use of Operating Equipment).

- operating personnel still in training initially perform their work at the furnace under the supervision of an experienced person. Successful completion of the training period must be confirmed in writing.

### 3.3 Requirements for the Operating Personnel



The furnace may be operated only by persons who are trained, instructed, and authorized to do so. These persons must know the operating instructions and act accordingly. The authorizations of the operating personnel must be clearly defined.

Only adequately qualified and authorized persons may operate, maintain, or repair the furnace.

Operating personnel are instructed regularly in all aspects of occupational safety and environmental protection and are familiar with all the operating instructions, in particular, safety instructions.

Only trained personnel may operate the control and safety equipment.

#### The operator should complete these details:

- Operator

\_\_\_\_\_

- The furnace may only be transported by

\_\_\_\_\_

- The furnace may only be installed by

\_\_\_\_\_

- The furnace may only be commissioned by

\_\_\_\_\_

- Initial instructions may only be given by

\_\_\_\_\_

- Malfunctions may only be rectified by

\_\_\_\_\_

- The furnace may only be maintained by

\_\_\_\_\_

- The furnace may only be cleaned by

\_\_\_\_\_

- The furnace may only be serviced by

\_\_\_\_\_



- The furnace may only be repaired by

\_\_\_\_\_

- The furnace may only be shut down by

\_\_\_\_\_



	 <b>DANGER</b>
	<ul style="list-style-type: none"> <li>• <b>Danger caused by incorrectly entered cut-off temperature at the over-temperature limiter with manual reset/over-temperature limiter with automatic reset.</b></li> <li>• <b>Mortal danger</b></li> </ul> <p>If, as a result of over-temperature from the charge and/or the operating equipment, a charge is likely to be damaged at this pre-set cut-off temperature of the over-temperature limiter with manual reset/over-temperature limiter with automatic reset, or if the charge itself becomes a source of danger for the furnace or its surroundings, the cut-off temperature must be reduced at the over-temperature limiter with manual reset/automatic reset to the maximum permissible value.</p>

### 3.4 Protective Clothing



Everywhere in the vicinity of the furnace, pouring pans, and similar components, wear protective clothing which is resistant to splatters of molten metal.



Protect your hands by wearing heat-proof gloves.



Wear a respirator (P2 or higher) to protect your respiratory tract e.g. when working on the fiber insulation.

### 3.5 Basic Measures During Normal Operation



#### **Warning! General Hazards!**

Before turning on the system, check and be sure that only authorized personnel are in the working zone of the system and that no-one can be injured by operation of the system!!

Before every production start, check and be sure that all safety systems are functioning properly!

Before every production start, check the system for visible damage and be sure that it is only operated in perfect condition! Notify management immediately of any defects found!

Before every production start, remove all materials/objects from the working zone of the system which are not required for production!

The system may only be started from the designated work station (e.g. the PC/control console).

**At least once a day (see also Service and Maintenance), the following check tasks must be performed:**

- check the system for externally detectable damage,

- check the function of all safety systems (e.g. the EMERGENCY STOP system - if present in the system),
- check all hydraulic or pneumatic hoses for leaks and correct connection (if present in the system),
- check gas or oil lines for leaks and correct connection (if present in the system).

### 3.6 Basic Measures in Case of Emergency

#### 3.6.1 What to do in an Emergency



##### Note

**The power plug is to be pulled out to stop the furnace in case of an emergency.**

Therefore, the power plug must be accessible at all times when the furnace is operating so that it can be pulled out quickly in case of an emergency.



##### Risks during Normal Operation!

Switch the furnace off immediately in case of unexpected occurrences in the furnace (e.g. a lot of smoke or unusual smells). Wait until the furnace has cooled naturally to room temperature.



##### Warning - Danger of Electric Shock!

Work on the electrical equipment may be done only by qualified, authorized electricians.



##### Warning! General hazards!

In case of unexpected events in the furnace (e.g. severe smoking or annoying odor), fiber plugs at the working tube must **not** be opened or removed. Doing so creates a fire or explosion hazard. Wait until the furnace has naturally cooled down to room temperature.

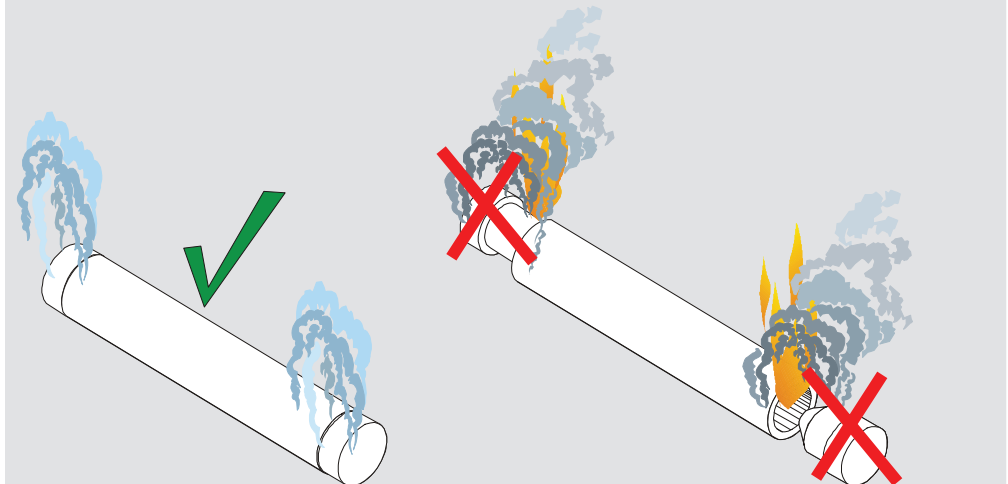

### 3.7 Basic Measures for Servicing and Maintenance



Maintenance work must be performed by authorized persons following the maintenance instructions and the accident prevention regulations. We recommend that the maintenance and repair work be carried out by the service team of Nabertherm GmbH. Non-compliance may cause injuries, death, or considerable damage to property.

Switch off the furnace and make sure it cannot be switched on again inadvertently (lock the main switch and secure it with a padlock), or pull out the power plug.

Clear an adequate area around the furnace to facilitate the repair work.

Suspended loads are dangerous. Working beneath a suspended load is prohibited. There is a risk of fatal injury.

Relieve the pressure on hydraulic equipment before carrying out maintenance or repair work (if applicable).

When cleaning furnaces, control cabinets, or electrical equipment housings, never spray them with water.

When maintenance or repair work has been completed, before recommencing production ensure the following:

- Check that loosened screw connections have been re-tightened,
- Reinstall protective equipment, screens, and filters,
- Remove all material, tools, and other equipment used for the maintenance or repair work from the working area of the furnace,
- Remove any liquids that have leaked,
- Check that all safety functions (e.g. emergency stop button) work properly,

Power cables may be replaced only with similar, approved cables.

### 3.8 Environmental Regulations

All statutory duties regarding waste avoidance, proper recycling, and disposal must be observed when work is carried out on and with the furnace.

Problem materials that are no longer needed, such as lubricants or batteries, must not be placed in normal waste disposal systems or allowed to enter the sewage system.

During installation, repair, and maintenance work, substances that are hazardous to water, such as

- lubricating grease and oils
- hydraulic oils
- refrigerants
- solvent-based cleaning fluids must not be allowed to contaminate the soil or enter the sewage system.

These substances must be stored, transported, collected, and disposed of in suitable containers.



#### Note

The operator must ensure that national environmental regulations are observed.

When it is delivered, this furnace contains no substances that make a hazardous waste classification necessary. However, residues of process materials may accumulate in the furnace insulation during operation. These may be hazardous to health and/or the environment.

- Dismantle the electronic components and dispose of them as electric scrap.
- Remove the insulation and dispose of it as hazardous waste (See Servicing, Cleaning, and Maintenance with Ceramic Fiber Material)
- Dispose of the housing as scrap metal.

### 3.9 Explanation of the Symbols and Warnings



**Note**

In the following operating instructions, specific warnings are given to draw attention to residual risks that cannot be avoided when the furnace is operating. These residual risks include dangers for humans/products/ the furnace, and the environment.

The symbols used in the operating instructions are especially intended to draw attention to safety information.

The symbols used cannot replace the text of the safety information. Therefore, always read the entire text.

Graphic symbols correspond to **ISO 3864**. In accordance with the American National Standard Institute (ANSI) **Z535.6** the following warning information and words are used in this document:



The general hazard symbol, in combination with the words **CAUTION**, **WARNING** and **DANGER** warns about the risk of serious injury. Observe the following information to prevent injury or death.

<b>NOTICE</b>	Refers to a hazard that could damage or destroy the equipment.
<b>CAUTION</b>	Refers to a hazard with a minor or medium risk of injury.
<b>WARNING</b>	Refers to a hazard that could cause death, serious or irreversible injury.
<b>DANGER</b>	Refers to a hazard that could directly cause death, serious or irreversible injury.

**Structure of the warning: All warnings are structured as follows**

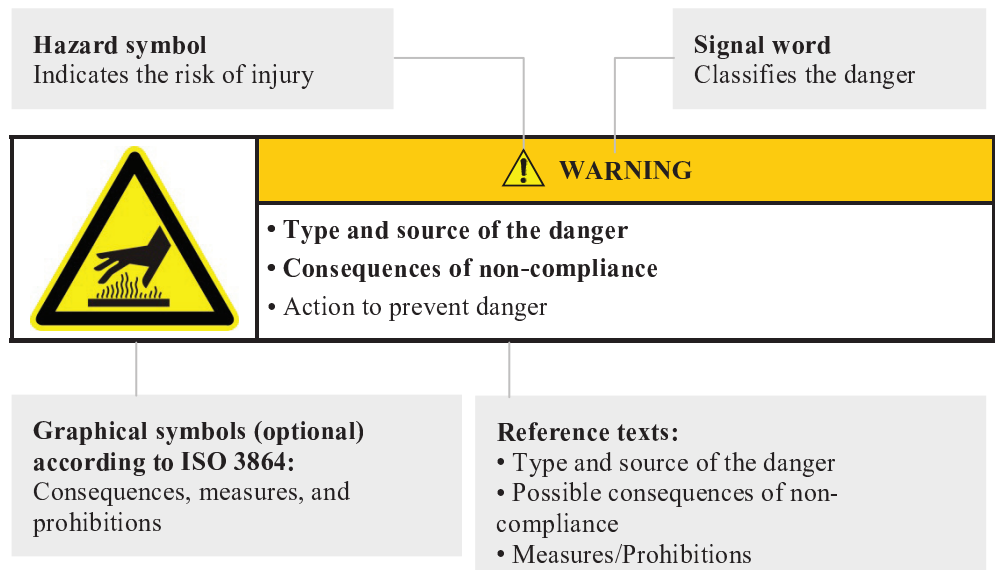

or

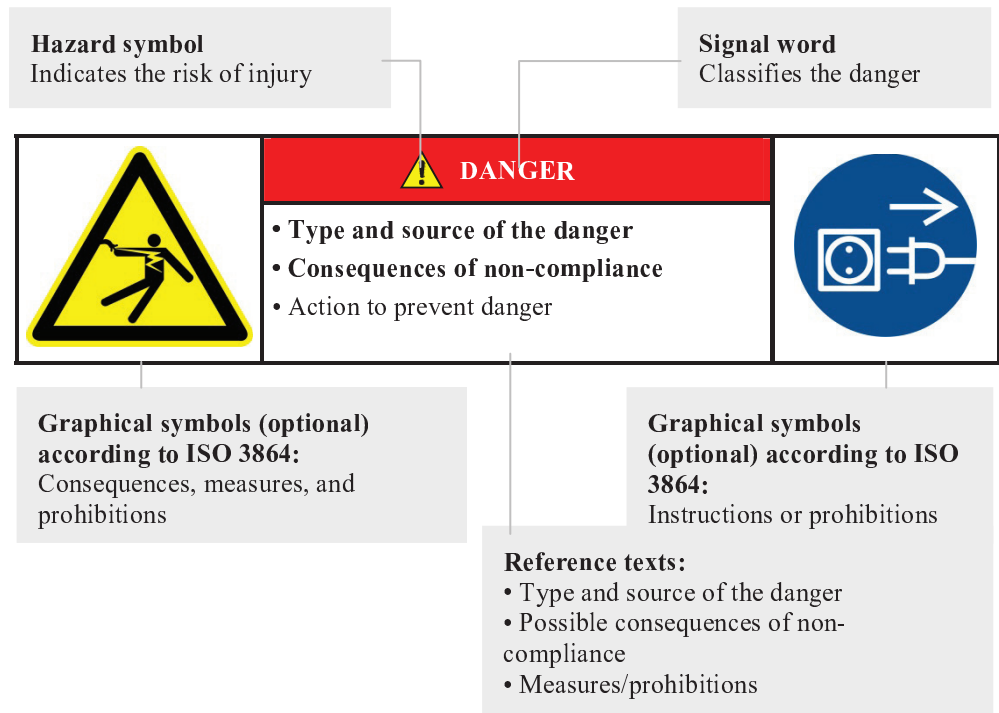

**Information Symbols in the Instructions:**

▶	<p><b>Note</b> Below this symbol you will find instructions and particularly useful information.</p>
ⓘ	<p><b>Rule - Rule Sign</b> This symbol draws attention to important rules that must be followed. Rule signs protect people against injury and show what is to be done in certain situations.</p>
📖	<p><b>Rule - Important Information for Operators</b> This symbol draws the operator's attention to important information and operating instructions that must be followed.</p>
🔧	<p><b>Rule - Important Information for Maintenance Personnel</b> This symbol draws the maintenance personnel's attention to important operating and maintenance instructions (service) that must be followed.</p>
🔌➡	<p><b>Rule - Pull Out the Power Plug</b> This symbol tells the operator to pull out the power plug.</p>
👥	<p><b>Rule - Lift only with Several People</b> This symbol draws the personnel's attention to the fact that this device may only be lifted and moved to its final destination by several people.</p>
⚠️	<p><b>Warning - Hot Surface, Do Not Touch</b> This symbol warns the operator that the surface is hot and should not be touched.</p>

**Warning - Danger of Electric Shock**

This symbol warns the operator that there is a risk of an electric shock if the following warnings are not heeded.

**Warning – Suspended Load**

This symbol warns the operator of potential dangers of suspended loads. Working below a suspended load is strictly forbidden. Ignoring this can lead to fatal injury.

**Warning – Danger if Heavy Loads Are Lifted**

This symbol warns the operator of the potential dangers of lifting heavy loads. Ignoring this can lead to injury.

**Warning – Risk to the Environment**

This symbol warns the operator of the risk to the environment if the following information is not heeded. The operator must ensure that national environmental regulations are observed.

**Warning - Fire Danger**

This symbol warns operators of the danger of fire if the following information is not followed.

**Warning – Risk of Explosive Substances or Explosive Atmosphere**

These symbols warn the operator of explosive substances or an explosive atmosphere

**Prohibited - Important Information for Operators**

This symbol warns the operator that water or cleaning products must NOT be poured over the objects. A high-pressure cleaning device must also not be used.

**Warning Signs on the Furnace:****Warning - Hot Surface, Danger of Burning – Do Not Touch**

You may not always realize that surfaces, such as furnace components, furnace walls, doors and materials, and even liquids are hot. Do not touch the surface.

**Warning - Danger of Electric Shock!**

Warning, dangerous electric voltage

### 3.10 General Risks with the Furnace



#### Warning! General hazards!

- Risk of burning on the furnace housing and on the tube
- The door handle/grip can become very hot during operation; wear gloves.
- Risk of crushing on moving parts (door hinge, rotary tube drive, lifting table, etc.)
- The switchgear cabinet (if present) and the terminal boxes on the system contain dangerous electrical voltages.
- Do not insert any objects into the openings on the furnace housing, exhaust air holes, or cooling slots on the switchgear or furnace (if present). This poses a risk of electric shock.



#### Warning! General hazards!

No objects may be placed or set down on the furnace or switchgear. Doing so creates a fire or explosion hazard.

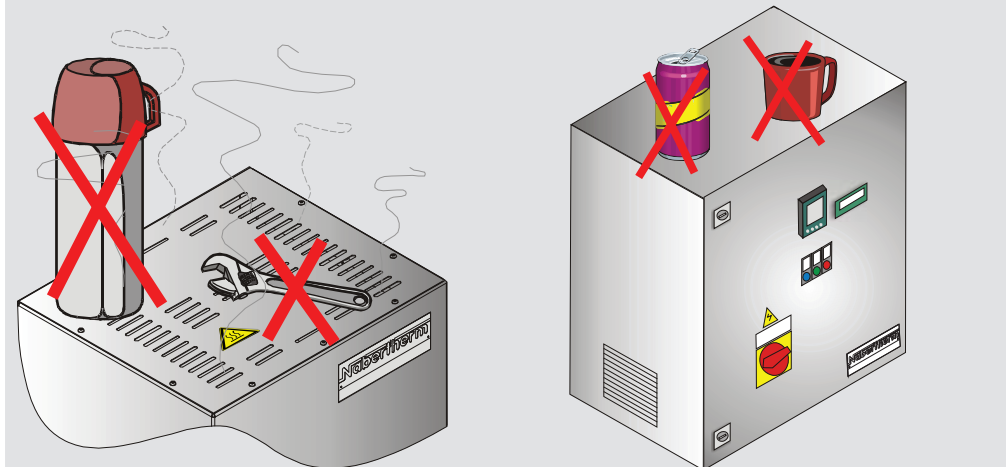

<b>DANGER</b>	
	<ul style="list-style-type: none"> <li>• <b>Danger caused by incorrectly entered cut-off temperature at the over-temperature limiter with manual reset/over-temperature limiter with automatic reset.</b></li> <li>• <b>Mortal danger</b></li> </ul>
	<p>If, as a result of over-temperature from the charge and/or the operating equipment, a charge is likely to be damaged at this pre-set cut-off temperature of the over-temperature limiter with manual reset/over-temperature limiter with automatic reset, or if the charge itself becomes a source of danger for the furnace or its surroundings, the cut-off temperature must be reduced at the over-temperature limiter with manual reset/automatic reset to the maximum permissible value.</p>





**Warning! General hazards!**

In case of unexpected events in the furnace (e.g. severe smoking or annoying odor), fiber plugs at the working tube must **not** be opened or removed. Doing so creates a fire or explosion hazard. Wait until the furnace has naturally cooled down to room temperature.



**4 Transportation, Installation, and Commissioning**

**4.1 Delivery**

**Check that Everything is Complete**

Compare the delivered items with the delivery note and the purchase order documents.

**Immediately** notify the carrier and Nabertherm GmbH of any missing or damaged parts, as complaints at a later date cannot be acknowledged.

**Danger of Injury**

When the furnace is being lifted, parts of the furnace or the furnace itself could topple over, slip, or fall. Before the furnace is lifted, make sure no one is in the working area. Wear safety footwear and a hard hat.

**Safety Instructions**

- Forklifts must be operated only by authorized personnel. The operator bears sole responsibility for safe operation and the load.
- When the furnace is being lifted, make sure that the ends of the forks or the load do not catch on neighboring goods. Use a crane to move tall parts, such as control cabinets.
- Use only lifting equipment with sufficient load-bearing capacity.
- Lifting gear must be attached only to positions that have been designated for this purpose.
- Attachments, piping, or cable conduits must never be used to affix lifting gear.
- Unpackaged parts should only be lifted with ropes or straps.
- Attach transportation equipment only to positions intended for this purpose.
- Lifting and securing equipment must conform to the provisions contained in accident prevention regulations.
- Consider the weight of the furnace when choosing lifting and securing equipment. (see Specifications)
- Stainless steel parts (including mounting elements) must always be kept separate from unalloyed steel parts.
- Do not remove corrosion protection until immediately prior to assembly.



### Risks during Normal Operation!

Suspended loads are dangerous. Working beneath a suspended load is prohibited. There is a risk of fatal injury.



### Note

Safety and accident prevention guidelines applicable for forklift trucks must be followed.

### Transportation with a Pallet Truck

Observe the maximum permitted capacity of the pallet truck.

1. Our furnaces are delivered ex works on wooden frames to facilitate unloading. Transport the furnace in its original packaging and with suitable equipment to prevent any damage. Remove the packaging only when the furnace is in its final location. When transporting the furnace, make sure it is secured against sliding, toppling over, and damage. The furnace should be transported and installed by at least two persons. **Do not store the furnace in damp rooms or outdoors.**
2. Push the pallet truck underneath the transportation frame. Make sure that the pallet truck is **completely** beneath the frame. Pay attention to neighboring goods.

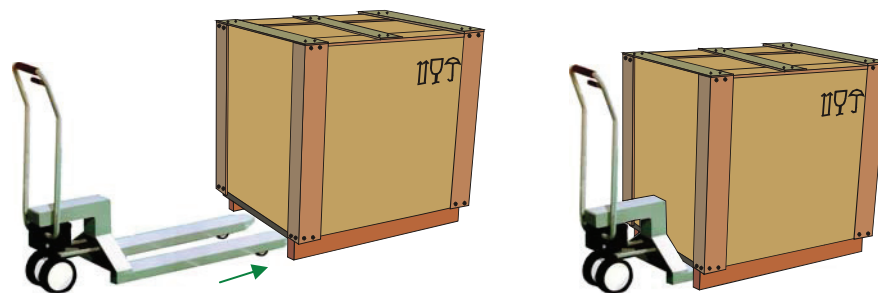





Fig. 5: Pallet truck is pushed **completely** beneath the transportation frame

3. Lift the furnace carefully and pay attention to its center of gravity. When the furnace is being lifted, make sure that the ends of the forks or the load do not catch on neighboring goods.
4. Make sure that the furnace is balanced safely; if not, attach securing equipment. Push the furnace carefully, slowly and with the pallet truck at its lowest position. Do not transport the furnace on inclines.
5. Carefully lower the furnace at its final position. Pay attention to neighboring goods. Try not to set it down too abruptly.

### Symbols:

The international standard symbols for handling packaging are defined in ISO R/780 (International Organization for Standardization) and in DIN 55 402 (German Institute for Standardization).

Description	Symbol	Explanation
Fragile		This symbol is to be attached to fragile goods. Goods marked like this are to be handled carefully and must not be thrown or tied up.
This side up		The freight must be transported, transshipped, and stored in such a way that the arrows point upward. The freight must not be rolled, folded, or stored on edge. However, the package does not have to be packed on top of other freight.
Keep dry		Products with this symbol must be protected against high air moisture, hence, they must be stored under cover. If particularly heavy or bulky packages cannot be stored in halls or sheds, they must be covered carefully with a tarpaulin or similar.
Sling here		The symbol shows only where the sling should be attached, not the method of slinging. If the symbols are at an equal distance from the middle or center of gravity of the package, the package hangs straight if the slings are the same length. If this is not the case, the sling on one side has to be shortened.

## 4.2 Unpacking



### Note

The furnace packaging prevents damage during transportation. Make sure that you remove all packaging material (also inside the furnace chamber). Keep the packaging and transportation securing equipment in case it is needed for future transportation or storage.

At least two people are needed to carry/transport the furnace, more for larger furnaces.



Wear protective gloves

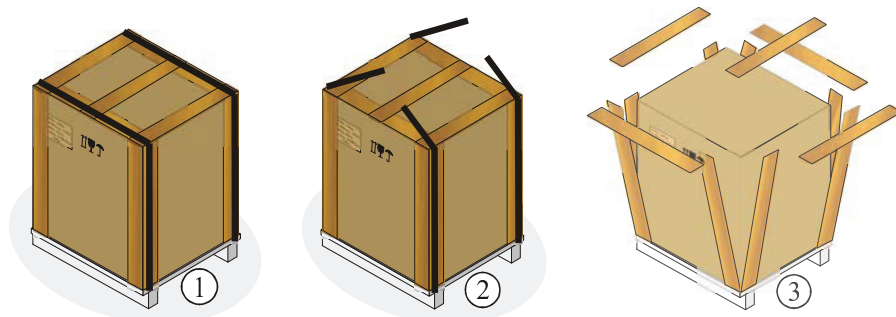

1. Check the transportation packaging for possible damage.
2. Remove tensioning straps from the transportation packaging.
3. Slacken screws and remove wooden casing from the covering box (if available).

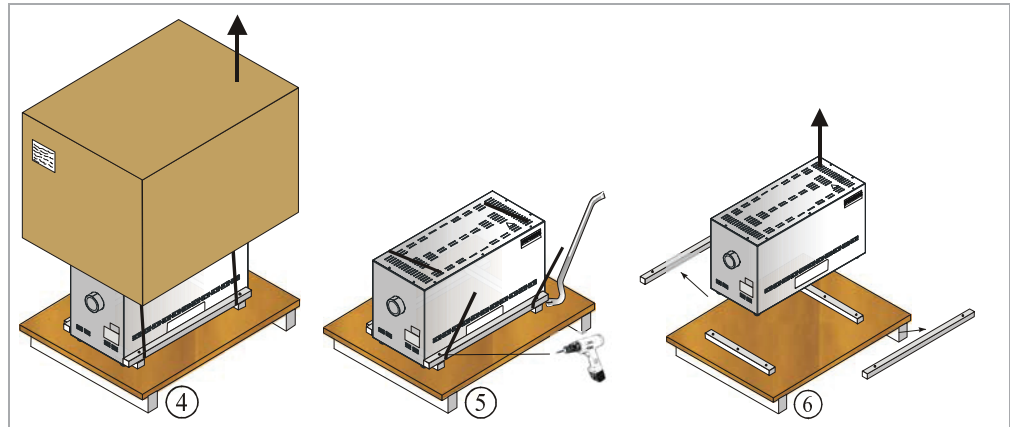

4. Carefully raise the covering box and remove from the pallet.
5. A flat box containing the accessories for your furnace (ceramic insert plate, heating element pliers or optionally a cable) is located on the rear wall of the furnace. Compare the scope of delivery with the delivery note and the order documents, see section on "Delivery". Loosen screws or nails from the retaining strips and remove.
6. Remove retaining strips from the pallet.

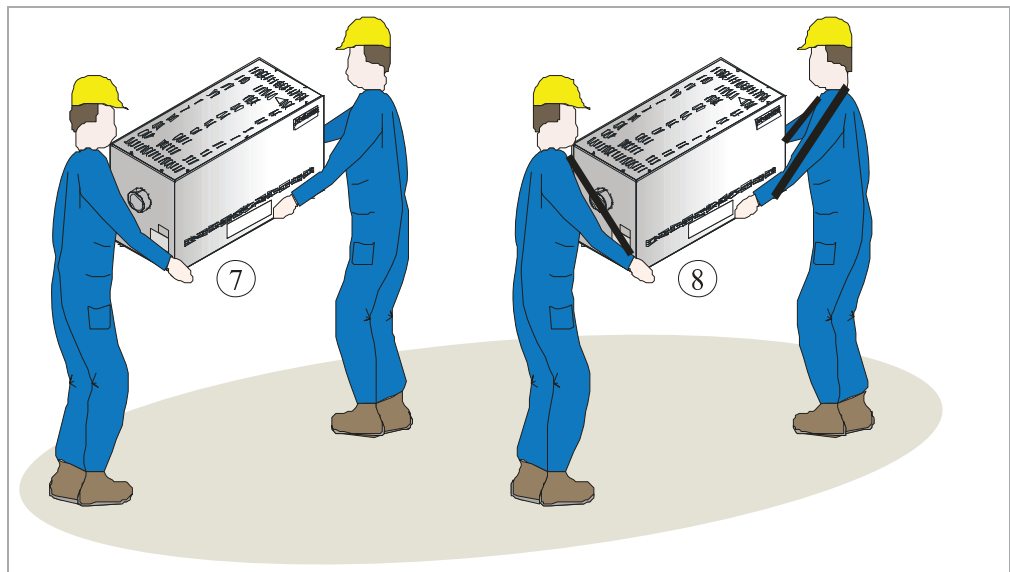

7. Hold the furnace securely by the bottom sides to carry it.
8. For furnaces weighing more than 25 kg, transport work must be carried out by at least 2 people. If transport straps are used, they must be attached crosswise only. Ensure that they are secure.



**Note**

In Germany, the general accident prevent regulations VBG and BGZ must be observed. The national accident prevention regulations of the country of operation apply.



**Note**

Please keep the packaging for possible shipping or storing of the furnace.

### 4.3 Transportation Securing Equipment/Packaging



**Note**

No **special** transportation securing equipment is available for this furnace

The furnace packaging prevents damage during transportation. Make sure that you remove all packaging material (also inside the furnace chamber). All packaging material can be recycled. The packaging was designed so that no special description is necessary.



**Caution - damage to components!**

Ceramic tubes are extremely heat-resistant, but easily breakable – therefore handle with care.

### 4.4 Constructional and Connection Requirements

#### 4.4.1 Installation (Furnace Location)

When the furnace is being set up, the following safety instructions must be followed.

- The furnace must be set up in a dry room in accordance with the safety instructions.
- The table/installation surface must be flat to enable the furnace to be installed levelly. The furnace must be placed on a **nonflammable** surface (stone, metal, or similar).
- The load-bearing capacity of the table must be designed to match the weight of the furnace and the accessories.
- The floor covering must be made of nonflammable material so that hot material falling out of the furnace will not cause the floor covering to ignite.

Although the furnace is well-insulated, the exterior surfaces of the furnace radiate heat. If necessary, this heat must be dissipated (**a ventilation technician may need to be consulted**). In addition, a minimum clearance (S) of 0.5 m on all sides and 1 m above the furnace must be maintained to flammable materials. In individual cases, more space must be chosen in order to match the local conditions. For **nonflammable materials**, the minimum **side** clearance can be reduced to 0.2 m.

If gases and vapors escape from the load, adequate aeration and ventilation at the installation location or a suitable exhaust gas discharge system must be provided. A suitable vent for the combustion exhaust air must be provided by the customer.

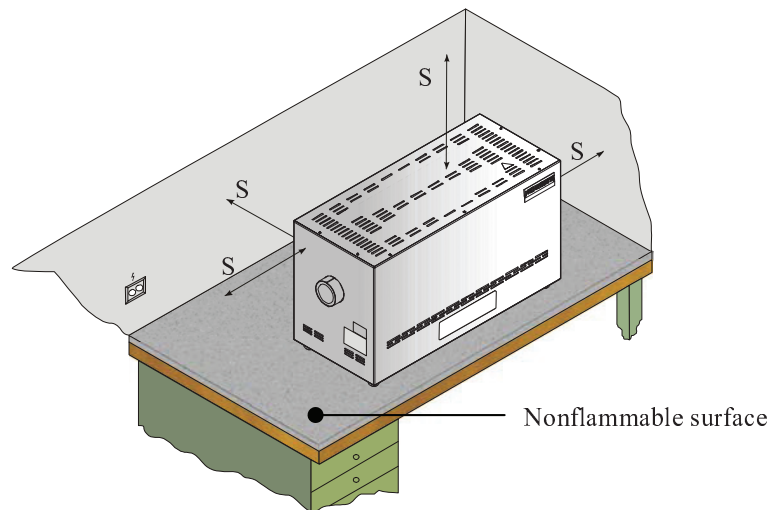

Fig. 6: Installation of a Tube Furnace



**Warning**

Ensure adequate ventilation at the installation location to discharge the heat given off and any exhaust gas formed. Failure to do so will cause a fire and health hazard.



**Note**

Before starting the furnace for the first time, allow it to acclimatize at its installation location for 24 hours.

## 4.5 Assembly, Installation, and Connection

### 4.5.1 Venting Exhaust Fumes

We recommend placing the furnace system underneath a suction system in order to discharge the exhaust gases accordingly.

A commercially available metal exhaust gas pipe may be used as the discharge pipe. It must be laid so that it always slopes upwards and must be fastened to the wall or ceiling.

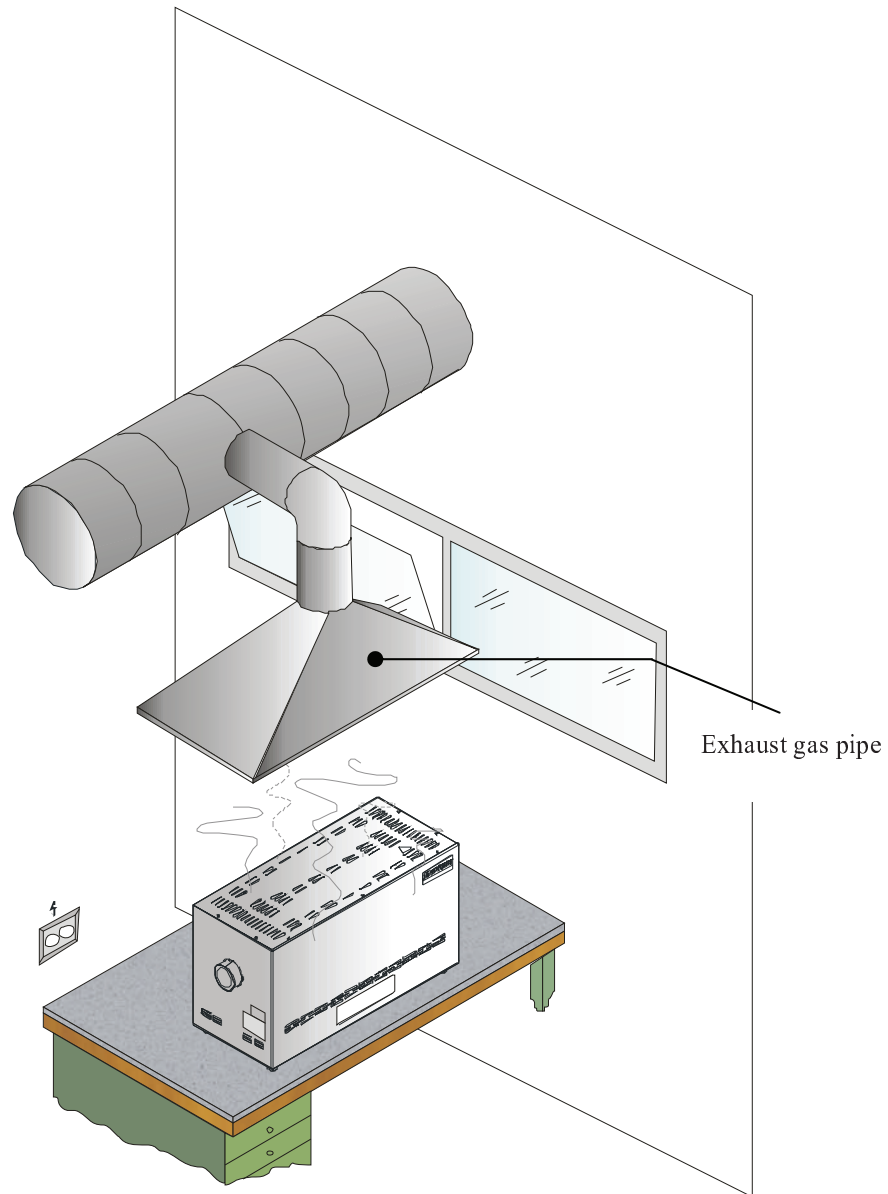

Fig. 7: Assembly of a vent system (example)



**Note**

The exhaust gases can only be discharged if the room is aerated via an appropriate supply air opening.



**Note**

Roof work and/or masonry by the customer is required for the exhaust gas discharge. The size and design of the exhaust gas discharge must be determined by a ventilation technician. The national regulations of the local country apply.

## 4.5.2 Connecting the Furnace to the Power Supply

Requirements such as the load capacity of the installation surface, provision of power (electricity), etc. must be fulfilled on-site by customer.

- The furnace must be installed in accordance with the designated use. The AC power connection must match the values given on the rating plate on the furnace.
- The power outlet must be close to the furnace and must be easily accessible. The safety requirements are not fulfilled if the furnace is not connected to an outlet with a ground contact.
- If an extension cable or a power bar is used, its maximum electrical load capacity must not be exceeded. Do not use an extension cable with the furnace if you are not sure if this will guarantee grounding or not.
- The power cable must not be damaged. Do not place any objects on the power cable. Lay cables so that nobody can step on or trip over them.
- A power cord may be replaced only by an approved equivalent type of cord.
- Ensure that the furnace connection line is laid in a protected manner.



**Note**

Before connecting the power supply, ensure that the power switch is set to the "Off" or "0" position.

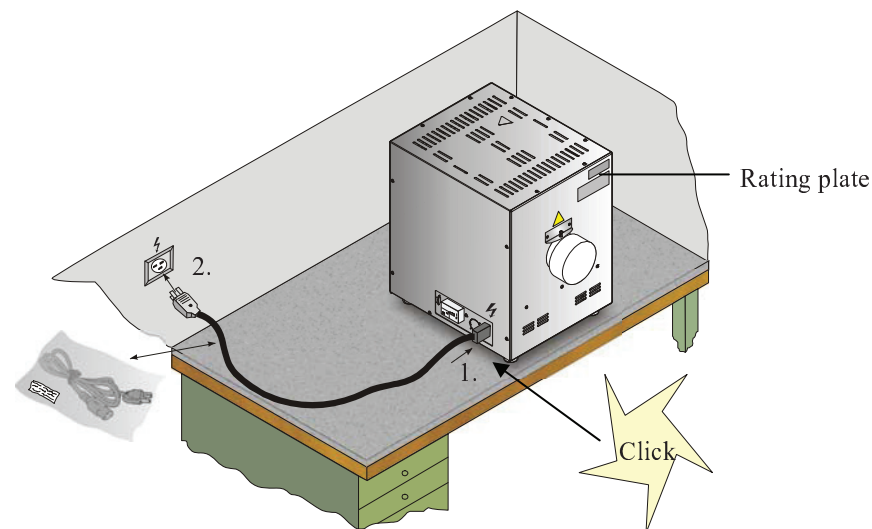

Fig. 8: Furnace up to 3.6 kW (power cable included with delivery)

1. First plug the supplied power cable into the socket provided for this purpose on the furnace.
2. Now plug the supplied power cable into the AC power supply. Only use a power outlet with a ground contact.



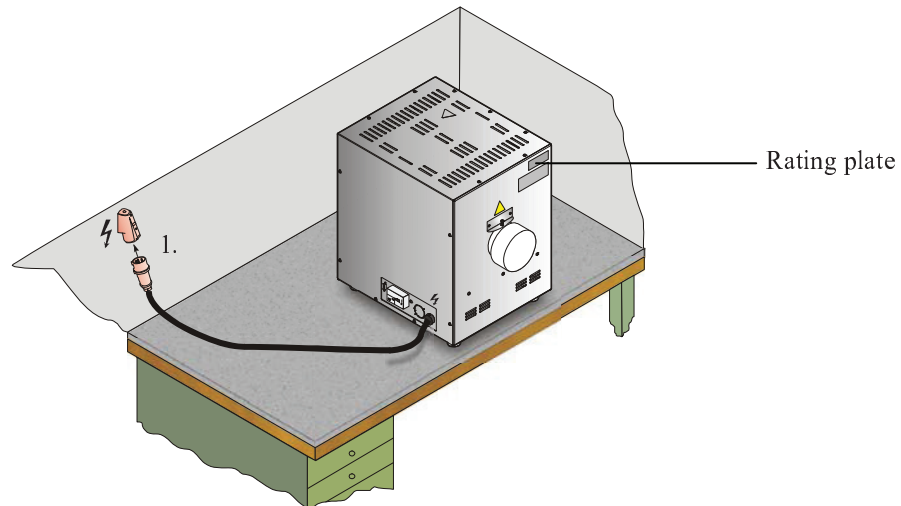

Fig. 9: Furnace 4.4 kW to 6.5 kW

1. Connect the power cable to the power connection. Only use a socket with grounding contact to supply power.

Grounding of the furnace and switching system (compliant with VDE 0100, part 410) is a prerequisite for the current-operated e.l.c.b. system of the heater.

Test the ground resistance (in accordance with VDE 0100); see also accident prevention regulations.

Electrical systems and equipment in accordance with BGV A3.



**Note**

For wiring and electrical connections, see the attached circuit diagram. The electrical equipment of the machine can also be seen in the circuit diagram.



**Note**

The national regulations of the respective country of operation apply.



**Warning! Electrical hazard!**

Work on the electrical equipment may only be performed by qualified, authorized electricians.

### 4.5.3 Inserting/Introducing the Working Tube



**Warning! Electrical hazard!**

Before inserting or introducing the working tube, ensure that the power switch is set to the "Off" or "0" position.



**Warning! Electrical hazard!**

The furnace must not be put into operation without the working tube/protective caps. Otherwise there is a risk of electric shock.



**Caution - damage to components!**

Ceramic tubes are extremely heat-resistant, but easily breakable – therefore handle with care.

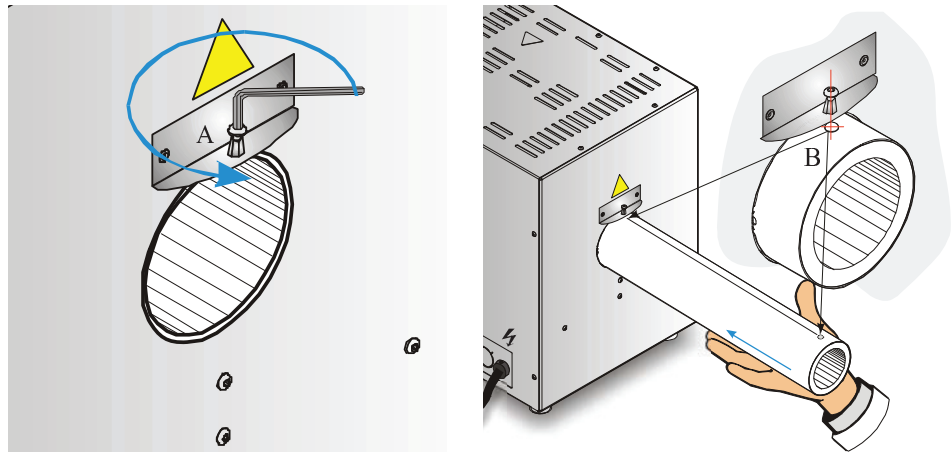

Fig. 10: Inserting the working tube

Loosen the safety screw (A) from the retaining plate using the provided Allen wrench. After fully unpacking the working tube, cautiously slide the working tube into the provided opening. The through-hole of the working tube must match up with the safety screw (B). Make sure that no packaging material remains in the working tube.

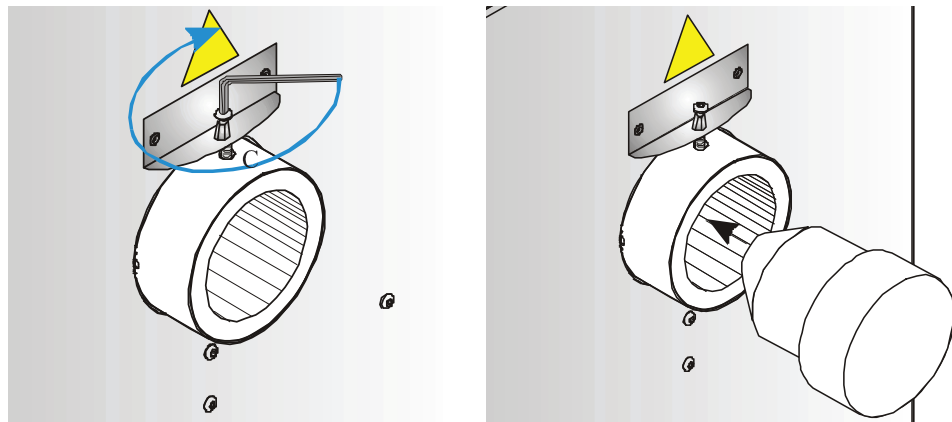

Fig. 11: Locking the working tube

To avoid accidentally pushing out the working tube, cautiously screw in the previously loosened safety screw until the screw thread (C) has sunk into the through-hole of the working tube. Close the tube ends with the provided fiber plugs.

**Note**

If the furnace is supplied without the working tube at the customer's request, the openings must be secured by protective caps at the factory. Removal of these protective devices and operating the furnace without working tube voids the conformity.

## 4.6 Commissioning

Commissioning of the system may only be performed by qualified personnel observing the safety instructions.

Read the section "Safety" as well. When commissioning the system, the following safety instructions must absolutely be followed - this will avoid life-threatening injury to personnel, system damage, and other property damage.

Make sure that the instructions and notes in the controller instructions are observed and followed.

The system may only be used according to its intended purpose.

Make sure that only authorized personnel are located in the working area of the machine and that no other person is at risk due to the startup of the system.

Before the first start, check whether all tools, external parts, and transportation locks have been removed from the system.

Activate all safety systems (power switch, EMERGENCY STOP button if available) before commissioning.

Incorrectly wired connections can destroy electrical/electronic components.

Follow the special safety measures (e.g. grounding, etc.) for the components at risk.

Incorrect connections can cause unexpected startup of the system.

Inform yourself before starting the system about the proper behavior in case of malfunction and in case of emergency.

Before the first startup, check the electrical connections and control displays.

**Note**

Before starting the furnace for the first time, allow it to acclimatize at its installation location for 24 hours.

**Note**

The furnace must not be put into operation without the working tube/protective caps. Otherwise there is a risk of electric shock.

## 4.7 Recommendations for Heating the Furnace for the First Time



To achieve a protective oxide layer on the heating elements, the furnace must be heated to **100°C below the maximum temperature, depending on the employed working tube** and according to the **heating rates** given below. This temperature must be **maintained** for approx. **1 hour**. This process must be carried out on commissioning, after exchanging the heating elements or to regenerate the oxide layer. Odor pollution may occur during heating; this is due to the escape of binder from the insulating material. We recommend ventilating the furnace location well during the first heating phase.

## 4.8 Maximum permissible heating rates



### Warning - General hazards!

When heating the furnace, comply with the following heating rates depending on the working tube, unless otherwise directed.

**Failure to observe this rule will lead to the destruction of the working tube and possibly to the heating elements.**

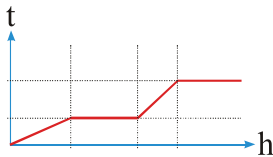

- Working tubes made of **vitreous silica: not required.**
- Working tubes made of **C 530** (Sillimantin) or **APM** (CrFeAl alloy) with an outside diameter < 120 mm: **not required.**
- Working tubes made of **C 610** (Pythagoras), **C 799** (Alsint) with an outside diameter < 120 mm: **300°C/h.**
- All working tubes with outside diameter **from 120 mm: 200°C/h.**

### Cracks in the insulation

The insulation of the furnace consists of a very high-quality refractory material. Heat expansion may cause cracks in the insulation even after a few heating cycles. However, these have no effect on the functioning or quality of the furnace.

## 5 Operation

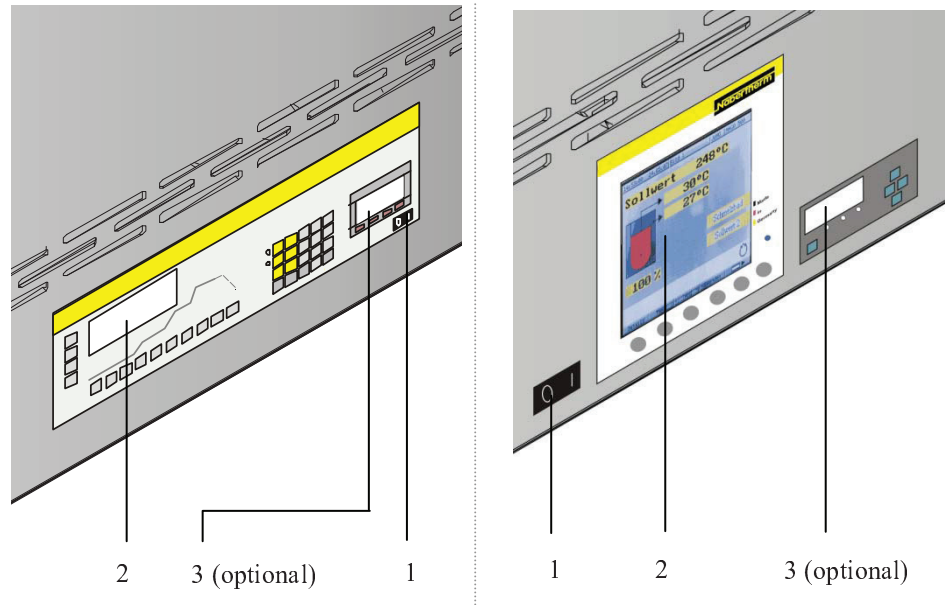
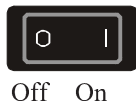

Fig. 12: Furnace system with controller



1. The control current is turned on and off via the power switch (1). When the control current is switched on, the heating chamber temperature is indicated in the LED display on the controller (2).
2. The desired heating and cooling program is set on the controller (2). Please see the separate manual for a description of the controller.
3. The temperature of the over-temperature limit controller (3) (optional) must be set 30°C higher than that of the controller. Please see the separate manual for a description of the over-temperature limit controller.



### Note

Continuous operation at the maximum temperature can lead to accelerated wear of the heating elements and the insulation. We recommend working at approx. **50°C below the maximum temperature**.

### 5.1 Maximum permissible heating rates



#### Warning - General hazards!

When heating the furnace, comply with the following heating rates depending on the working tube, unless otherwise directed.

**Failure to observe this rule will lead to the destruction of the working tube and possibly to the heating elements.**

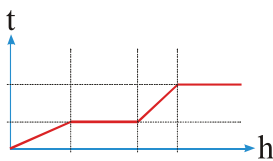

- Working tubes made of **vitreous silica: not required**.
- Working tubes made of **C 530** (Sillimantin) or **APM** (CrFeAl alloy) with an outside diameter < 120 mm: **not required**.
- Working tubes made of **C 610** (Pythagoras), **C 799** (Alsint) with an outside diameter < 120 mm: **300°C/h**.
- All working tubes with outside diameter **from 120 mm: 200°C/h**.

## 5.2 Loading/Charging

### Charging the Furnace

Only materials whose characteristics and melting temperatures are known may be heated. Consult any available safety-related material data sheets.

The furnace must also be charged when cold.

When charging the furnace make sure that the working tube is not damaged.

The charging must be in as small quantities as possible positioned in the center of the charge space of the working tube. This ensures uniform heating.

When a very large quantity of ware is loaded into the working tube the warm-up times can be substantially longer.

The removal of the fiber plugs, flanges and protective lid is prohibited when hot ( $> 400\text{ }^{\circ}\text{C}$ ). The resulting thermal shock leads to the destruction of the working tube and, possibly, of the heating elements.

Personnel must wear the appropriate protective clothing, and the workspace must be adequately ventilated as stated in the section entitled "Safety".

Stainless steel sheet can discolor (especially if the furnace is opened while hot), but this does not impair the functionality of the furnace.

### Additional precautionary measures

Please make sure that objects such as teapots and bottles are kept away from the furnace.



#### Warning - Danger of Electric Shock!

For the protection of the operator and the furnace the heating program must be stopped before the furnace is loaded. Ignoring this warning can result in electric shock.



#### Caution - damage to components!

Ceramic tubes are extremely heat-resistant, but easily breakable – therefore handle with care.

## 6 Servicing, Cleaning, and Maintenance



#### Warning! General hazards!

Cleaning, lubrication, and maintenance tasks may only be performed by authorized experts following the maintenance instructions and accident protection guidelines. We recommend that maintenance and repair be performed by Nabertherm GmbH Service. Failure to comply runs the risk of bodily injury, death, or significant property damage!



#### Warning - danger due to electrical current!

Work on the electrical equipment may only be performed by qualified, authorized electricians!

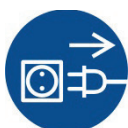

During maintenance work, the voltage supply to the furnace and/or switching system must be switched off to prevent unintentional commissioning. Disconnect the mains power connector due to reasons of safety.

Operators may only correct malfunctions which are obviously due to operational error! Wait until the furnace chamber and attaching parts have cooled to room temperature.

The furnace must be visually inspected at regular intervals for damage. The interior of the furnace must also be cleaned as required (e.g. vacuuming out) **Attention:** Do not bang against the heating elements to avoid breaking them.

While work is being performed on the furnace, the furnace and work room must additionally be ventilated with fresh air.

Safety systems removed during maintenance tasks must be replaced after the work.

Warning of swinging loads in the workshop (e.g. crane systems). Work under a lifted load (e.g. a lifted furnace or switching system) is not permitted.

Safety switches and any limit switches present must be checked for function periodically (BGV A3) or according to the national guidelines of the country of operation.

To ensure proper temperature regulation of the furnace, the thermocouple must be checked for damage before every process.

If necessary, retighten the element holders (see chapter "Replacing the Heating Element"). Before carrying out this work, the voltage supply to the furnace and/or switching system must be switched off (disconnect mains power connector). The regulations (BGV A3) or corresponding national regulations in the relevant country of operation must be observed.

There are one or more contactors in the control system. The contacts of these circuit breakers are wearing parts and must therefore be serviced and/or replaced regularly (BGV A3) or according to the national guidelines of the country of operation.

The switching system cabinet (if available) contains vent grilles with integrated filter mats. These must be cleaned and/or replaced at regular intervals in order to ensure sufficient intake and outflow of air from the switching system. During melting operation, the switching cabinet door must always be firmly closed.



#### **This furnace contains ceramic fiber material in the insulation.**

Active handling of these fibers (e.g., exchange of the insulation) in the Federal Republic of Germany is subject to the conditions of the Ordinance on Hazardous Substances, Annex V, No. 7 ("Artificial mineral fibers") of June 12, 1998. In the rest of the European Union, ceramic fibers are categorized as follows by Directive 97/69/EC of the Commission of December 5, 1997 CARC. Cat. 2; R 49; Xi R 38. Work with the fiber insulation must therefore be done in such a way that as little fiber dust as possible is released.

#### **The following points must be noted when handling ceramic fiber:**



- Dust development during processing should be minimized.
- Contact with skin and eyes should be avoided. The effects caused by fibers on the skin or in the eyes may cause mechanical irritation, as a result of which reddening and itching may occur.
- When processing large quantities of ceramic fibers, loose work clothing with long sleeves, gloves and safety glasses should be worn.
- When working with ceramic fiber insulation inside furnaces, a half/quarter mask with P2 filter should additionally be worn.

The furnace and its operating equipment must be regularly checked in accordance with the regulations of the employer's liability insurance association (BGV A3) or the corresponding national regulations in the relevant country of use!

## 6.1 Shutting the System Down for Maintenance



### Warning! General Hazards!

Cleaning, lubrication, and maintenance tasks may only be performed by authorized experts following the maintenance instructions and accident protection guidelines. We recommend that maintenance and repair be performed by Nabertherm GmbH Service. Failure to comply runs the risk of bodily injury, death, or significant property damage!

**Wait until the furnace chamber and attached parts have cooled to room temperature.**

- The furnace must be completely emptied
- Inform operating personnel and name supervisors
- Switch off main switch and/or disconnect the power cord.
- Lock the main switch and secure against restoration of power using a padlock.
- Attach a warning sign on the main switch
- Clean up the maintenance area as far as possible.
- Check for disconnection of power.
- Ground and short-circuit the working area.
- Cover any nearby parts still under power.



### Warning - Dangers During Normal Operation!

Do not touch any object without first having checked its temperature.



### Warning - Danger of Electric Shock!

Work on the electrical equipment may be done only by qualified, authorized electricians. During work it must be ensured that the furnace and the switching equipment cannot be activated by mistake (pull out the power plug) and that all moving parts in the furnace are secured. Observe BGV A3 or the corresponding national regulations in the country where the furnace is installed. Wait until the furnace and the connected parts have cooled to room temperature.





## 6.2 Regular Maintenance of the Furnace

Item/ maintenance point	Action	Maintenance Interval					Operati ng	Qualifi ed
		Day	Week	Month	Quarte r	Year	Personnel	
Safety test in accordance with BGV A3 or corresponding national regulations	According to regulations					●		X
EMERGENCY STOP device	Press the button or power switch	●					X	
Drives and 3rd-party subassemblies (if present)	Maintain according to manufacturers' instructions. Visual inspection.							X
Safety and limit switches (if present)	Perform functional test					●		X
Furnace chamber, exhaust holes and pipes	Clean and check for damage; vacuum out carefully	●					X	
Sealing surfaces: Door collar	Visual inspection	●					X	
Seals (if present)	Clean/replace		●				X	
Heating elements	Visual inspection		●					X
Working tube, fiber plugs and flanges	Visual inspection, E.g. check for cracks	● ■				●		X
Check for uniform power consumption by heating system	Functional test					●	X	
Thermocouple	Visual check of display at the controller				●		X	
Check settings	Check according to work schedules	●					X	
Settings at the over-temperature limit controller (if present)	Each time the heat treatment program is changed	●					X	
Legend:		■ = clean		● = check, replace		x = performed by		

Fig. 13: Maintenance table

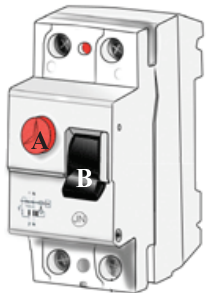
	<p><b>Note</b></p> <p>Ground fault circuit interrupters (earth leakage circuit breakers) installed on the rear side (see section on "Overall View of the System") are equipped with a test button (A) for carrying out a simple function test. The test button should be operated for checking every 4 weeks. The test is successful if the switch (B) jumps to "0" when the test button is pressed. Following the successful test, set the switch back to "I". If the switch does not jump to "0", have the defective ground fault circuit interrupter replaced by a qualified electrician and checked by means of a measuring device. The system must not be put in operation without a functioning ground fault circuit interrupter. For performing the test the furnace system must be switched on.</p>
<p>Example</p>	

**Note**

If used, over-temperature limiters with manual or automatic reset (see “overview of the furnace”) must be checked regularly to ensure that they function as intended. To check whether the over-temperature limiters respond, start the furnace and set the required set point on the temperature control unit below the set point of the controller. For more information, see the operating instructions for over-temperature limiter with automatic reset/over-temperature limiter with manual reset.

**Note**

Operating furnaces with heating transformers can trigger an upstream fault-current circuit breaker due to the EMC filter circuitry. For this reason, fault-current circuit breakers should not be used as protection switchgear.

**Warning - Danger of Electric Shock!**

Work on the electrical equipment may be done only by qualified, authorized electricians.

**Note**

Maintenance work must be performed by authorized personnel following the maintenance instructions and the accident prevention regulations. We recommend that the maintenance and repair work be carried out by the service team of Nabertherm GmbH.

### 6.3 Operating and Auxiliary Materials

### 6.4 Cleaning Products



Follow the procedure for shutting down the furnace system (in the "Operation" section). Then the power plug must be pulled out of the socket. Wait until the furnace cools down naturally.

Use commercially available detergent which is either water-based or non-combustible and free of any solvents to clean the housing of any deposits; use a vacuum cleaner for the interior.

**Follow the labeling and the instructions on the packaging of the detergent.**

Wipe the surface with a damp, lint-free cloth. The following detergents can also be used:

This list must be completed by the operator.	
Component and location	Detergent
Outer surfaces (frames *)	Use commercially available detergent which is either water-or non-combustible and free of any solvents for cleaning *)
Outer surface (stainless steel)	Stainless still cleaner
Interior	Carefully clean with a vacuum cleaner (avoid the heating elements)
Insulation materials	Carefully clean with a vacuum cleaner (avoid the heating elements)
Door seal (if included)	Use commercially available detergent which is either water-or non-combustible and free of any solvents for cleaning
Instrument panel	Wipe the surface with a damp, lint-free cloth. (e.g. glass cleaner)
*) You must be sure that the cleaner does not damage the water-soluble and, hence, environmentally safe paint (the clear should be tried first on an interior, normally unseen location).	

Fig. 14: Detergent

Do the cleaning from beginning to end without breaks to protect the surfaces.

Remove the detergent completely from the surfaces by wiping them with a damp, lint-free cloth.

After cleaning all the supply lines, check all the connections for leaks, loose connections, abrasion and damage; report any shortcomings found immediately!

**Please follow the section entitled "Environmental Protection Rules and Regulations"**



**Caution**

The furnace, the furnace chamber and attached components must **NOT** be cleaned using a high-pressure cleaner.

## 7 Malfunctions

Work on the electrical system may be done only by qualified, authorized electricians. Operators may only rectify malfunctions that are obviously due to operating errors. Call the local electrician for malfunctions that you cannot localize.

If you have any questions, problems, or requirements, contact Nabertherm GmbH. By mail, phone, or e-mail → See "Nabertherm Service".

Type of malfunction	Possible causes	Correcting the malfunction
Controller does not switch on.	<ul style="list-style-type: none"> <li>-No voltage available.</li> <li>-Controller defective.</li> </ul>	<ul style="list-style-type: none"> <li>-Check connection fuse(s), renew if necessary.</li> <li>-Check controller fuses (if available), renew if necessary.</li> <li>-Check plug connector.</li> <li>-Have checking carried out by Nabertherm Service.</li> </ul>
Controller indicates malfunction.	<ul style="list-style-type: none"> <li>-See separate instructions for controller.</li> </ul>	<ul style="list-style-type: none"> <li>-See separate instructions for controller.</li> </ul>
No heating chamber heating after starting program.	<ul style="list-style-type: none"> <li>-Error in program input.</li> <li>-Connection fuse(s) defective.</li> <li>-Heating element defective</li> </ul>	<ul style="list-style-type: none"> <li>-Check heating program (see separate instructions for controller)</li> <li>-Check connection fuse(s), renew if necessary. Notify Nabertherm Service if the new fuse trips on screwing in.</li> <li>-Have checking carried out by Nabertherm Service.</li> </ul>
Very slow heating of the heating chamber	<ul style="list-style-type: none"> <li>-Connection fuse(s) defective.</li> </ul>	<ul style="list-style-type: none"> <li>-Check connection fuse(s), renew if necessary. Notify Nabertherm Service if the new fuse trips on screwing in.</li> </ul>
Selected end temperature not reached.	<ul style="list-style-type: none"> <li>-Lack of heater output due to undervoltage.</li> <li>-Heating element defective</li> <li>-Ends of the working tube not closed (fiber plugs, vacuum flanges)</li> </ul>	<ul style="list-style-type: none"> <li>-Have checking carried out by Nabertherm Service.</li> <li>-Close ends of the working tube (fiber plugs, vacuum flanges)</li> </ul>

## 8 Spare Parts/Wearing Parts



### Ordering Spare Parts:

Our Nabertherm Service team is available to you all around the world. Due to our considerable production depth we deliver most spare parts from the warehouse overnight or can make them ready for delivery within short deadlines. You can order Nabertherm spare parts easily and simply directly from the factory. If you cannot find the spare part you want we will be glad to help you. Spare parts can be ordered in writing, by phone or on the Internet -> see the section entitled "Nabertherm Service".

### Availability of Spare Parts and Wearing Parts:

Although Nabertherm has many spare parts and wearing parts on stock, we cannot guaranty the short-term availability of all of them. We recommend that certain parts be ordered in advance. If you need any assistance when selecting spare parts and wearing parts, the staff at Nabertherm will be glad to set aside time for you.



#### Note

Original parts are designed especially for Nabertherm furnaces. Replace parts only with original Nabertherm parts. Otherwise the warranty will be void. Nabertherm accepts absolutely no liability for damage caused by using parts that are not original Nabertherm parts.



#### Note

Contact our Nabertherm Service for removing and installing replacement and wear parts. See section on "Nabertherm Service". Work on the electrical equipment may only be performed by qualified and authorized specialist electricians. This applies also to repairs not described below.

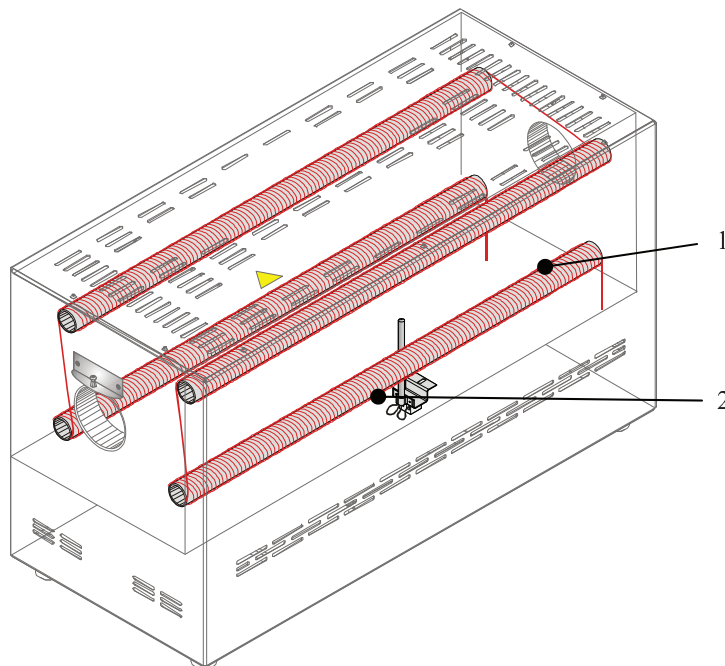

Fig. 15: Sample replacement parts on the Compact Tube Furnace, model R .../.../12

### Heating Coil

No.	Furnace Model	Name	Part Number	Quantity	Included With Replacement Parts Delivery
1	R 50/250/12	Heating coil set	602 210 788	1	-Wire hooks -Connection terminals
	R 50/500/12	Heating coil set	602 210 794	1	
	R 100/750/12	Heating coil set	602 210 798	1	
	R 120/1000/12	Heating coil set	602 211 282	1	

### Thermocouple

No.	Furnace Model	Name	Part Number	Quantity
2	R 50/250/12	Thermocouple Type S, 130 mm installation wire 0.3 mm	540 300 255	1 (2*)
	R 50/500/12 R 100/750/12	Thermocouple Type S, 130 mm installation wire 0.3 mm	540 300 255	1 (2*)
	R 120/1000/12	Thermocouple Type S, 170 mm installation wire 0.3 mm	540 300 256	1 (2*)

\*) Furnaces with over-temperature limit controllers are equipped with 2 thermocouples each

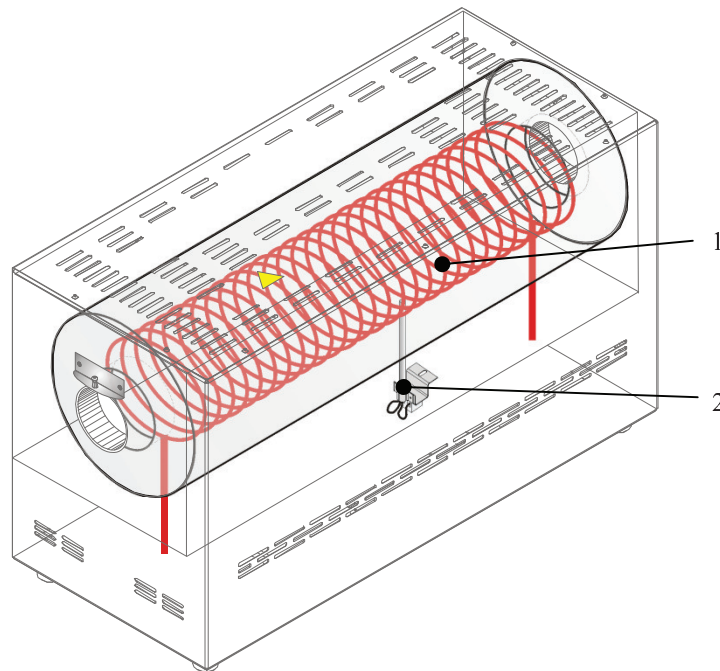

Fig. 16: Sample replacement parts on the Compact Tube Furnace, model R .../.../13

### Heating Module

No.	Furnace Model	Name	Part Number	Quantity	Included With Replacement Parts Delivery
1	R 50/250/13	Heating module set	692 250 646	1	
	R 50/500/13	Heating module set	692 250 647	1	



	R 100/750/13	Heating module set	692 270 068	1	
	R 120/1000/13	Heating module set	692 270 070	1	

### Thermocouple

No.	Furnace Model	Name	Part Number	Quantity
2	R 50/250/13	Thermocouple Type S, 140 mm installation wire 0.3 mm	540 300 259	1 (2*)
	R 50/500/13 R 100/750/13	Thermocouple Type S, 140 mm installation wire 0.3 mm	540 300 259	1 (2*)
	R 120/1000/13	Thermocouple Type S, 170 mm installation wire 0.3 mm	540 300 256	1 (2*)

\*) Furnaces with over-temperature limit controllers are equipped with 2 thermocouples each



### Other Replacement Parts

No.	Name	Part Number	R 50/250/12	R 50/500/12	R 100/750/12	R 120/1000/12	Comment
			Quantity				
3	-Ground fault circuit interrupter -Fiber plug -Support tubes	*)	1	1	1	1	  
4			MnB	MnB	MnB	MnB	
5							
6							
7							
8							
9			MnB	MnB	MnB	MnB	

\*) = Spare part supply depending on version

MnB = Quantity as required

### Other Replacement Parts

No.	Name	Part Number	R 50/250/13	R 50/500/13	R 100/750/13	R 120/1000/13	Comment
			Quantity				
3	-Ground fault circuit interrupter -Fiber plug	*)	1	1	1	1	 
4			MnB	MnB	MnB	MnB	
5							
6							
7							
8							
9			MnB	MnB	MnB	MnB	

\*) = Spare part supply depending on version

MnB = Quantity as required



### Ordering Spare Parts:

Our Nabertherm Service team is available to you all around the world. Due to our considerable production depth we deliver most spare parts from the warehouse overnight or can make them ready for delivery within short deadlines. You can order Nabertherm spare parts easily and simply directly from the factory. If you cannot find the spare part you want we will be glad to help you. Spare parts can be ordered in writing, by phone or on the Internet -> see the section entitled "Nabertherm Service".

### Availability of Spare Parts and Wearing Parts:

Although Nabertherm has many spare parts and wearing parts on stock, we cannot guaranty the short-term availability of all of them. We recommend that certain parts be ordered in advance. If you need any assistance when selecting spare parts and wearing parts, the staff at Nabertherm will be glad to set aside time for you.

## 8.1 Repairing the Insulation

The insulation of the furnace consists of a very high-quality refractory material. Heat expansion may cause tears in the insulation even after a few heating cycles. However, these have no affect on the function or quality of the furnace. However, if entire "sections" of the insulation come loose, Nabertherm Service must be notified.

## 9 Accessories (Options)

### 9.1 Laboratory Gas Supply Station



Gas panel (individual panel)  
for simple protective gas applications.

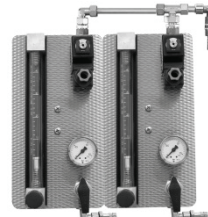

Gas panel (double panel)  
for operating with two non-combustible types of gas.

Fig. 17: Laboratory gassing stations

Gassing station are conceived for commercial applications in laboratories. Nabertherm furnaces can be upgraded with various equipment packages for operation with non-combustible gases. The various equipment packages can be delivered together with the furnace, but also at a later time as well. You can select from gas panels which function just manually or both manually and automatically We provide gas supply systems for non-combustible protective gas (argon Ar, nitrogen  $N_2$  and inert gas  $N_2H_2$  95/5) with shut-off valve, flowmeter and control valve.

### 9.2 Over-temperature Limit Controller

These Nabertherm GmbH furnaces are equipped **as standard** with a over-temperature limiter to protect against over-temperature in the furnace chamber.

The over-temperature limiter with manual reset monitors the temperature in the furnace chamber. The display shows the last trigger temperature that was set. When the furnace chamber temperature exceeds the set triggering temperature, the heating is switched off to protect the furnace or charge.





Fig. 18: Over-temperature limit controller with manual reset 2132i



**Note**

See additional operating instructions for description and function

### 9.3 Available Working Tubes

 Working tube outside Ø x inside Ø x length in mm	Order number	Model R				Comment
		50-250	50-500	100-750	120-1000	
<b>C 530 (Sillimantin)</b>	(part number)					
40 x 30 x 450	692070274	o				
40 x 30 x 700	692070276		o			
50 x 40 x 450	692070275	•				
50 x 40 x 700	692070277		•			
60 x 50 x 1100	692070101			o		
70 x 60 x 1070	692070048			o		
80 x 70 x 1100	692070109			o		
95 x 80 x 1070	692070049			•		
120 x 100 x 1400	692070279				•	

\*) Only working tubes with outside diameters as when the furnace was acquired may be used, since the insulation of the furnace was drilled to this dimension.



**Key**

- Standard working tube.
- o Working tube optionally available.
- 1) For use with water-cooled end flanges.
- 2) With welded flanges for use with water-cooled flange covers.
- 3) Tubes/rectors, incl. attached sleeves for the rotary drive. Replacement tubes without sleeves.

# 10 Electrical Connections (Circuit Diagram)

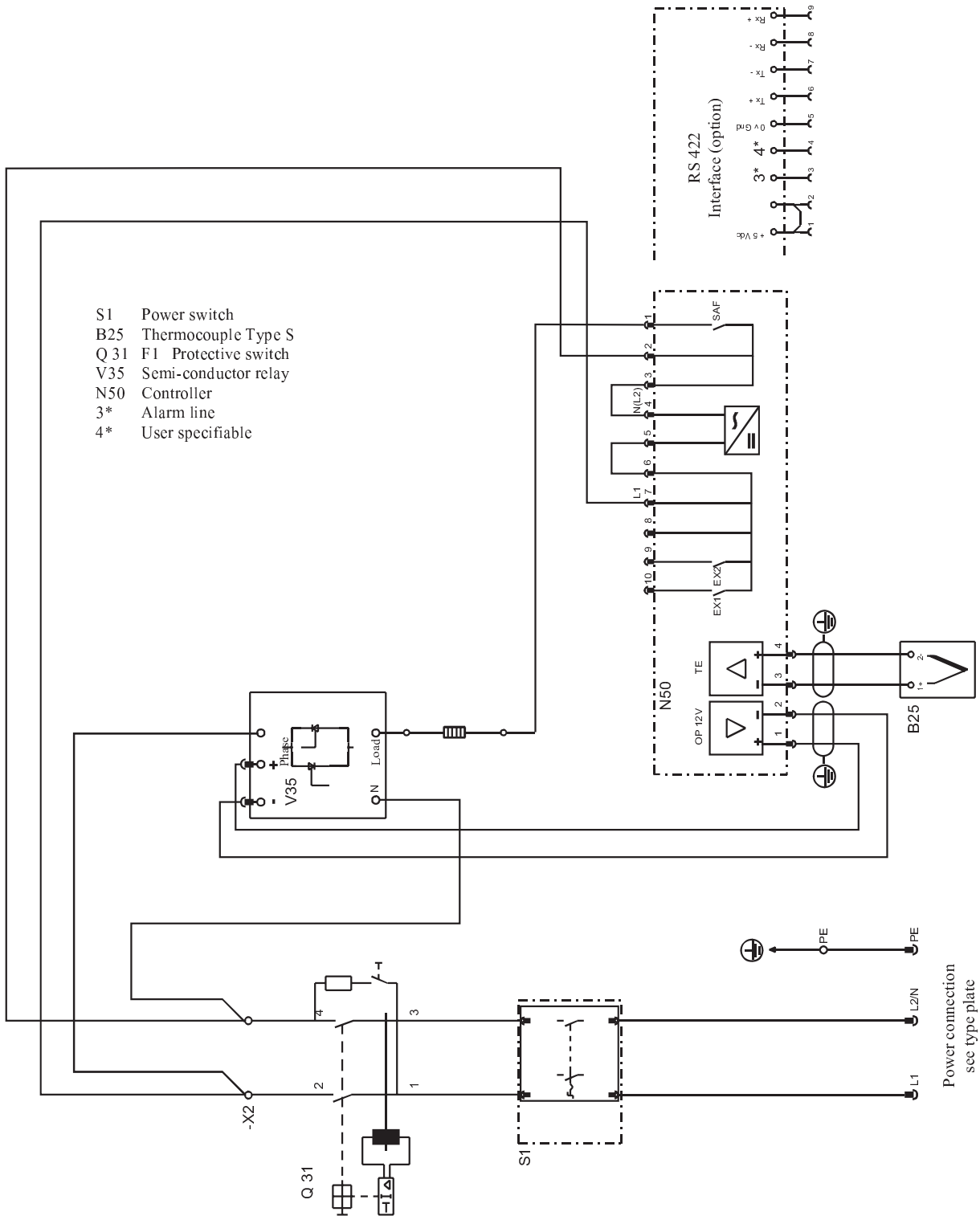

Fig. 19: R .../250-750/12\_200V-240V ~1/N/PE, 2/PE, 50/60Hz

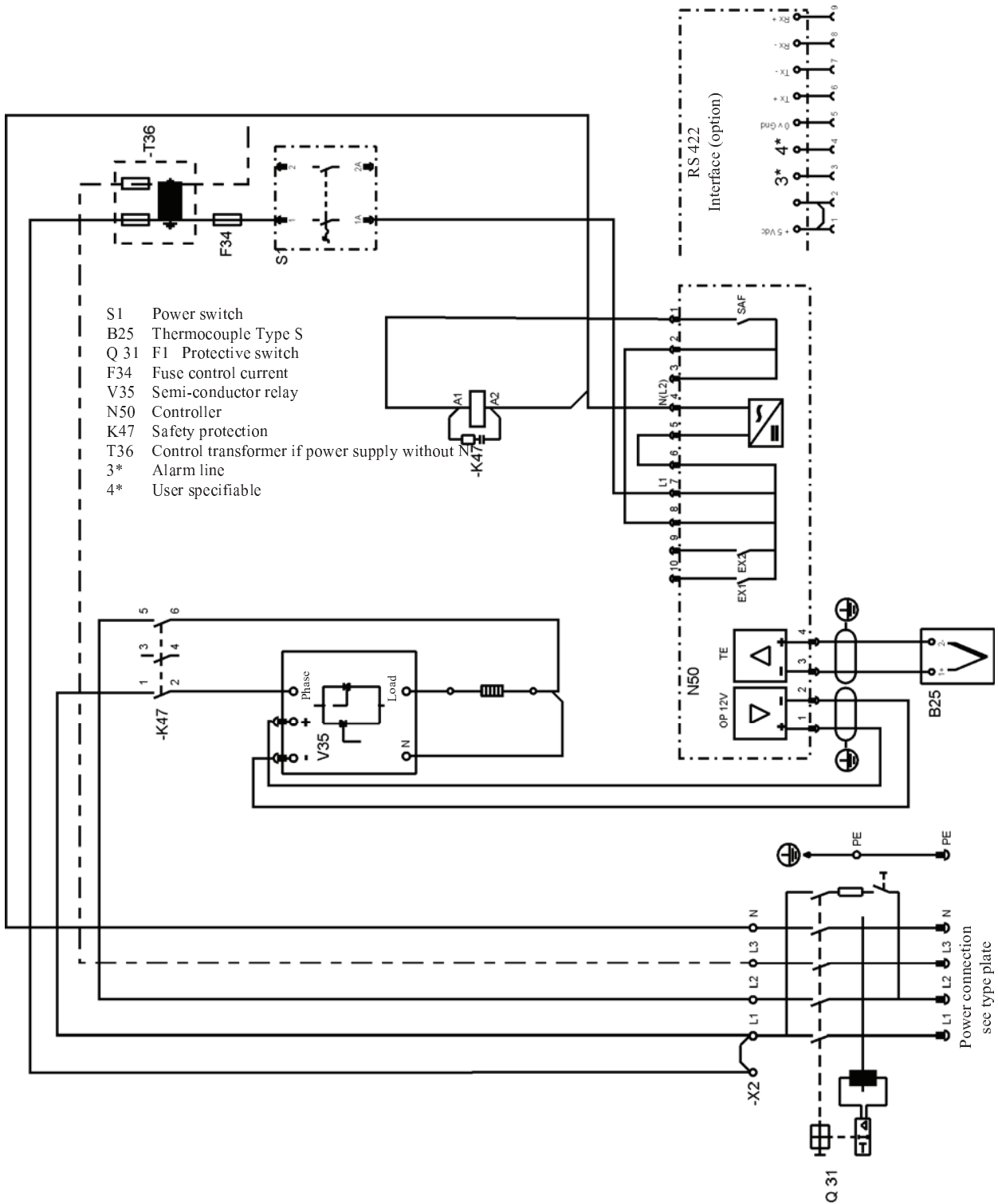

Fig. 20: R .../1000/12\_400V~3/NPE, 3/PE, 50/60Hz

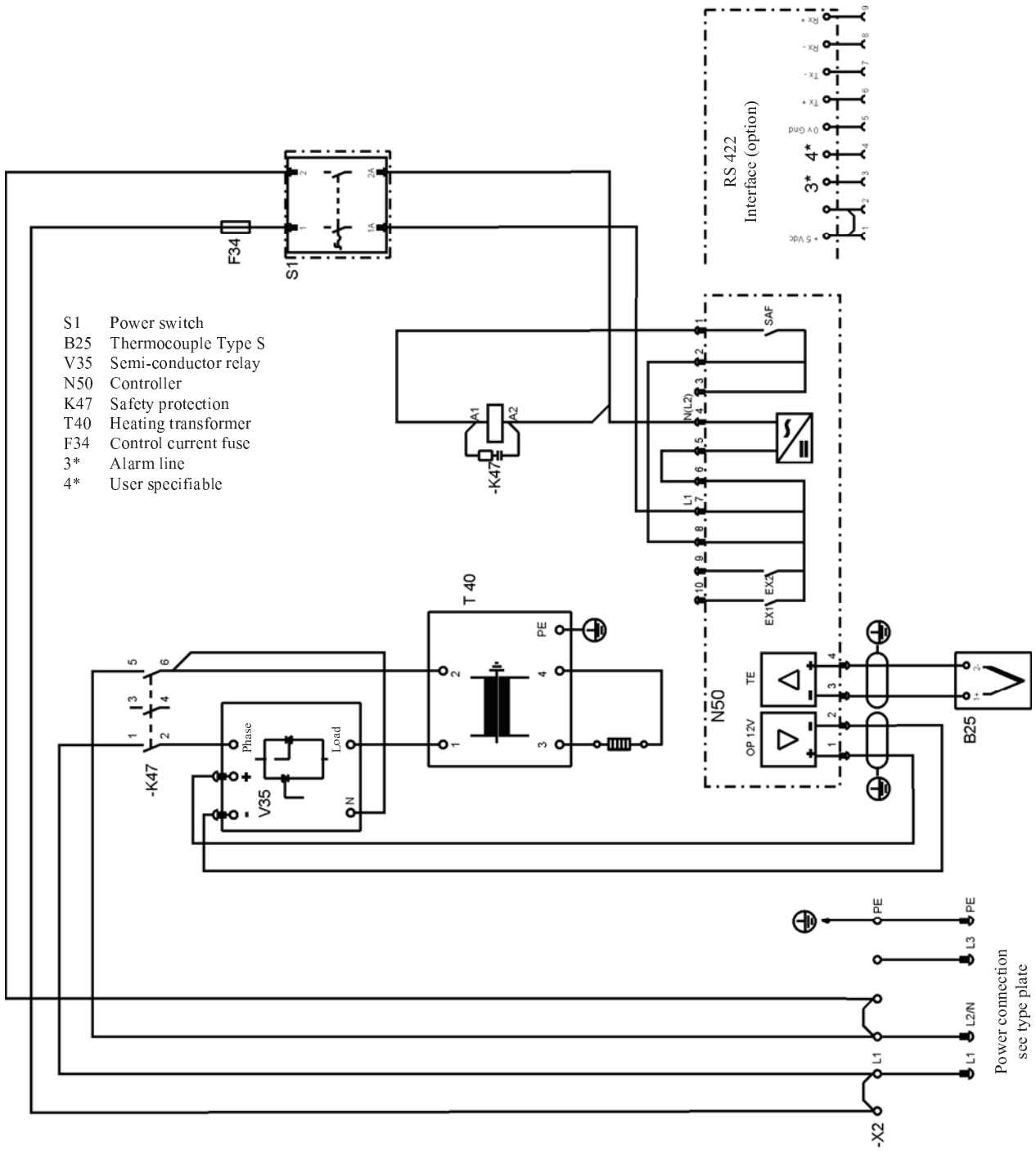

Fig. 21: R .../250-500/13\_200V-240V ~1/N/PE, 2/PE, 50/60Hz

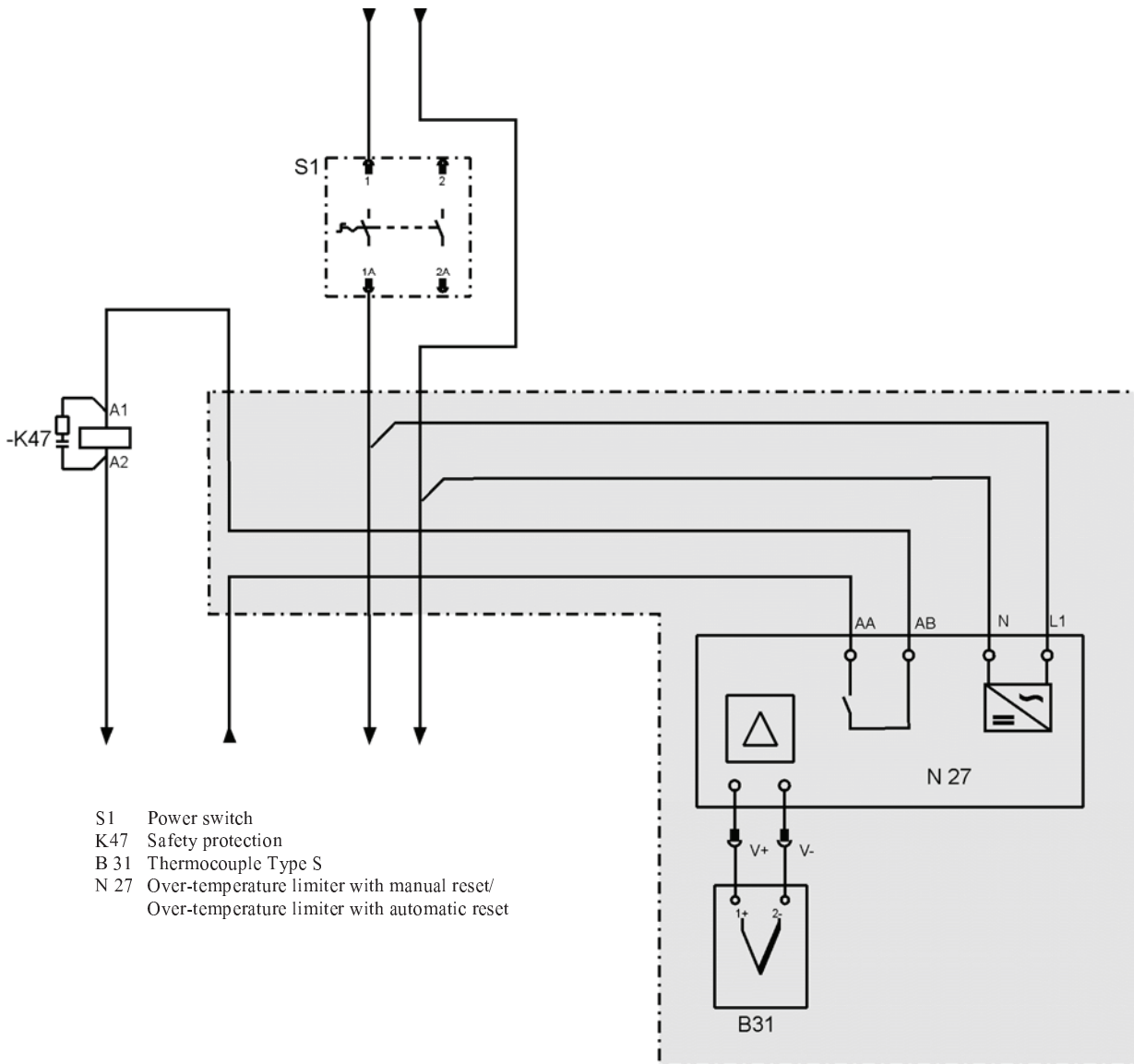

Fig. 22: Over-temperature limiter with manual reset/Over-temperature limiter with automatic reset

## 11 Nabertherm Service



Contact Nabertherm Service at any time for maintenance and repair.

If you have any questions, problems, or requirements, contact Nabertherm GmbH. By mail, phone or e-mail.



### Mail

Nabertherm GmbH  
Bahnhofstrasse 20  
28865 Lilienthal/Germany



### Phone or Fax

Phone: +49 (4298) 922-0  
Fax: +49 (4298) 922-129



### Web or E-mail

[www.nabertherm.com](http://www.nabertherm.com)  
[contact@nabertherm.com](mailto:contact@nabertherm.com)

**When you contact us, please have the type plate details of the furnace or controller at hand.**



Fig. 23: Example: Type plate

## 12 Shut-Down, Dismantling, and Storage

### To be Completed by the Operator

When the furnace is shut down, the following safety information must be observed to prevent serious injury, damage to property, and damage to the environment.

The furnace may only be shut down by authorized, trained personnel.



The following operating materials/parts are to be disposed of by:

---

---

---

---

Oils and other substances that are hazardous to water must be completely removed before the furnace is dismantled for reuse or scrap.

Ensure that operating materials, lubricants, and consumables are disposed of in an environmentally compliant manner. Regulations relating to proper waste recycling and disposal must be observed.

The furnace may be lifted only at the intended points.

Use only the stated lifting and securing equipment to lift the furnace/parts.

Consider a total weight of \_\_\_\_\_kg when choosing suitable lifting equipment.

For transportation, consider a permitted floor weight of at least \_\_\_\_\_kg/m<sup>2</sup>.



Before transporting the furnace, attach the following securing equipment:

---

---

---

---



#### Note

Read the sections on "Safety" and "Transportation"

## 12.1 Transportation/Return Transportation

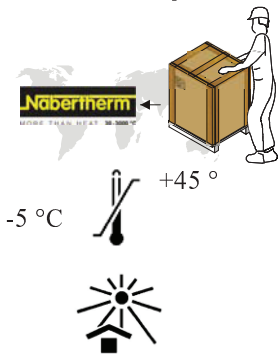

**If you still have the original packaging, this is the safest way to send an furnace.**

Otherwise:

Choose suitable, adequately sturdy packaging. During transportation, packages are often stacked, bumped, or dropped; the packaging acts as external protection for your furnace.

- **Drain all piping and containers before transportation/return transportation (e.g. cooling water). Pump off operating materials and dispose of properly.**
- **Do not subject the furnace to extreme cold or hot temperatures (direct sunlight). Storage temperature -5 °C to 45 ° (-23 °F to 113 °F)**  
**Humidity 5 % to 80 %, non condensing**
- **Place the furnace on a level floor to prevent distortion.**
- **Packaging and transportation may be carried out only by qualified and authorized persons**

If your furnace has transportation securing equipment (see "Transportation Securing Equipment"), use this.

Otherwise, in general:

"Fix" and "secure" (adhesive tape) all moving parts and cushion and protect any projecting parts against breakage.

Protect your electronic equipment against moisture and make sure that no loose packaging material can get inside it.

Fill gaps in your packaging with soft but adequately firm material (e.g. foam mats) and make sure that the equipment cannot slide around in the packaging.

**If the goods are damaged during return transportation due to inadequate packaging or some other breach of duty, the costs will be borne by the customer.**

As a rule:

The furnace is sent without accessories, unless the technician expressly requests them.

Enclose a detailed description of the malfunction along with the furnace – this saves the technician time and costs.

Don't forget to enclose the name and phone number of a contact in case there are any questions.



### Note

Return transportation may only be carried out according to the information given on the packaging or in the transportation documents.



### Note

Transportation and return transportation **not** covered by a warranty claim are paid for by the customer.



### 13 Declaration of Conformity



**EC Declaration of Conformity**  
in accordance with EC directives 2006/95/EEC and  
EMC directive 2004/108/EEC

Hereby

---

**Nabertherm GmbH**  
**Bahnhofstr. 20, 28865 Lilienthal, Germany**

---

declares that the product specified below conforms to the relevant fundamental safety and health requirements of the appropriate EU Directive both in its basic design and construction as well as in the version marketed by us. The declaration will cease to be valid if any modifications are made to the machine without our approval.

### 14 Electrically Heated Tube Furnace

<b>Model</b>	R 50/250/12	R 50/500/12
	R 100/750/12	R 120/1000/12
	R 50/250/13	R 50/500/13
	R 100/750/13	R 120/1000/13

For all furnaces with switchgear and controller

The following harmonized standards were applied:

- DIN EN 61010-1 (07.2011)
- DIN EN 60335-1 (10.2012)
- DIN EN 61000-6-1 (10.2007) , DIN EN 61000-6-3 (09.2011)

Lilienthal, 29.05.2007



Thomas Adamek  
Quality Management



Wolfgang Bartilla  
Research and Development

## 15 Glossary

Terms	Explanation
Smelting	Smelting solid material in furnaces as a result of an increase in temperature is called melting.
Charge	The amount of metal provided for a discontinuously operating furnace in the form of block or circulation material.
Emission	In the sense of the air pollution laws, the air contamination proceeding from a system; in a more general sense, it can also include noise, exhaust heat, odors, water contamination, etc.
Endogas	This is a special <b>protective gas atmosphere</b> of endogas/nitrogen mixtures for the heat treatment of steel and nonferrous metals in industrial furnace systems. A typical gas composition is 20% CO, 40% H <sub>2</sub> and the rest N <sub>2</sub>
Exogas	This is a special <b>protective gas atmosphere</b> of exogas/nitrogen mixtures for the heat treatment of steel and nonferrous metals in industrial furnace systems. A typical gas composition is 10% CO <sub>2</sub> , 5% H <sub>2</sub> and the rest N <sub>2</sub>
Molybdenum disilicide (MoSi <sub>2</sub> )	This material is characterized by good high-temperature stability and thermal conductivity and by its good oxidation and corrosion resistance at temperatures between 1000 and 1600°C. A thin, adhering protective layer consisting of quartz glass (SiO <sub>2</sub> ), which provides the element with good oxidation resistance, forms on the surface of the element at temperatures over 800°C. A wire coated with MoSi <sub>2</sub> can be heated until white-hot in air without the formation of molybdenum oxides.
Molybdenum oxide (MoO <sub>3</sub> )	Molybdenum and silicon oxidation takes place at temperatures of around 550°C. This leads to a yellowish powder consisting primarily of molybdenum oxide (MoO <sub>3</sub> ), which occurs in combination with oxygen.
Oxidation	Oxidation in the narrower and original sense is the chemical reaction of a material with oxygen. The resulting product is an oxide.
Holding mode	Mode of furnaces to hold at a predefined melt bath temperature.
Scale formation	Oxide formation or the formation of surface scale on the metal surface occurs in an oxidizing atmosphere due to a thermal influence (e.g. heat treatment).



