



# FLUID METERING, INC.

## DISPENSERS & METERING PUMPS

### FMI Sub-1 Pump

Capable of Sub-Microliter Adjustments

**NEW PRODUCT**



*Sub-Microliter Dispensing  
Ideal for  
Medical Diagnostic, Biomedical  
and Analytical Instrumentation*

### Features

- Patent Pending Adjustable Link for Precision Displacement Adjustment
- Valveless CeramPump® Technology
- Inert and Chemically Resistant Flow Path
- Precision 1.8° Stepper Motor with Opto Sensor
- Variable Speed Motor
- Dispense Volume As Low As 1  $\mu$ L / stroke
- REACH and RoHS Certified

# FMI Sub-1 Pump

## Specifications

### Pump

- **Dimensions:**  
4.7" x 1.67" x 1.67"  
(119 x 42.4 x 42.4 mm)
- **Shipping Weight:**  
0.85 lb. (0.39 kg) approx.
- **Dispense Volume / Stroke:**  
1/8" up to 5  $\mu$ L / rev  
1/4" up to 25  $\mu$ L / rev
- **Motor Speed:**  
Up to 5  $\mu$ L: 400 rpm  
> 5  $\mu$ L: 1000 rpm
- **Pump Pressure Rating:**  
Not suited for dispensing into pressure

### Motor / Driver

- **Rated Current:**  
2.0 amps / phase
- **Motor Frame:**  
NEMA Size 17
- **Step Angle:**  
1.8° Full Step
- **Operating Temperature:**  
-20°C to 50°C
- **Insulation Class:**  
B

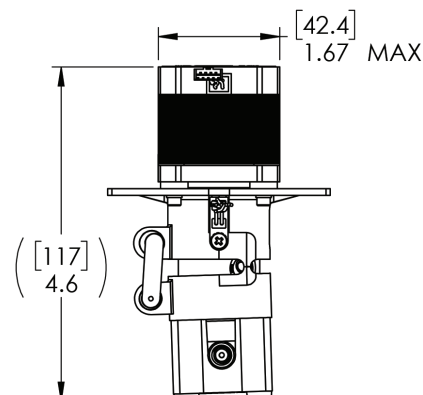

Pump Head P/N	Fluid Path Materials	Seal Materials
H1CKCSM	Ceramic (alumina) PVDF	UHMWPE FKM
H00ZKCSM	Ceramic (alumina) Zirconia PVDF	UHMWPE FKM
H1CTCSM	Ceramic (alumina) ETFE	UHMWPE FFKM
H00ZTCSM	Ceramic (alumina) Zirconia ETFE	UHMWPE FFKM

### Flow Rate Adjustment

- Bushings can be rotated in CW or CCW direction to modify flow rate
- The top bushing is for coarse adjustment  
Coarse Adjustment:  $\pm 25 \mu$ L
- The bottom bushing is for fine adjustment  
Fine Adjustment:  $\pm 6 \mu$ L

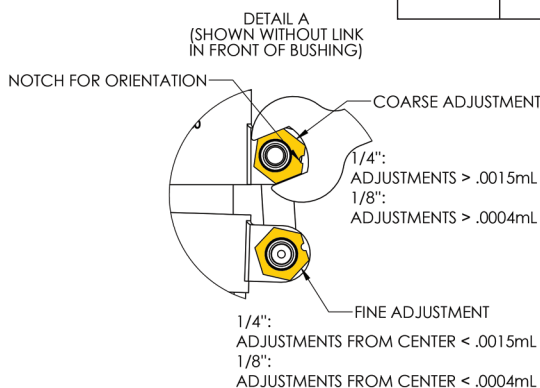

### Benefits:

- Less waste
- Lower reagent consumption reduces cost
- Smaller volumes mean faster throughput and process times
- Microfluidic technology can be used in Point of Care (POC) instruments

## FMI Cerampump® Valveless Metering

The valveless pumping/dispensing function is accomplished by the synchronous rotation and reciprocation of the ceramic piston in the precisely mated liner. One complete revolution is required for each suction/discharge cycle.

