

The background of the entire page is a blue-tinted molecular structure. It features a network of interconnected spheres (atoms) and rods (bonds). The spheres are in various shades of blue and white, and the rods are thin and light blue. The overall effect is a complex, three-dimensional lattice structure.

ENSURING YOUR SAFETY

- 003** LABOR SECURITY SYSTEM SRL
- 005** WHY CHOOSING OUR PRODUCTS
- 007** SAFETYBOX® FLAMMABLES
- 017** SAFETYBOX® CHEMICALS ACIDS BASES
- 029** SAFETYBOX® KEMFIRE®
- 039** SAFETYBOX® COMPRESSED GAS
- 047** CARBOX®
- 059** UTILITIES
- 071** NOTES

LABOR SECURITY SYSTEM

Labor Security System is a leading company in the planning and production of safety cabinets **SAFETYBOX®** for the storage of flammable products, compressed gas cylinders, acids and bases, as well as charcoal filters **CARBOX®**. Pioneering, innovation and constant attention to customer's needs are the features that distinguish the company for over 20 years.



MISSION

To guarantee the highest standards of quality with a reliable, functional and CERTIFIED product, as well as technologically competitive, in compliance with the strictest European safety standards.

CERTIFICATIONS

Since 1995 the company has been **certified UNI EN ISO 9001** by TÜV SÜD-Italy, internationally known, especially for the rigidity of regulations, to which both the company organization and the product realization should comply.

SAFETYBOX® products are certified by **TÜV Production monitored and Safety tested**, which guarantees both the quality of the product and the control of the productive process: from the used materials to the final testing.

The cabinets are **CERTIFIED according to EUROPEAN STANDARDS EN 14470-1, EN 14470-2, EN 14727 and EN 61010-1**. Fire tests of all cabinets of the lines for **flammable and compressed gas cylinders** are carried out at accredited institutions.



CUSTOMER FOCUS AND RESEARCH

The highest attention to the clients' needs reflects not only in products' maximum quality and continuous innovation, but also in **qualified and prompt customer assistance, both pre- and after sale.**

The Company provides the proper training and information to resellers through in-depth courses that take place at Labor Security System showroom. Currently present with its dealers across the country and in continuous expansion in the international market, the Company has a **large warehouse** in which over 400 different cabinets are stored, ready to be shipped to the customer within **24 hours** from receipt of order.

Labor Security System is a member of **Unichim** since February 2011 and has actively been taking part to the normative committee of **CEN** – European Committee for Standardization – for the creation of technical norms with regards to laboratory equipment.



European Committee for Standardization

WHY CHOOSING OUR PRODUCTS



MADE IN ITALY

Made in Italy has always been synonymous with excellence, symbol and value of products that are characterized by durability and attention to details. We carefully check all purchasing processes, testing the quality of each individual component, to maintain the highest quality standards. Our safety cabinets are entirely produced in Italy.

PROMPT DELIVERY

Thanks to the huge availability of products in stock, every model is ready to be shipped within 24 hours from receipt of order.

ASSISTANCE

Prompt and competent pre- and post-sale assistance provided by LSS is a further demonstration of the utmost attention to the customer. Your satisfaction is our priority.

PRODUCT INSURANCE

All cabinets have "Product and Public Liability Insurance" which covers any damage to persons and objects caused by manufacturing defects. The insurance is valid for all lifelong of the cabinet.

TESTING AND TRACKING

Each cabinet is tested in a 1:1 scale; later on a serial number for product traceability is assigned to each cabinet.

ENVIRONMENTAL CARE

Labor Security System offers cutting edge solutions with an eye to sustainable development. Through the use of eco-friendly materials, we are able to offer products that combine maximum effectiveness with energy saving, thereby ensuring the safety of both workers and the environment.

NOT AN ORDINARY MECHANISM

A unique mechanism allows the easiness of cabinets' opening. Designed with door locking device at 50 ° C in compliance with the highest safety standards.

CERTIFIED STORAGE OF CHEMICAL PRODUCTS

LSS is the only company that can provide the product certificate, issued by the accredited institute TÜV SÜD, for the cabinets destined to the storage of CHEMICALS PRODUCTS.

PALLETIZED BASE

Easy handling thanks to the **CERTIFIED** palletized base.

LOCK

All safety cabinets SAFETYBOX® come with a smart locking system that simplifies the replacement of the lock in case of loss and / or breakage of the key.

Also available with digital coding system TOUCH CODE.



SAFETYBOX®
STORAGE OF
FLAMMABLE
SUBSTANCES

odium hydroxyde 0.25 mol/l
 N/4)
 odio hidróxido 0.25 mol/l (N/4)
 atronlaue 0.25 mol/l (N
 UN 1824
 atch Number 1B719071C
 xpiry Date 2013/02

Safety cabinets for the storage of liquid and solid flammable products in compliance with **EN 14470-1, EN 14727.**

INDEX

FLAMMABLES SMART 09
 FLAMMABLES CM 11
 FLAMMABLES UNDERBENCH..... 13
 ACCESSORIES..... 15

AC 1200 S
AC 900 S
AC 600 S

The most elegant, innovative and lighter safety cabinet on the market.
 "TYPE 90" FIRE RESISTANCE – 90 MINUTES.



AC 1200 S



AC 600 S



- Completely produced in pickled steel, 10/10 mm thickness, painted with epoxide acid-proof dusts and passage through thermic tunnel at 200°C. Thickness of painting from a minimum of 60µm (micron) to a maximum of 250µm (micron) as per UNI EN ISO 9001 procedure.
- **Certified palletized base:** for easier transportation of the cabinet.
- **External monolithic construction, internal body resistant to corrosive products.**
- Innovative fire-proof insulation made of highly fire resistant material, completely ecological.
- **Double, inflatable and anti-dust trimmings, with protection against "cold and hot fumes".**
- Door's closure with **thermic device at 50°C. Not electric.**
- **Patented safety catch "Ignis-lock®"** that keeps the doors closed in case of fire.
- Two mechanical certified safety valves with automatic closure at 70 ± 10°C. (Ø 100 mm).
- **3 tray-shaped shelves adjustable in height by racks, and bottom basin;** all made of electrogalvanized steel painted with epoxide acid-proof dusts.
- Security lock with key and extractable cylinder.
- "Danger" warning stickers (DIN 4844 and ISO 3864).
- Grounding connection to discharge build-up of static electricity.
- Levelling feet for balance.
- **"Product and public liability insurance" valid for all lifelong of the cabinet.**
- Usage and maintenance manual.
- **Packaging with "Tipping over system®" device.**

- **LIGHTER**
- **MORE ROOMY**
- **OPENING WITH NO EXTERNAL HINGES**
- **INTERNAL IGNIS-LOCK®**

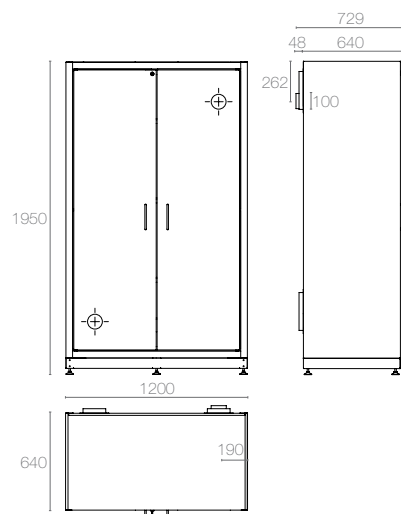

AC 1200 S
 -External dimensions (LxDxH): 1200x640x1950 mm
 -Internal dimensions (LxDxH): 1053x495x1731 mm
 -Weight: 380 Kg
 -Storage capacity: ~902 lt
 -Shelf loading: 80 Kg

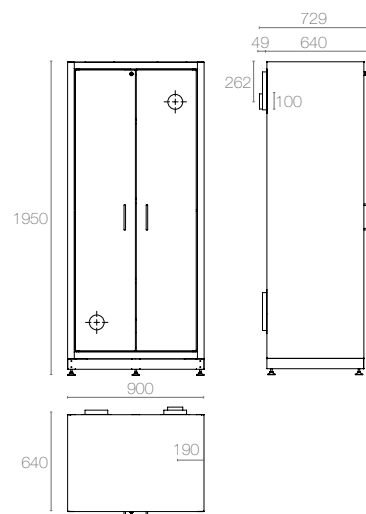

AC 900 S
 -External dimensions (LxDxH): 900x640x1950 mm
 -Internal dimensions (LxDxH): 753x495x1731 mm
 -Weight: 310 Kg
 -Storage capacity: ~645 lt
 -Shelf loading: 80 Kg

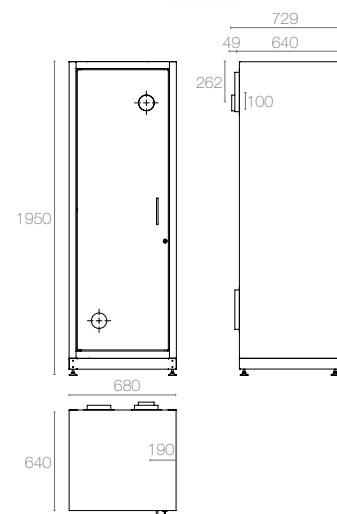

AC 600 S
 -External dimensions (LxDxH): 680x640x1950 mm
 -Internal dimensions (LxDxH): 533x495x1731 mm
 -Weight: 252 Kg
 -Storage capacity: ~456 lt
 -Shelf loading: 80 Kg

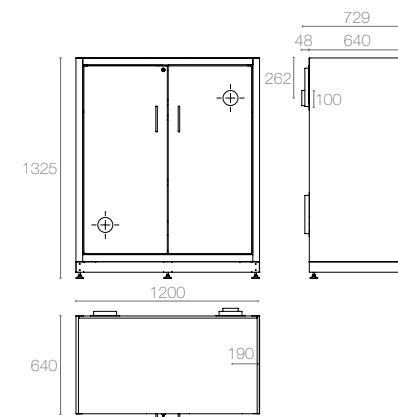

AC 1200/130 S
 -External dimensions (LxDxH): 1200x640x1325 mm
 -Internal dimensions (LxDxH): 1053x495x1110 mm
 -Weight: 275 kg
 -Storage capacity: ~578 lt
 -Shelf loading: 80 Kg

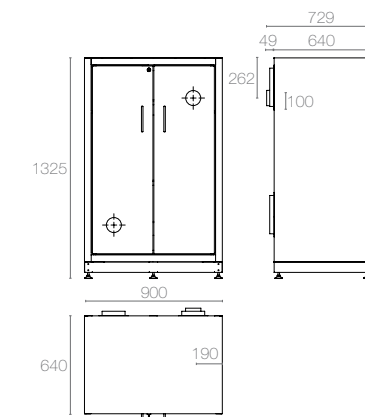

AC 900/130 S
 -External dimensions (LxDxH): 900x640x1325 mm
 -Internal dimensions (LxDxH): 753x495x1110 mm
 -Weight: 224 kg
 -Storage capacity: ~413 lt
 -Shelf loading: 80 Kg

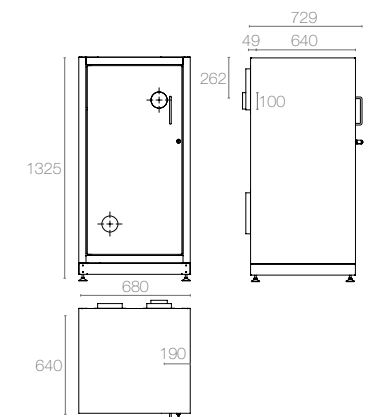

AC 600/130 S
 -External dimensions (LxDxH): 680x640x1325 mm
 -Internal dimensions (LxDxH): 533x495x1110 mm
 -Weight: 187 kg
 -Storage capacity: ~292 lt
 -Shelf loading: 80 Kg

OTHER AVAILABLE MODELS

HEIGHT 1300 MM AVAILABLE ON DEMAND

AC 1200 CM
AC 600 CM

“TYPE 90” fire resistance – 90 minutes TÜV Certified.



AC 1200 CM



AC 600 CM



- Completely produced in pickled steel, 10/10 mm thickness, painted with epoxide acid-proof dusts and passage through thermic tunnel at 200°C. Thickness of painting from a minimum of 60µm (micron) to a maximum of 250µm (micron) as per UNI EN ISO 9001 procedure.
- **Certified palletized base:** for easier transportation of the cabinet.
- **External monolithic construction, internal body resistant to corrosive products.**
- Fire-proof insulation made of highly fire resistant material, completely ecological.
- **Double, inflatable and anti-dust trimmings, with protection against “cold and hot fumes”.**
- Door's closure with **thermic device at 50°C. Not electric.**
- **Patented safety catch “Ignis-lock®”** that keeps the doors closed in case of fire.
- Two mechanical certified safety valves with automatic closure at 70 ± 10°C. (Ø 100 mm).
- **3 tray-shaped shelves adjustable in height by racks, and bottom basin;** all made of electrogalvanized steel painted with epoxide acid-proof dusts.
- Anti-spark hinges.
- Security lock with key and extractable cylinder.
- “Danger” warning stickers (DIN 4844 and ISO 3864).
- Grounding connection to discharge build-up of static electricity.
- Levelling feet for balance.
- **“Product and public liability insurance” valid for all lifelong of the cabinet.**
- Usage and maintenance manual.
- **Packaging with “Tipping over system®” device.**

ACCESSORIES

Easy Going®. Rolling system to easily move the cabinet for short distances. (standard on AC 1200 CM).

OTHER AVAILABLE MODELS

AC 1200 CM E - AC 600 CM E



- 3 fixed shelves, not on racks, with bottom basin.
- No patented safety catch “Ignis-lock®”.
- Light packing

AC 1200 T30 - AC 600 T30

“Type 30” Fire resistance– 30 minutes.

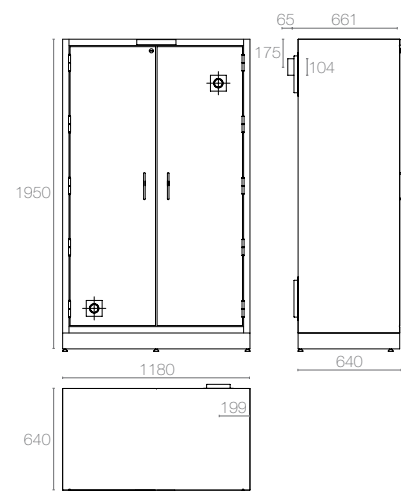

AC 1200 CM
 -External dimensions (LxDxH): 1180x640x1950 mm
 -Internal dimensions (LxDxH): 1015x445x1685 mm
 -Weight: 490 Kg
 -Storage capacity: ~ 761 lt
 -Shelf loading: 80 kg

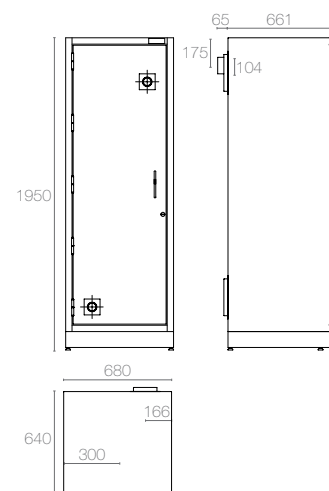

AC 600 CM
 -External dimensions (LxDxH): 680x640x1950 mm
 -Internal dimensions (LxDxH): 515x445x1685 mm
 -Weight: 350 Kg
 -Storage capacity: ~ 386 lt
 -Shelf loading: 80 kg

AC 1200/50 CM
AC 900/50 CM
AC 600/50 CM

“TYPE 90” fire resistance – 90 minutes TÜV Certified.



AC 1200/50 CM



AC 900/50 CM



AC 600/50 CM



KIT05
 Certified device to pour liquids, for underbench cabinets.

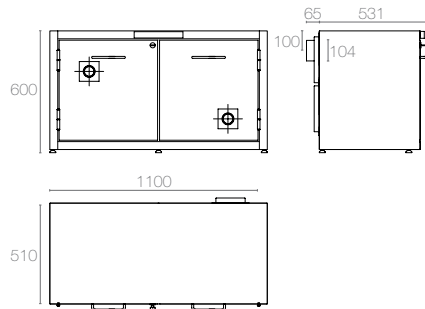

AC 1200/50 CM
 -External dimensions (LxDxH): 1100x510x600 mm
 -Internal dimensions (LxDxH): 935x395x445 mm
 -Weight: 170 Kg
 -Storage capacity: ~164 lt
 -Shelf loading: 80 kg

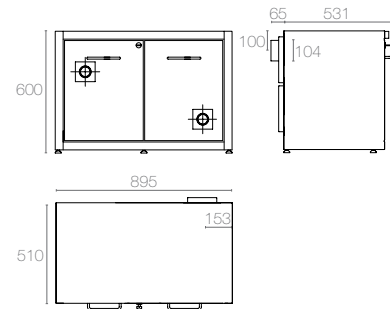

AC 900/50 CM
 -External dimensions (LxDxH): 895x510x600 mm
 -Internal dimensions (LxDxH): 730x335x440 mm
 -Weight: 145 Kg
 -Storage capacity: ~114 lt
 -Shelf loading: 80 kg

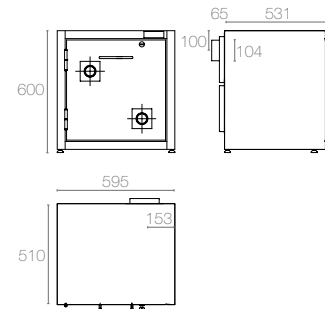

AC 600/50 CM
 -External dimensions (LxDxH): 595x510x600 mm
 -Internal dimensions (LxDxH): 430x395x445 mm
 -Weight: 100 Kg
 -Storage capacity: ~75 lt
 -Shelf loading: 80 kg



- Completely produced in pickled steel, 10/10 mm thickness, painted with epoxide acid-proof dusts and passage through thermic tunnel at 200°C. Thickness of painting from a minimum of 60µm (micron) to a maximum of 250µm (micron) as per UNI EN ISO 9001 procedure.
- **External monolithic construction, internal body resistant to corrosive products.**
- New fire-proof insulation made of highly fire resistant material, completely ecological.
- **Double, inflatable and anti-dust trimmings, with protection against “cold and hot fumes”.**
- Door's closure with **thermic device at 50°C. Not electric.**
- **Patented safety catch “Ignis-lock®”** that keeps the doors closed in case of fire.
- Two mechanical certified safety valves with automatic closure at 70 ± 10°C. (Ø 100 mm).
- **Bottom basin with drilled shelf**, made of electrogalvanized steel painted with epoxide acid-proof dusts.
- Security lock with key and extractable cylinder.
- “Danger” warning stickers (DIN 4844 and ISO 3864).
- Grounding connection to discharge build-up of static electricity.
- Levelling feet for balance.
- **“Product and public liability insurance” valid for all lifelong of the cabinet.**
- Usage and maintenance manual.
- Packaging with **“Tipping over system®”** device.

OTHER AVAILABLE MODELS: WITH DRAWER

AC 1200/50 CM DD - AC 1200/50 CM D
AC 900/50 CM D - AC 600/50 CM D

- Safety closing system for drawer with thermic device at 50°C. Not electric.
- No patented safety catch “Ignis-lock®”.



AC 1200/50 CM DD



AC 1200/50 CM D



AC 900/50 CM D



AC 600/50 CM D

Accessories



KIT05
CERTIFIED device
to pour liquids,
for underbench
cabinets.

**UNICUM
ASPIRATOR
AND FILTER**

in a single box
(possibility to
supply it with
thermostat).



**EXHAUST FUMES
CONVEYOR.**

**ANTI-SPARK
OR ATEX
ASPIRATORS**
220V/230V.



**INTERNAL
FILTRATION
SYSTEM**
with activated
charcoal filter and
Cunctator®.



CUBETTO®
Controlled cooling unit for safety
cabinets **Safetybox®** with
recorded memory device.

ECOBIX® PVC

Container for
polluting liquids
with full/empty
signaling device.
Customized
dimensions.



**STAINLESS
STEEL ECOBOX®**

Container for
polluting liquids
with full/empty
signaling device. Customized
dimensions.



**ADDITIONAL
SHELVES**

made of acid-proof
painted steel or AISI
304 STAINLESS
STEEL.

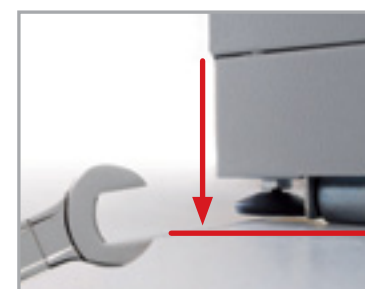

EASY-GOING®

Roller system for
short moving.



EASY-ROLLER®

Rolling system to be
positioned under the cabinet
for easy handling during
logistics.



TOUCH CODE

Opening doors'
system through
fingerprint detection,
with ability to record
multiple users.