

# ANALYTICAL INSTRUMENTATION TIGHT SHUT-OFF DIAPHRAGM VALVES

1.1	DV3-SERIES, 3-WAY DIAPHRAGM VALVE.....	3
1.2	DVS-SERIES, SAMPLE STREAM SELECTION DIAPHRAGM VALVE.....	4
1.3	DGC-SERIES, TIGHT SHUT-OFF, GAS CHROMATOGRAPHIC INJECTION DIAPHRAGM VALVE.....	8
1.4	DV6-SERIES, TIGHT SHUT-OFF, GAS CHROMATOGRAPHIC DIAPHRAGM VALVE.....	9
1.5	PNEUMATIC ACTUATION.....	10
1.6	ELECTRONIC ACTUATION, INTELLIGENT ACTUATOR.....	13
1.7	DIAPHRAGM AND SEAT DESIGN.....	19
1.8	PART NUMBERING.....	21
	DV-SERIES TUTORIAL AND TECHNICAL NOTE.....	26

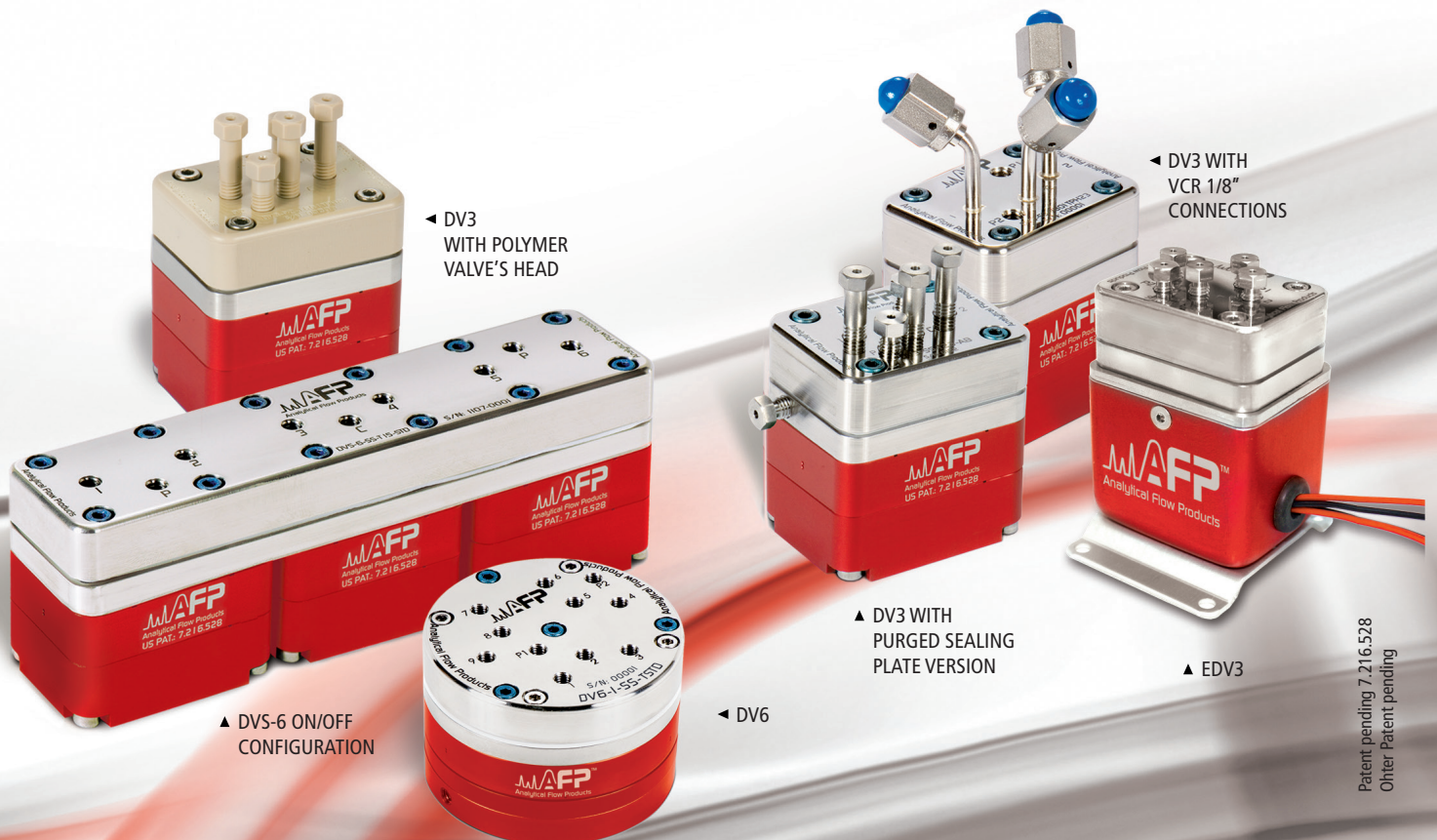

## INTRODUCTION

This is the first real analytical tight shut-off diaphragm valve. They can be used in multiple places in gas chromatographic systems, auto-samplers, sampling and general instrumentation. No dead volume effects, continuous flowpath and purge system make them ideal in many situations. From simple 3-way to complex configuration with timing sequence, the job is easily done.

Wide choice of configurations, from simple pneumatic actuator to fully loaded microprocessor controlled electrical actuator.

DV series valves are available with welded tubes, VCR or analytical fittings. They can be made in a large selection of materials and configured for different operating conditions.

Have a look to the application note and see by yourself how these can make your life much easier.

DV series are also available for industrial platform, like NeSSI, [see NeSSI brochure](#).

## PRODUCTS AVAILABLE FOR ANALYTICAL INSTRUMENTATION

- **DV3, 3-way diaphragm valve**
  - Pneumatic actuation, i.e. DV3
  - Electronic actuation, i.e. EDV3
- **DVS, Sample stream selection**
  - Three configurations:
    - ON/OFF: Pneumatic or electronic actuation
    - Sample By-Pass: Pneumatic or electronic actuation
    - Double Block & Bleed: Pneumatic or electronic actuation
- **DGC, Tight shut-off diaphragm based GC injection valve**
  - Pneumatic or Electronic actuation
  - Internal or external sampling loop
- **DV6, 3 3-Way valve embedded in a compact substrate**
  - Pneumatic or electronic actuation

## COMMON FEATURE DESCRIPTION

- Purge feature to prevent inboard/outboard contamination/fugitive emission and permeation through the diaphragm (optional).
- 100% Helium mass spectrometer leak tested.
- Elimination of any dead volume effects.
- Continuously sweeping flow path.
- Tight positive port shut-off design.
- Working pressure ranging from vacuum to 1000 psig.
- Usable with liquid or gas media.
- Low pressure drop.
- Ports are independently controlled.
- Pneumatic version intrinsically safe.

## FIELDS OF APPLICATION

- Gas chromatograph/Liquid chromatograph/GCMS/LCMS
- On-line gas analyser/Various sampling system
- Automated laboratory sample injection system
- Sample preparation system/Sample concentration system
- Continuous flow analyser
- Purge and trap G.C. Sampler/Head space Sampling
- Total organic compound analyser
- Automated process analyser panel
- Refining and hydrocarbon analyser/Natural gas analyser
- Ion chromatographic system
- And more...

# DV3-SERIES 3-WAY DIAPHRAGM VALVE

## POSITIVE PORT SHUT-OFF DIAPHRAGM VALVE

■ DV3-SERIES

■ EDV3-SERIES



Pneumatic Actuation

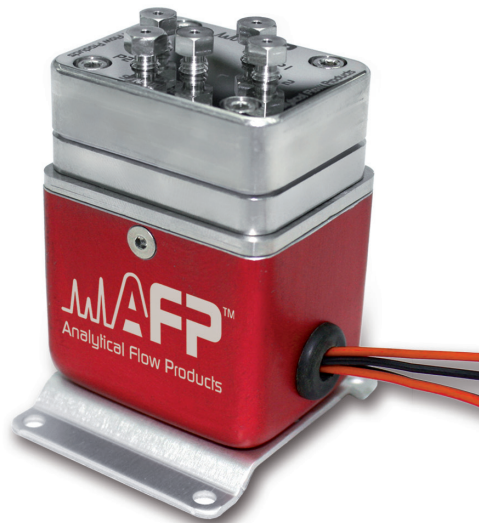

Electronic Actuation

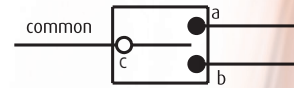
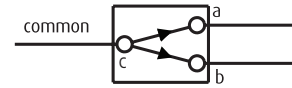
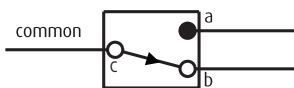
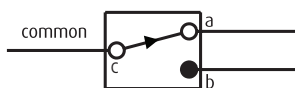
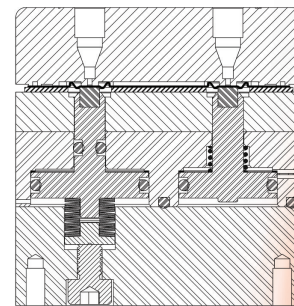
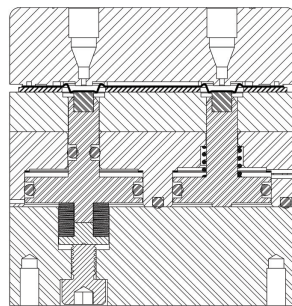
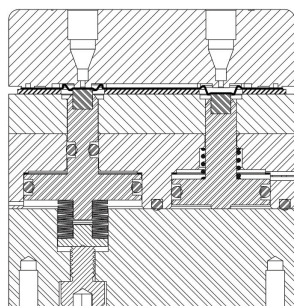
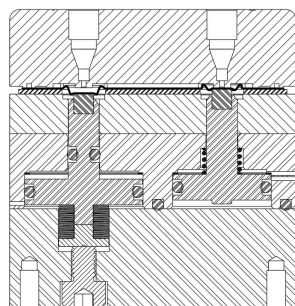
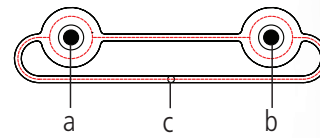
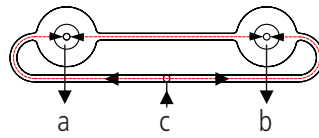
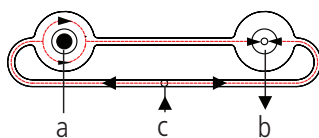
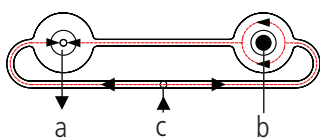

■ FIGURE 1A:  
PORTS a OPEN AND b CLOSED

■ FIGURE 1B:  
PORTS a CLOSED AND b OPEN

■ FIGURE 1C:  
BOTH PORTS OPEN

■ FIGURE 1D:  
BOTH PORTS CLOSED



■ DVS-SERIES



DVS-6 Pneumatic Actuation  
ON/OFF Configuration

■ EDVS-SERIES



Electronic Actuation  
ON/OFF Configuration

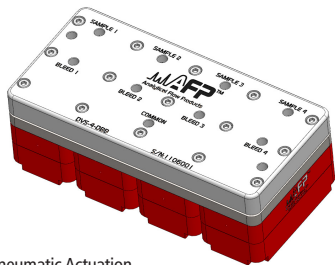

DVS-4 Pneumatic Actuation  
Double Block & Bleed Configuration  
Individual Bleed Vents

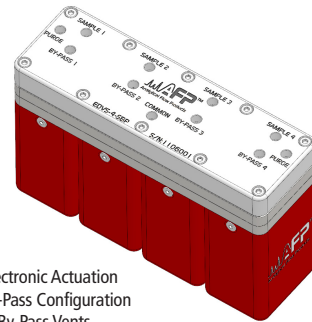

EDVS-4 Electronic Actuation  
Sample By-Pass Configuration  
Individual By-Pass Vents

DVS-SERIES

**ON/OFF STREAM CONFIGURATION**

■ SINGLE STREAM OPERATIONAL STATE #1

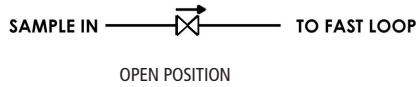

■ SINGLE STREAM OPERATIONAL STATE #2



■ MULTIPLE STREAM FLOWPATH SCHEMATIC

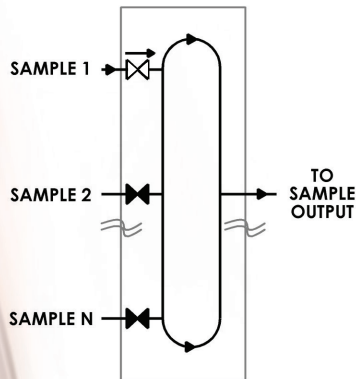

■ MULTIPLE STREAM PHYSICAL FLOWPATH

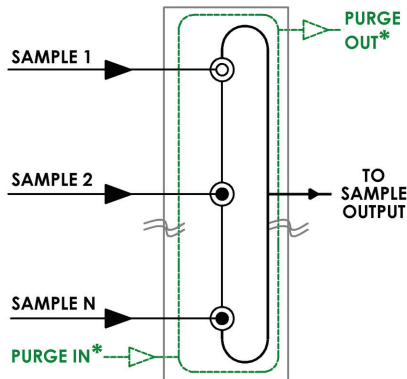

- ALL CHANNELS BUILT ON THE SAME SUBSTRATE
- INTERNAL FAST LOOP INCLUDED

US.PAT.: 7,216,528

\* PURGE IS AVAILABLE AS AN OPTION

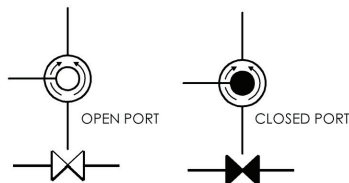



# SAMPLE BY-PASS STREAM CONFIGURATION

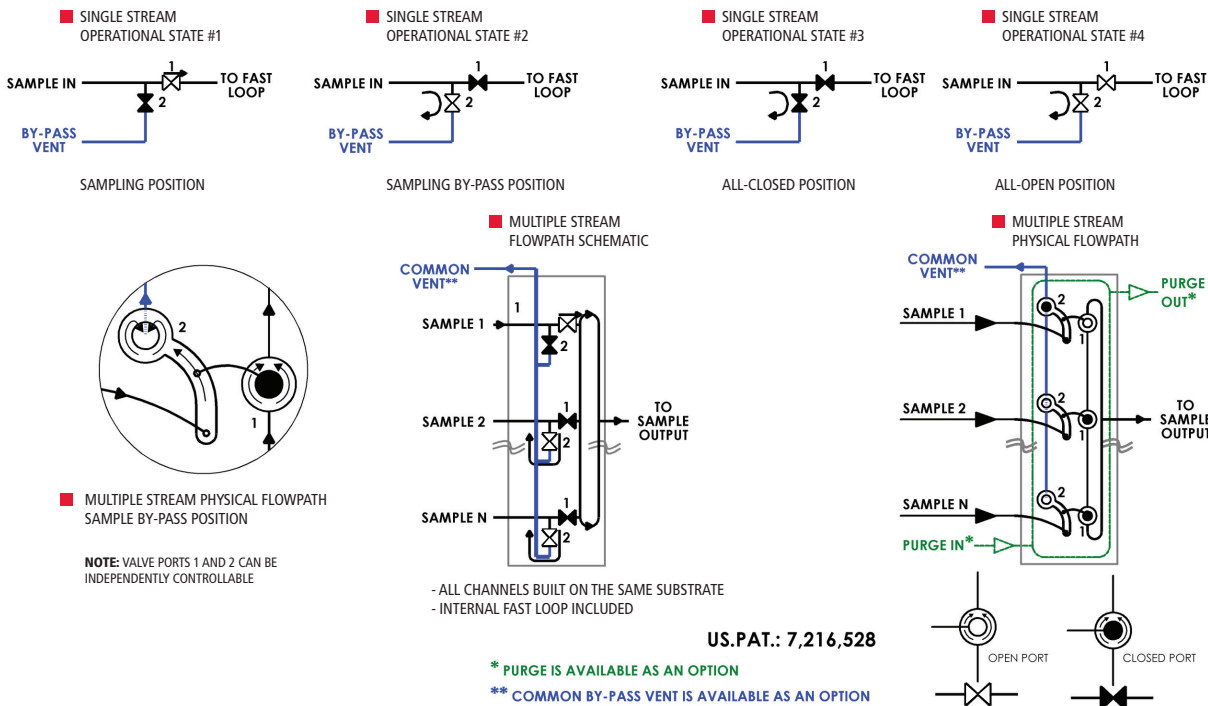

# DOUBLE BLOCK & BLEED STREAM CONFIGURATION

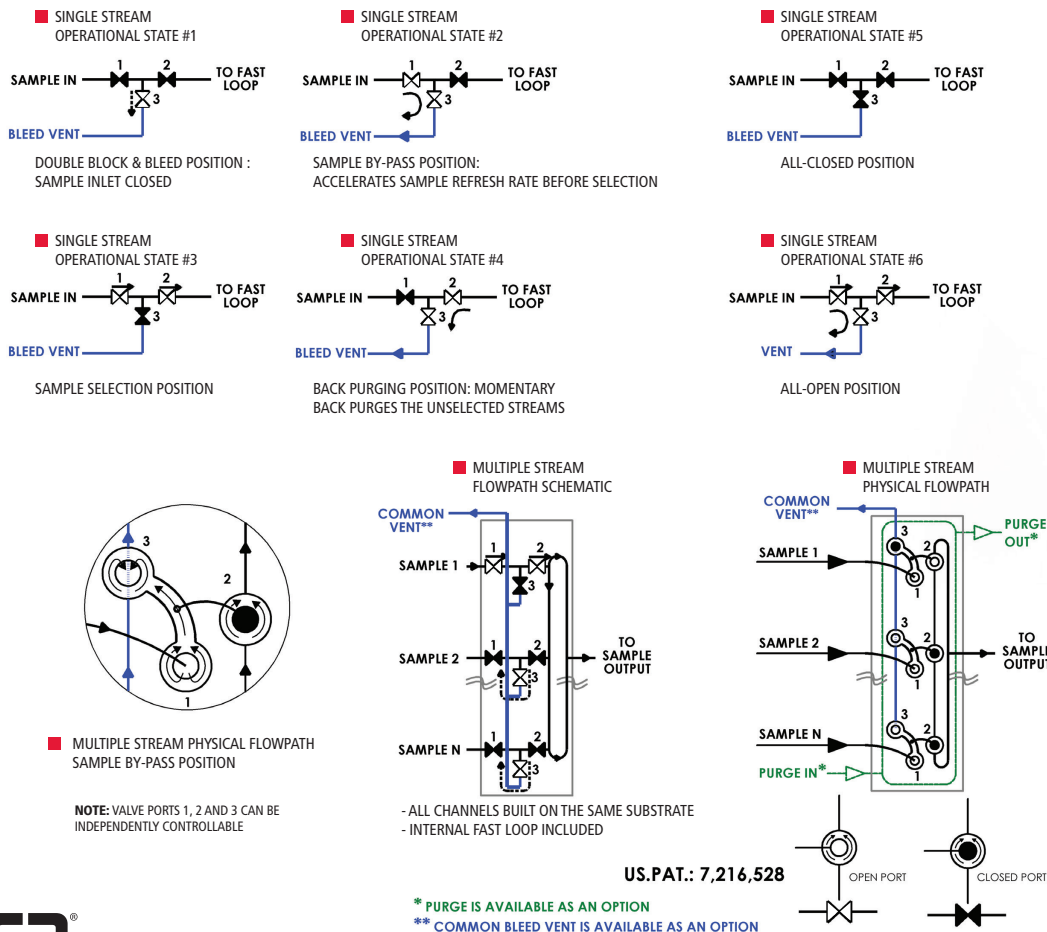

## ACTUATOR CONFIGURATION

If you want a fail-safe assembly to prevent malfunction or unintentional operation of your system, you should choose only one normally open port and all the others normally closed. That way the normally open port will sweep the valve of the carrier gas while the other gases are shut off.

**FAIL-SAFE DEFINITION:** PERTAINING TO A SYSTEM OR COMPONENT THAT AUTOMATICALLY PLACES ITSELF IN A SAFE OPERATING MODE IN THE EVENT OF A FAILURE.

- Replaces standard rotary sample stream selection valve in an analytical panel.
- Drop-in valve system for easy analytical system automation.
- Easy to install and control in OEM gas analysers.
- Replaces a standard sample stream valve design with internal o-rings to provide a contamination free system.
- Used as a building block for an analyzer panel.
- Multiple columns or sample loops selection in chromatographic system.

## FLUID FLOW PATH EXAMPLE

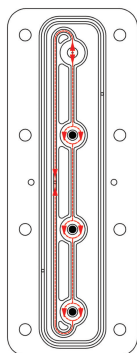

■ (E)DVS-4 Physical FlowPath

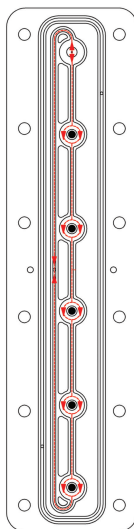

■ (E)DVS-6 Physical FlowPath

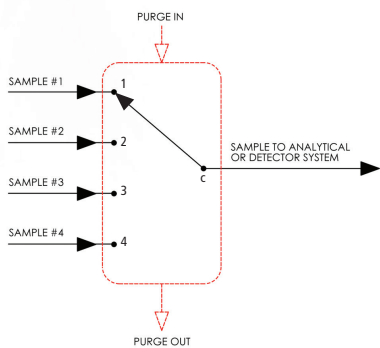

■ (E)DVS-4 FlowPath Schematic

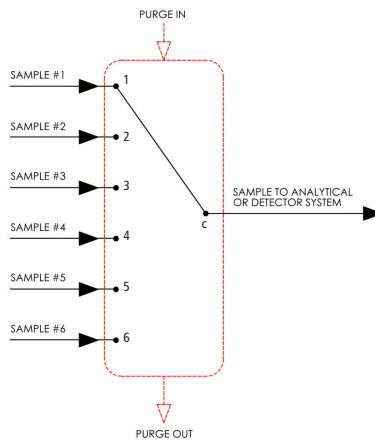

■ (E)DVS-6 FlowPath Schematic

# IN-LINE OPTION

The IN-LINE option gives you the opportunity to put few valves in series. You may increase to any value the number of sample inlet streams. It allows different sampling configuration schemes. The various DVS blocks are externally connected through an appropriate size tubing. This results in a multiple channel system with no dead volume effects and carry over (memory effect). This option is available on all DVS-Series valves. As shown on Figure 10, you can pick two DVS-8 with the in-line option and make a sixteen-port stream selection valve.

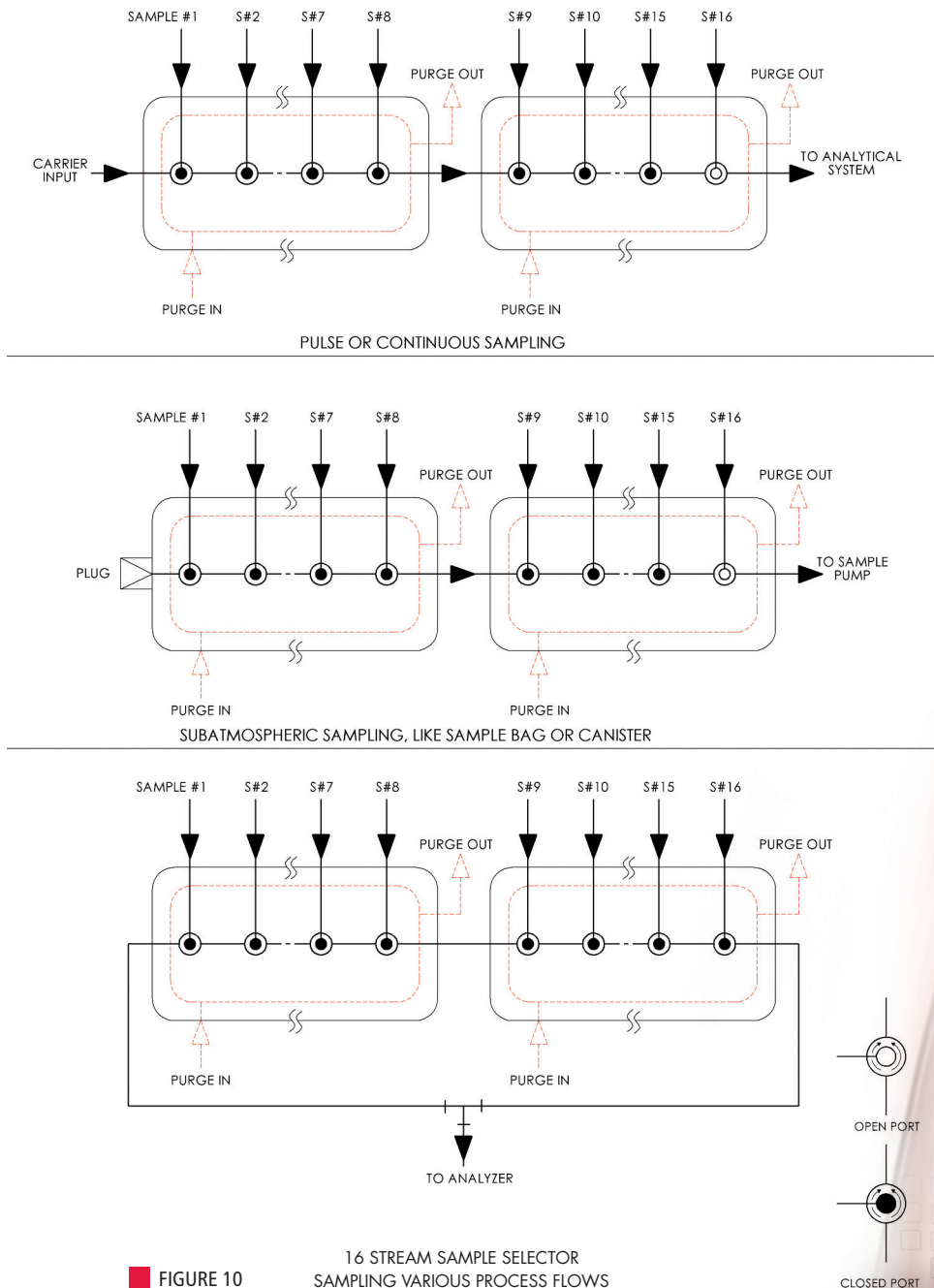

DV-SERIES



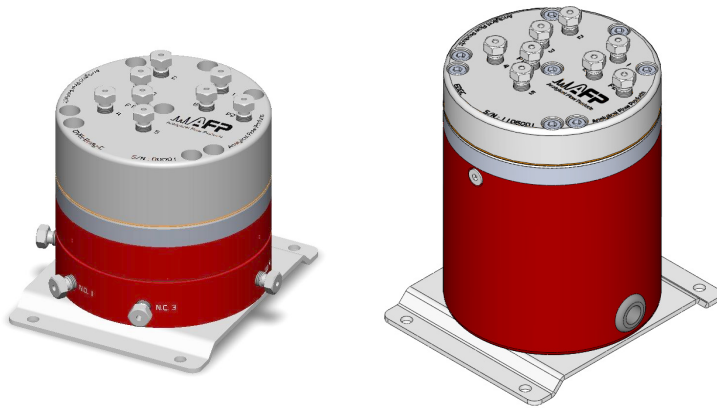

Pneumatic Actuation

Electronic Actuation

- Unique design that leads to new GC methods.
- Internal sampling loop available.

**INTERNAL SAMPLING LOOP**

■ SAMPLING POSITION

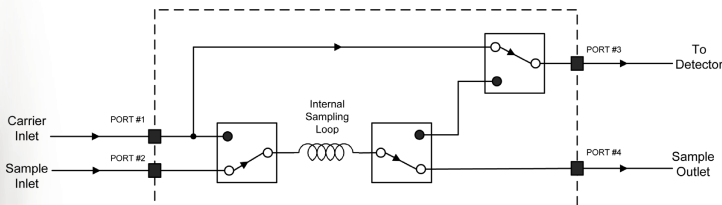

■ INJECTION POSITION

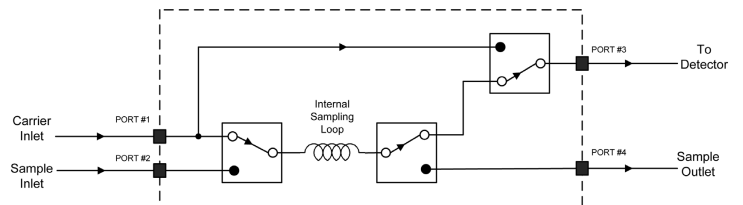

■ WASHING SAMPLE VOLUME POSITION

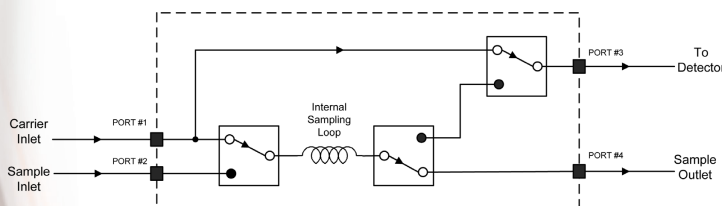

■ (E) DGC PHYSICAL FLOWPATH

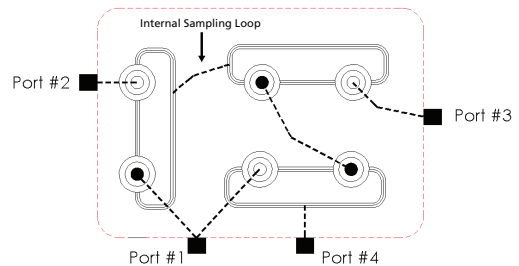

**EXTERNAL SAMPLING LOOP**

■ DGC BLOCK SCHEMATIC - CONFIGURATION

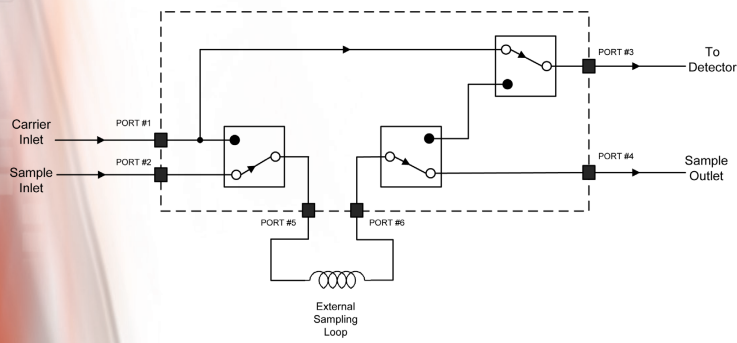

■ (E) DGC PHYSICAL FLOWPATH

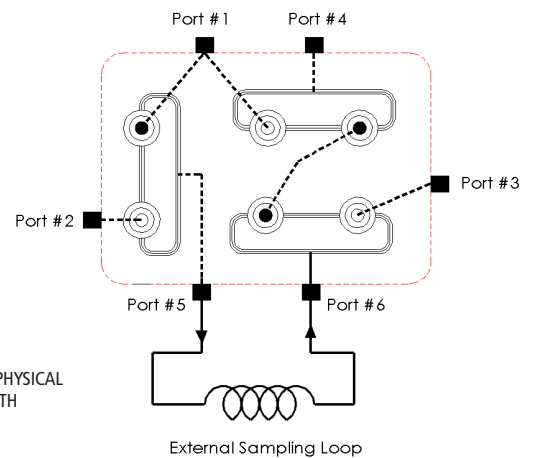

\* Since all ports are independently controlled, other sequences are possible like sequencing injection, washing cycle, sample concentration, etc... See application note for more information.

# DV6-SERIES POSITIVE PORT SHUT-OFF DIAPHRAGM VALVE



Pneumatic Actuation

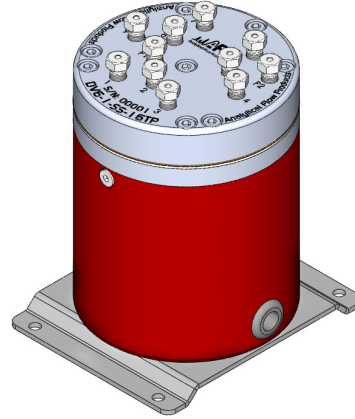

Electronic Actuation

DV-SERIES

## EXTERNAL SAMPLING LOOP

■ SAMPLING POSITION

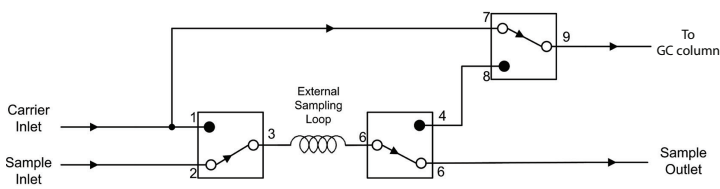

■ INJECTION POSITION

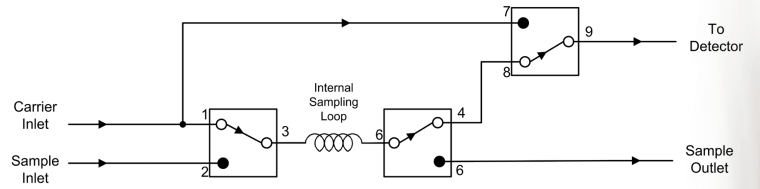

■ WASHING SAMPLE VOLUME POSITION

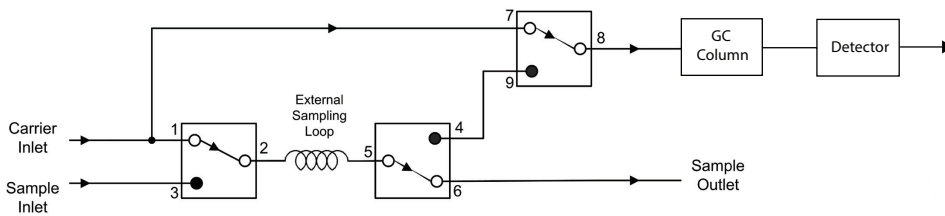

■ (E) DV6 PHYSICAL FLOWPATH

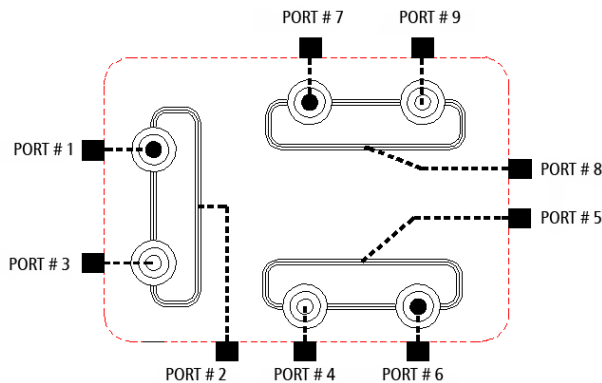

The DV series valves are especially designed for analytical systems. All ports are independently controlled by supplying the pneumatic actuating pressure to their corresponding piston. A port is closed when its associate piston is forced against the corresponding valve's seat, interrupting the flow by directly closing the port. This is what is called positive port shut-off action. The small displacement needed to close or open the port results in a fast switching time. Figure 11 shows a standard DV3 configuration valve's head, and Figure 12 shows a low temperature independent actuator with a normally closed and a normally open configuration. Figure 13 shows a high temperature independent actuator with a double normally closed configuration.

The DV series valves could be used as a simple stand alone valve or a multiple combinations of them could be used to realize complex applications.

The problems that plague many other valve designs to be efficiently used in analytical systems have been corrected. The elimination of any dead volume effects could be achieved with the continuous flow at all time into the valve internal fluid channel, and this even if a port is closed or open. The fluid will flow through an open port or around a closed one. The inboard/outboard leak rate is extremely low, and lower than the detection limit of many leak test systems. This is achieved by the use of a flexible diaphragm that seals the internal valve volume from the exterior environment.

In critical applications an extra protection could be added by the action of purging/sealing grooves machined in the valve head and the sealing plate that could be swept by the appropriate fluid media.



Figure 11  
Standard DV3  
Valve's Head

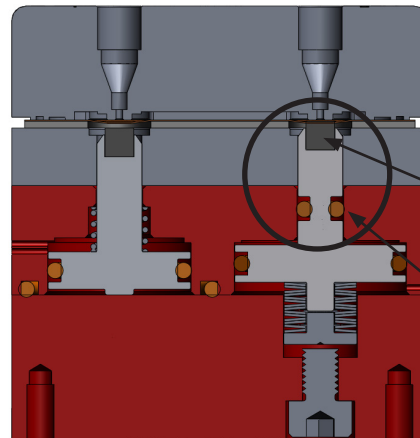

Figure 12  
Independent actuation  
LT model Normally  
Closed/Normally Open  
configuration

CUSHION

ONE-PIECE  
PISTON ROD

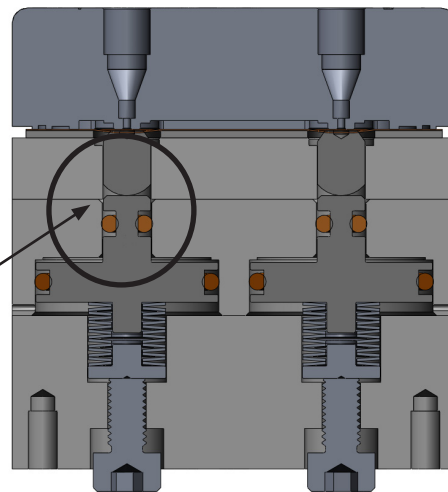

Figure 13  
Independent actuation  
HT model Normally  
Closed/Normally Closed  
configuration

TWO-PIECES  
PISTON ROD

### Pneumatic Valve Actuation Specification

	DV SERIES
Actuation pressure (psig / kPa) (Process gas pressure of 300 psig)	60 / 415
Actuation pressure (psig / kPa) (Process gas pressure of 1000 psig) In Option	125 / 860
Gas Consumption per Actuation (in <sup>3</sup> / cc <sup>3</sup> )	.030 / .50



# ACTUATION CONFIGURATION DV6-S

This actuator has different ways to be configured. If desired, all the normally closed ports can open at the same time. But in some cases, other configurations can be made.

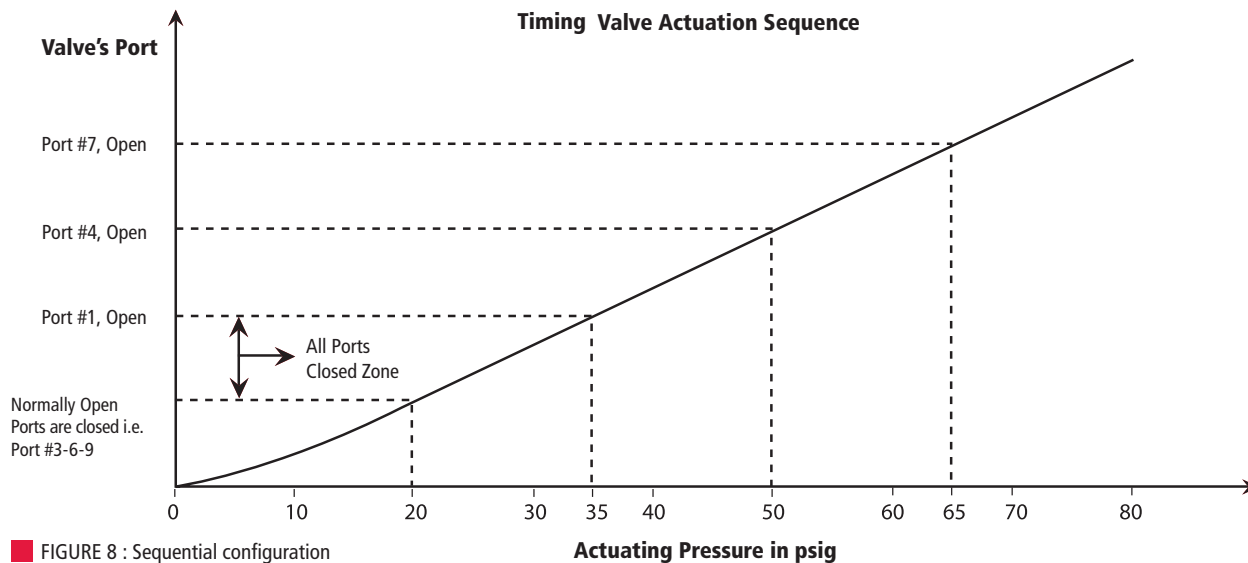

FIGURE 8 : Sequential configuration

When adjusting the set screws below of the normally closed pistons, sets a compressive force or pressure on the Belleville washer stacks, see Figure 12. Depending on how much pressure is applied on the Belleville washer stacks by the corresponding set screws, different pneumatic pressures will be required to open the corresponding ports. This feature allows the following interesting possibilities.

## 1) Adjusting the break before make delay

If the set screws are adjusted in order to require a high pressure to open their corresponding ports, the time that all ports are closed will be longer eliminating even more the risk of cross-port flow or the so-called «mixing». This higher pressure operation will not damage the normally open ports, since piston strokes are limited by the shim stacks.

## 2) Sequential injection mode

This mode allows a sample volume injection without any detector flow and column head pressure variation. Another very interesting operation mode could be done when adjusting each set screw at a different torque. Indeed, the required opening pneumatic pressure for each normally closed piston could be set at a different level, just by adjusting differently the associated set screw.

The following switching sequence is done in about 1 second.

In this case the port #1, 4, and 7 shown in figure 8 are the normally closed ports, associate to their corresponding pistons forced down by their corresponding Belleville washer stacks and associate set screws.

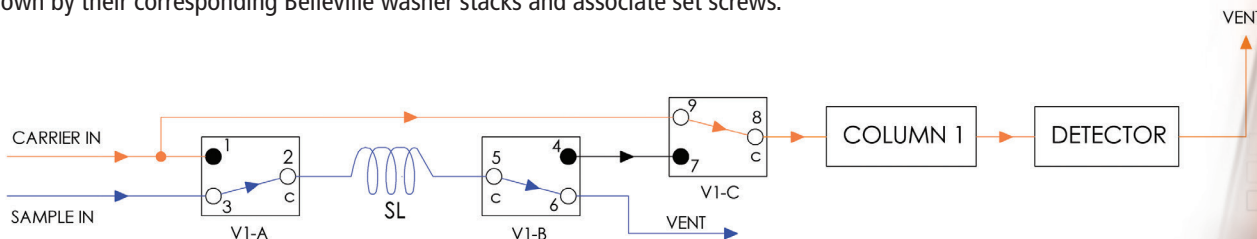
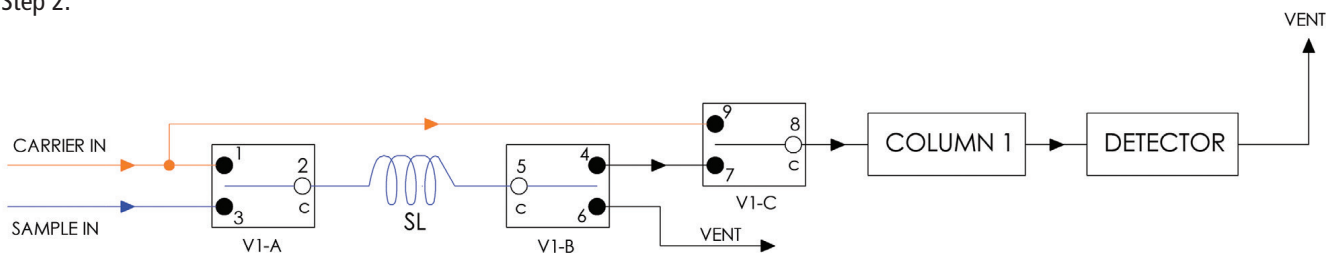

FIGURE 9A: STEP 1: Sampling (No actuating pressure applied)

Now, when actuating pressure reaches 137 kPa (20 psig), all normally open ports are properly closed. Then between 137 kPa to 206 kPa (20 to 30 psig), all valve ports are closed to avoid cross-port flow or «mixing.» This is the valve port position shown in Step 2.



**FIGURE 9B: Step 2: Actuating pressure reach 137 kPa (20 psig)**

Now the actuating pressure is still ramping up at a predetermined rate, to eventually reach 241 kPa (35 psig). Port #1 opens, pressurizing the sampling loop volume at carrier pressure.

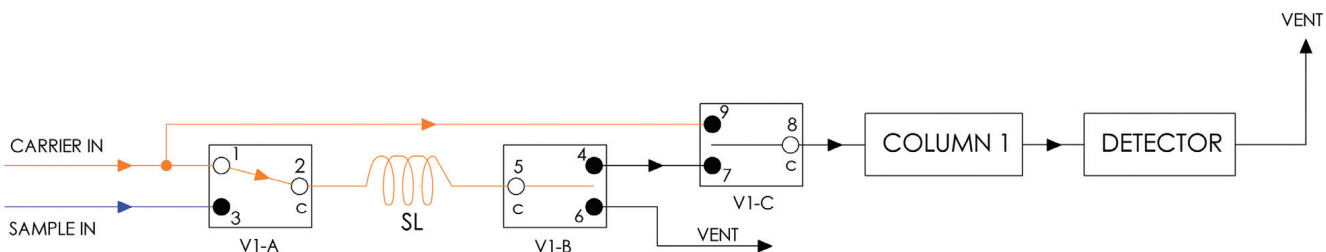

**FIGURE 9C: Step 3: Actuating pressure reaching 241 kPa (35 psig)**

The actuating pressure is still ramping at the same predetermined rate, to eventually reach 344 kPa (50 psig). At this point in time, the port #4 opens connecting the vent side of the sampling loop to port #7, that's still in it's closed position. This pressurizes the tube section to the same pressure as the carrier gas. This is what is shown by the Step 4.

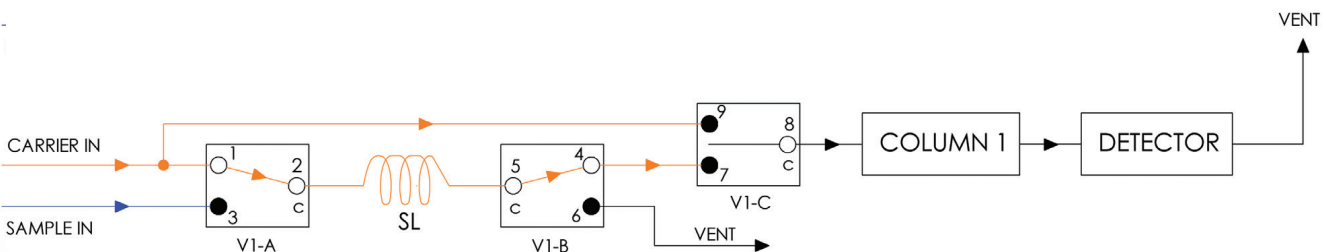

**FIGURE 9D: Step 4: Actuating pressure reach 344 kPa (50 psig)**

Then finally, the actuating pressure reaches 448 kPa (65 psig), opening port #7. This final position of the valve configuration is shown by the Step 5; the sampling loop is injected into the column.

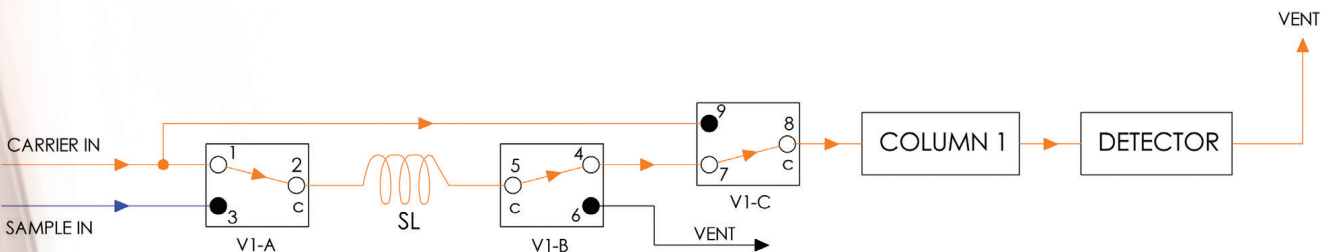

**FIGURE 9E: Step 5: Actuating pressure reach 448 kPa (65 psig)**

**Common features:**

- Microprocessor controlled motors
- Green Power: Consumes power only during actuation. Sleep mode between actuation.
- User selectable default position; normally closed (NC), normally open (NO). Position selected on power up.
- Servoloop torque controlled, compensating for long term wearing; maintaining sealing level over time.
- Various interface for control:
  - Motor Direct Drive.
  - Digital input; Interface with PLC, dry contact, digital electronic.
  - Serial interface, allows daisy chain of multiple valve modules through RS-485.
  - Allows system status report and user's programmable timing sequence and control from PC or microcontroller.
- CE, RoHS

**Applications:**

- Electrically controlled sample stream selection systems.
- Analyzer auto-calibration systems.
- Built-in analyzer sample and calibration gas selection.
- Complex GC configurations.
- Liquid autosamplers.
- Sample panel automation.
- Purge and trap systems.
- GC front end sample processing (Concentration/Purication)
- Syringe pump / dispenser / diluter systems.

**ACTUATION MECHANISM**

In general, port closing or opening is done by controlling a miniature DC motor. Depending on applied voltage polarity to the motor, the output shaft rotates in one direction (clockwise) or the other (counter-clockwise). Speed control is important. This allows the valve to be efficient in different pressure systems by controlling opening and closing parameters (speed, time and priority).

Mechanically, the shaft has a flat side, that is inserted into the motor drive adapter. It transfers the torque from the motor assembly to the threaded coupling through its flat end, which is inserted in the slot at the threaded coupling. The threaded coupling and the motor drive adapter are free to move up and down on the shaft when they rotate. The threaded coupling transfers the rotational torque into a vertical displacement. Then it pushes on a self-aligned plunger. The plunger does not rotate, thanks to the anti-rotation dowel pin. The side of the plunger facing the threaded coupling is treated to reduce friction and wearing while other side is fitted with a compressible cushion, which transfers the vertical force onto the sealing diaphragm. The other side of the diaphragm is facing the valve's seat. Pressing the diaphragm against the valve's seat shuts off fluid flow. Lifting it restores the flow. The plunger is self-aligned and free to move. When the threaded coupling is going up, the plunger will be lifted by the return spring, removing any force on the sealing diaphragm. This makes sure that there is no flow restriction when the valve port is fully open. See Figure 1.

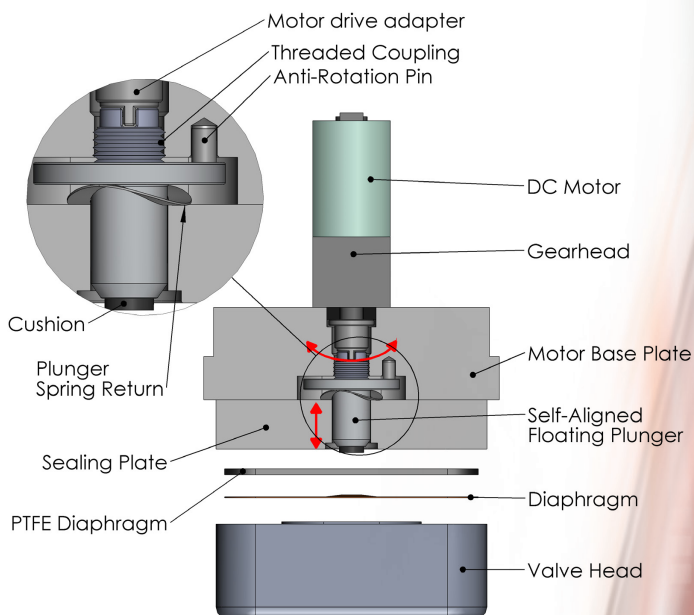

■ **FIGURE 1:** Mechanical assembly



## ELECTRONIC INTERFACE

Figure 2 shows the valve electronic actuation aspects. Each motor is controlled through an H bridge driver. The H bridge allows direction, speed and torque control over the motor. A pulse width modulation technique (PWM) and other parameters are used to reliably control valve operations regarding its specifications (pressure, speed, multiple actuation, diaphragm type).

Diaphragm valve LOW POWER consumption is a good AFP innovation. The mechanical design makes sure that there is no plunger movement when the power is shut off (or H bridge in idle mode) resulting in very low standby power compared to solenoid valve. Safety and application issues can be solved with this feature.

The valve operation could be controlled in three different ways. First, by simply using the corresponding digital input lines; this mimics the traditional way to control closing or opening of a valve port. Applying voltage to a digital input line opens the associate valve port, and vice-versa. The digital input lines are

electrically isolated from the electronic control circuit. These inputs are low power inputs and can be connected to PLC, microcontroller digital outputs or dry contact relay.

The second method uses a predefined BCD (binary coded decimal) instruction format.

The third method is through the use of serial interface. Simple command could be sent to open or close a port. This is not doing more than using the discrete digital inputs for controlling the valve. The only difference is the serial interface is used, typically RS-485. Multiple valve modules could be daisy chained and controlled through serial interface freeing system digital outputs. The serial interface allows also the use of the valve internal microcontroller to control various valve operation sequences, in a user programmed timing sequence.

■ The Figure 2 shows a simplified block diagram of the electronic actuation system.

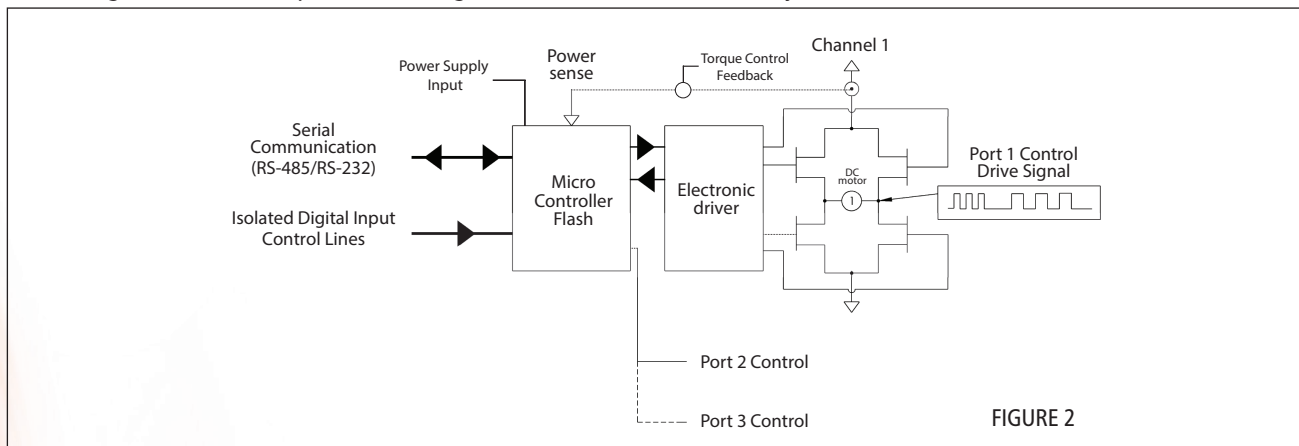

FIGURE 2

# ELECTRONIC SPECIFICATION

TYPICAL FOR AN EDVS4 : 4-INLET SAMPLE STREAM SELECTION VALVE

## FEATURES:

- For any valve configuration, each port is independently controllable.
- No solenoid valve and tubing are required for actuation. This saves space, cost and setup time.
- Green actuation. Indeed, power is consumed only when the valve is actuated. Once the valve reaches its final position (open or closed), no more power is consumed. The valve switches to Standby power mode. For an ON/OFF configuration, the equivalent solenoid valve consumes between 7 and 10W to keep a port open. The EDV Standby is consuming less than 140 mW.
- Direct interface to PLC digital I/O, or any digital controller.
- Serial control interface: Control multiple inlets with a pair of wires.
- Real time wearing compensation: Constant torque.
- RS-485 AFP Command Interpreter
- Software tools available
- Electric and environment self-diagnostic
- CE, RoHS

## GENERAL SPECIFICATION

8 BITS MICROCONTROLLER WITH ( RTC ) REAL TIME CLOCK, FOR PRECISE EVENT TIMING		
LOG AND CONFIGURATION MEMORY	FLASH	1 MEG BYTE
RS-232	SPEED	9600 BAUDS
RS-485 ( 2 WIRES )	SPEED	9600 BAUDS
SUPPLY VOLTAGE MONITORING	ANALOG CONVERTER	10 BITS
INTERNAL TEMPERATURE MONITORING	ANALOG CONVERTER	10 BITS
MOTOR CURRENT MONITORING	ANALOG CONVERTER	10 BITS
OPERATING TEMPERATURE ( ELECTRONIC MODULE )	FAHREHEIT ( °F ) CELSIUS ( °C )	32°F TO 140°F <sup>1</sup> 0°C TO 60°C
CE CONFORM , ROHS		

Note 1 : From the temperature specification. It is important to note that the " valve body " maximum temperature could be much higher and does not affect the electronic module.

## ELECTRICAL SPECIFICATION

SUPPLY VOLTAGE INPUT RANGE ( TRANSIENT AND REVERSEPOLARITY PROTECTOR )	MIN	5 Volts DC
	MAX	24 Volts DC
STANDBY POWER CONSUMPTION	TYPICAL	140 mW <sup>2</sup>

Note 2 : Configurable upon application and pressure

## DIGITAL AND CONTROL INPUT

INPUT PROTECTION	ALL INPUT	DIGITAL ISOLATED
INPUT VOLTAGE AND CURRENT RANGE TO OPEN A PORT	5 Volts DC 12 Volts DC 24 Volts DC	1.6 mA 2.5 mA 5.1 mA
PORT ACTUATION CAN BE CONTROLLED BY SERIAL PORT		
IN NORMAL MODE, PORT CONTROL IS "COMPATIBLE" TO A NORMALY CLOSE PNEUMATIC VALVE PORT OPEN = 5 TO 24 VOLTS PORT CLOSE = GND OR NOT CONNECTED		

## ELECTRICAL POWER CONSUMPTION DURING PORT ACTUATION @ 500 PSI

OPENING POWER	MAX AVERAGE	2000 mW <sup>2</sup> 1500 mW <sup>2</sup>
CLOSING POWER	MAX AVERAGE	2400 mW <sup>2</sup> 2000 mW <sup>2</sup>
CLOSING OR OPENING TIME ( ACTUATION TIME )	TYPICAL	300 msec. <sup>3</sup>

Note 2 : Configurable upon application and pressure

Note 3 : This power is consumed only when port is actuated. Between actuation maximum power consumption is less than 140 mW .

## CONTROL MODE TABLE

### ON - OFF CONFIGURATION HAS ONE CONTROLLABLE PORT.

Operation description	Serial mode	Standard Mode	*BCD mode digital inputs		Valve port State		
	AFP Commands	Digital Input		Digital Input			
		1	1	1	1	1	
Port closed	closed	0	0	0	0	C	
Port open	open	1	1	1	1	O	

1 = Digital input supplied      0 = Digital input to ground      O = Open      C = Closed

### THE SAMPLE BY-PASS CONFIGURATION HAS TWO CONTROLLABLE PORTS.

Operation description	Serial mode	Standard Mode		*BCD mode digital inputs		Valve port State	
	AFP Commands	Digital Input		Digital Input			
		2	1	2	1	2	1
Sample selected	Sample	0	1	0	1	O	C
Sample by-pass	By-pass	1	0	1	0	C	O
All ports closed	All closed	0	0	0	0	C	C
All ports open	All open	1	1	1	1	O	O

1 = Digital input supplied      0 = Digital input to ground      O = Open      C = Closed

### THE DOUBLE BLOCK & BLEED HAS THREE CONTROLLABLE PORTS.

Operation description	Serial mode	Standard Mode			*BCD mode digital inputs			Valve port State		
	AFP Commands	Digital Input			Digital Input					
		3	2	1	3	2	1	3	2	1
Sample selected	Sample	0	1	1	0	0	1	C	O	O
Sample by-pass	By-pass	1	0	1	0	1	0	O	C	O
Back purging unselected streams	Back Purge	1	1	0	0	1	1	O	O	C
Sample isolated, bleed port open	DBB	1	0	0	1	0	0	O	C	C
All ports closed	All closed	0	0	0	0	0	0	C	C	C
All ports open	All open	1	1	1	1	1	1	O	O	O

1 = Digital input supplied      0 = Digital input to ground      O = Open      C = Closed

\* BCD control mode is selected with the help of the internal dip switches. Please see user's instructions for detail.

In BCD and serial control modes, the driver makes sure that valve ports are operated in the appropriate sequence, i.e., for example, break before make.



## OPTION

### GUIDELINES FOR VALVE CONFIGURATION

#### Valve's head configuration

Since there is no one size fit all application valve, the system designer must select the appropriate valve configuration that will fulfill the needs of the application. To achieve this, the following parameters for any particular design must be considered :

- Valve head material, i.e. metal, polymer or ceramic
- Diaphragm type
- Operating pressure and temperature
- Valve process fitting type; compression, AFP Lip Seal Fitting\* or VCR
- Purged sealing plate
- Hard or soft seat

\*Patent pending

As rule of thumb, one must take into consideration the effects that may have on a particular application, the adsorption, the absorption, the out gassing, the permeation and the chemical inertness of the various valve materials in contact (i.e. the so called "wetted parts") with the fluid to be controlled. The following will help the system designer to understand various DV series possible configurations. It may be used as a general guide line. For example, if the system where the valve would be installed is working with an ECD (i.e. electron capture detector) any material releasing electron absorbing compounds will kill the detector sensitivity. This is the case with some fluoropolymer that may release halogen compounds. In this case a Teflon® type diaphragm would not be a right choice. However in some other applications, Teflon® type diaphragm could be an excellent choice. Another example of this fact is if the valve is to be installed in a system measuring low level of moisture or oxygen, surface adsorption and diaphragm permeation, absorption and out gassing are of prime importance. Not only the valve itself must be considered, but also its operating environment. In such case, operating the valve at higher temperature will have a major impact on system performance. Working with corrosive gases, for example chlorine or acid (like HCL), will also call for specific valve materials.

**In brief, the final configuration of a DV valve is application driven.**

#### STANDARD CONFIGURATION

The DV basic standard version has a valve head made of 316L grade stainless steel. The diaphragm is made of a multilayer polymer, i.e. Teflon®/ Polyimide. The maximum operating temperature defined as standard range is 180°C. The standard operating and test pressure is 500 psig (3345 kPa). Minimum operating pressure is vacuum. The diaphragm and other parts of the valve are easily replaceable. All the port connections are 1/16" single ferrule type with AFP® high quality finish.



## EXTRA PURGE CONNECTION

The DV is also available with an extra purge connection. These purge connections allow the select purge fluid to purge the back side of the diaphragm, depending on a particular system requirements.

This allows :

- Working at higher pressure by equilibrating the pressure on both side of a diaphragm
- Eliminating permeation problem through the diaphragm. (Gas application)
- Reducing hazard risk when working with dangerous media.
- Real time diagnostic for critical operation. This is done by monitoring the purge fluid on the purge vent.



## DV3 WITH 1/8" VCR AND/OR OTHER FITTING CONNECTIONS

DV3 could be also fit with 1/8" VCR brazed fittings for process port connections. This configuration could be required for semiconductor and vacuum applications. It also works better for extended time columns, traps or sample isolation due to high level of sealing integrity.

Other kind of fitting connections may also be used to respond to your needs, like 1/4-28, NPT, compression fittings, etc...

All DV series valves are available for the NeSSI™ surface mounting standard platform.



## OPTIONNAL VALVE HEAD MATERIALS FOR CHEMICALLY INERT AND CORROSIVE APPLICATION

For application requiring chemically inert material in regard to the process fluid, for example, corrosive or some organic compound, the DV valve head could be made of polymer, such as PEEK™, ceramic or other appropriate materials. This is often required in the field of liquid chromatography or mass spectrometry. In such configurations, all wetted parts would be made in materials compatible with your applications.



## SEAT OPTION



## HARD SEAT

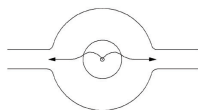

PORT OPEN

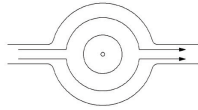

PORT CLOSED

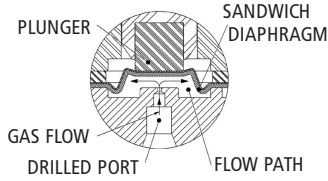

■ FIGURE 1A - Hard seat

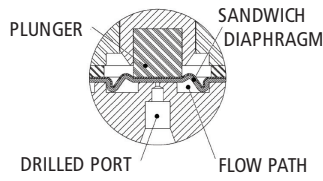

■ FIGURE 1B - Hard seat

## SOFT SEAT

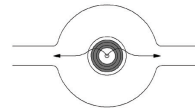

PORT OPEN

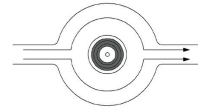

PORT CLOSED

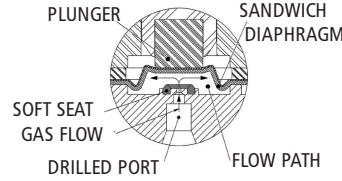

■ FIGURE 1C - Soft seat

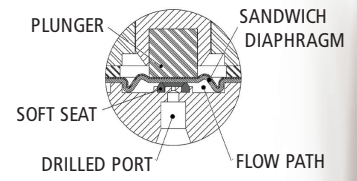

■ FIGURE 1D - Soft seat

## DIAPHRAGM MODEL, TYPICAL FOR DV3 SERIES

- Single layer of selected polymer (Polyimide/Teflon®/PEEK™)
- Multilayer Teflon®/Polyimide (general purpose, longer lifetime)
- Multilayer, very low absorption and permeation
- Metalized, i.e. selected polymer with metal deposition on it.
- Metal only (require valve head soft seat configuration) or coated valve's head
- Stacked layer
- Custom (example: Teflon®/Gold/Polyimide)





## ACTUATOR CONFIGURATION

DV series valve pneumatic actuator could be driven by only one solenoid, i.e. all ports actuated at the same time with a break before make action, or by one solenoid valve for each port, so they would be independently controlled.

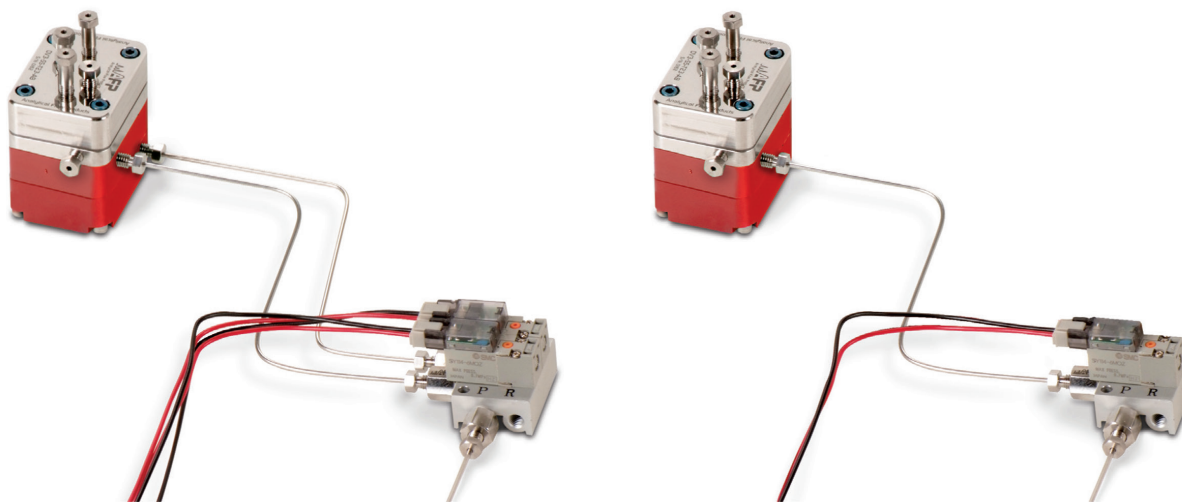

## CUSTOM REQUEST

Please consider AFP as a partner in your projects. If you have any special needs, we will be glad to help you in customizing our products fitting your specific applications. For example DV3 has been made with a longer fitting pilot detail to drop in disc frit to be used as particle filter. Longer pilot detail allows tubing to be fit in other standard fittings without the need to cut it and replacing ferrules.

N.B. : AFP® is also manufacture ring filtering unions with the same characteristic.

## ACCESSORIES

- Electronic timer / sequencer / and driver board, with software. Allow easy interface between third party software/hardware system and multiple DV series valves USB interfaces and software.
- 3-way solenoid valves and manifolds including electrical connector.

For more information, please ask for specific product information sheet.

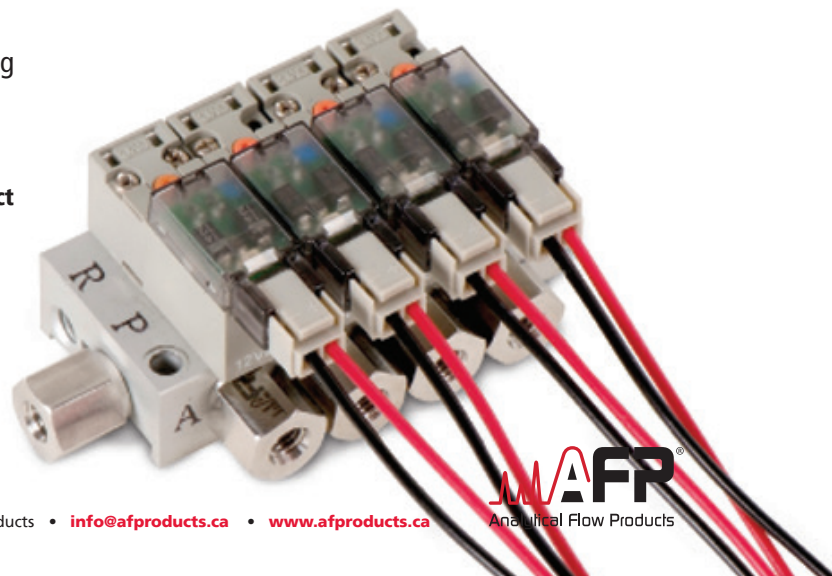



## DV3-SERIES CONFIGURATION / PNEUMATIC ACTUATION

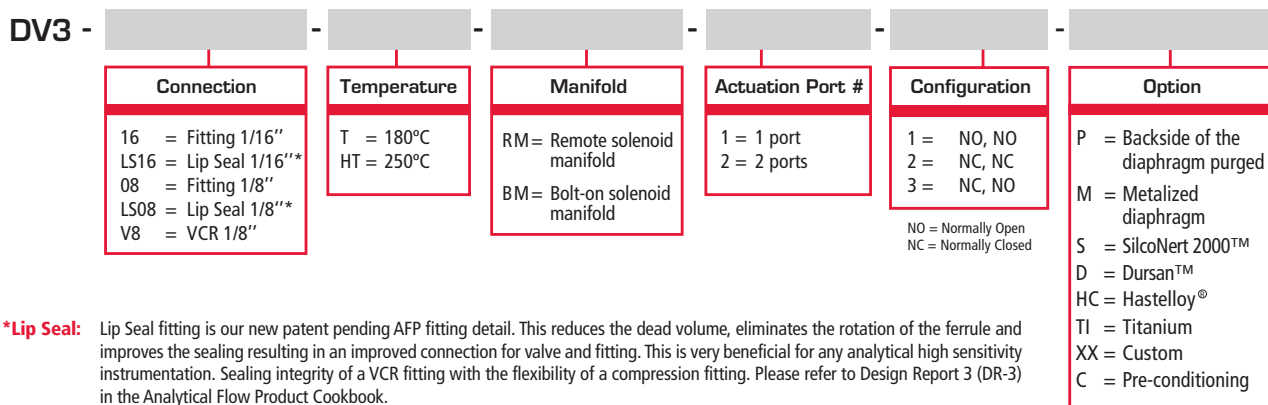

## EDV-3 SERIES CONFIGURATION / ELECTRONIC ACTUATION

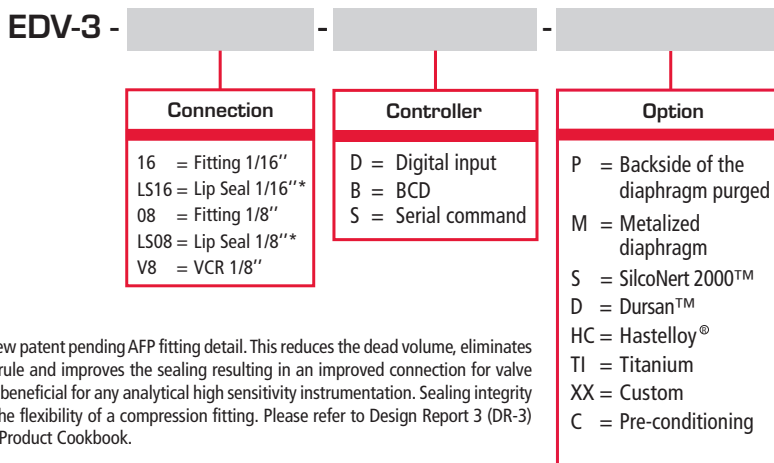

## DVS-SERIES CONFIGURATION / PNEUMATIC ACTUATION

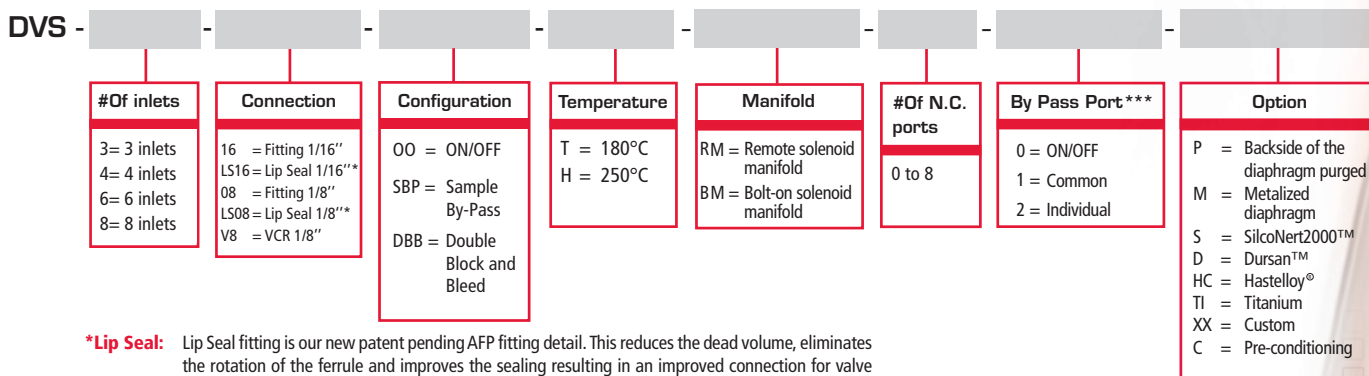

## EDVS SERIES CONFIGURATION / ELECTRONIC ACTUATION

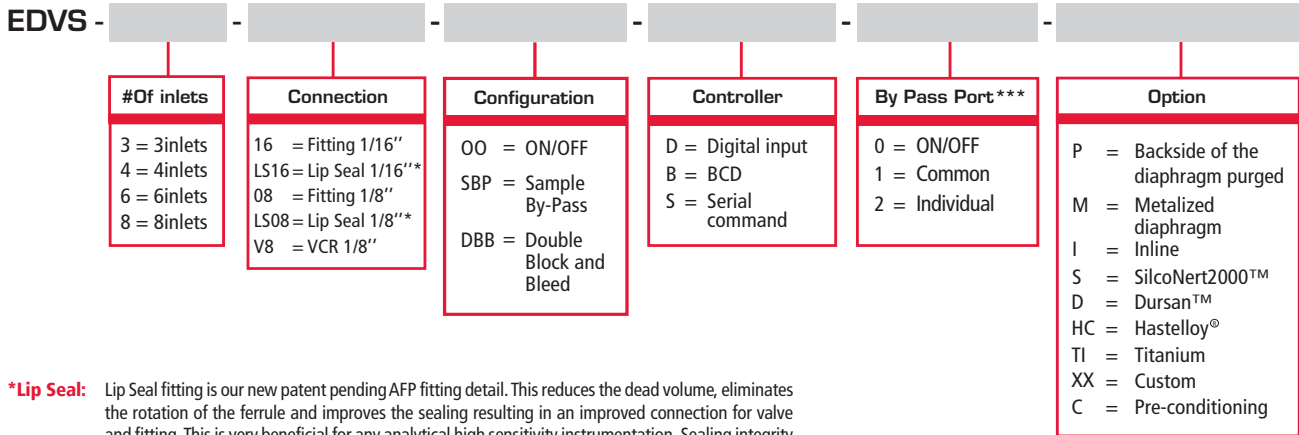

**\*Lip Seal:** Lip Seal fitting is our new patent pending AFP fitting detail. This reduces the dead volume, eliminates the rotation of the ferrule and improves the sealing resulting in an improved connection for valve and fitting. This is very beneficial for any analytical high sensitivity instrumentation. Sealing integrity of a VCR fitting with the flexibility of a compression fitting. Please refer to Design Report 3 (DR-3) in the Analytical Flow Product Cookbook.

\*Patent Pending

\*\*\* 0 = ON/OFF = When used with ON/OFF configuration  
1 = Common = One common port for all channels  
2 = Individual = One port for each channel

## DGC SERIES CONFIGURATION / PNEUMATIC ACTUATION

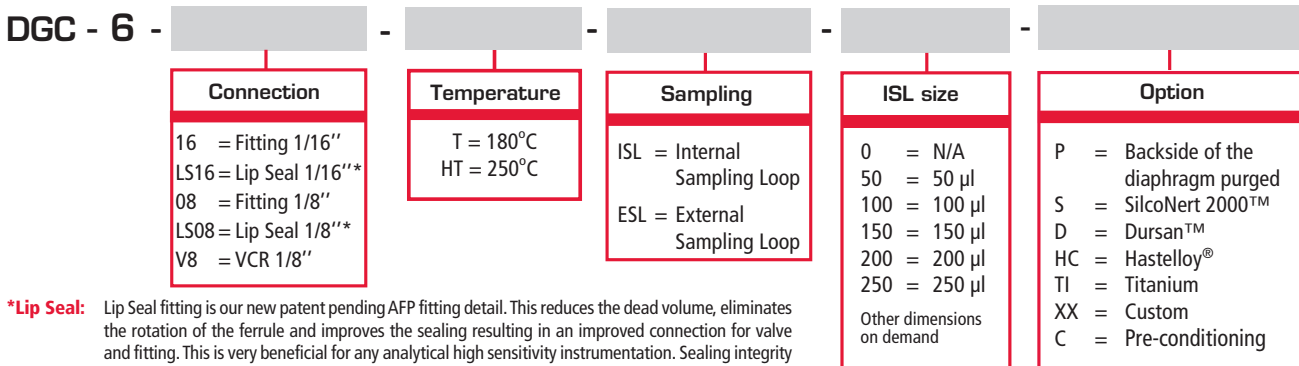

**\*Lip Seal:** Lip Seal fitting is our new patent pending AFP fitting detail. This reduces the dead volume, eliminates the rotation of the ferrule and improves the sealing resulting in an improved connection for valve and fitting. This is very beneficial for any analytical high sensitivity instrumentation. Sealing integrity of a VCR fitting with the flexibility of a compression fitting. Please refer to Design Report 3 (DR-3) in the Analytical Flow Product Cookbook.

\*Patent Pending

## EDGC SERIES CONFIGURATION / ELECTRONIC ACTUATION

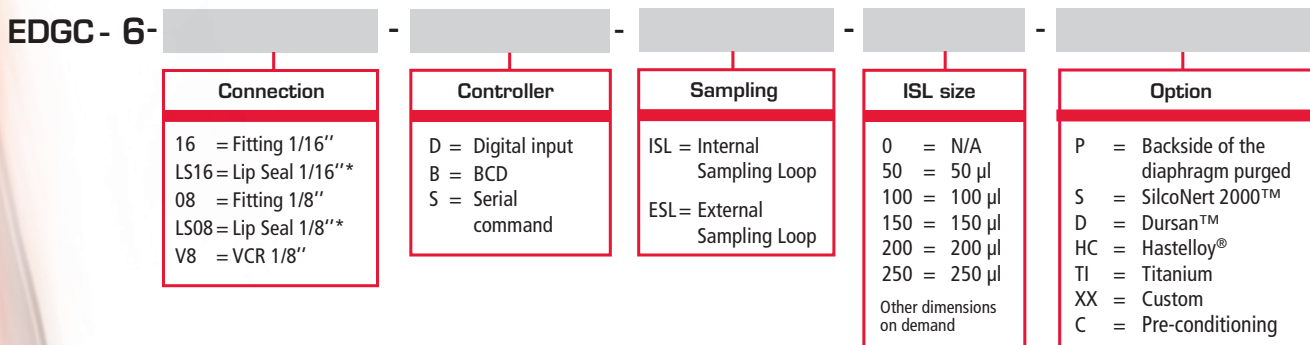

**\*Lip Seal:** Lip Seal fitting is our new patent pending AFP fitting detail. This reduces the dead volume, eliminates the rotation of the ferrule and improves the sealing resulting in an improved connection for valve and fitting. This is very beneficial for any analytical high sensitivity instrumentation. Sealing integrity of a VCR fitting with the flexibility of a compression fitting. Please refer to Design Report 3 (DR-3) in the Analytical Flow Product Cookbook.

\*Patent Pending

## DV6-SERIES CONFIGURATION / PNEUMATIC ACTUATION

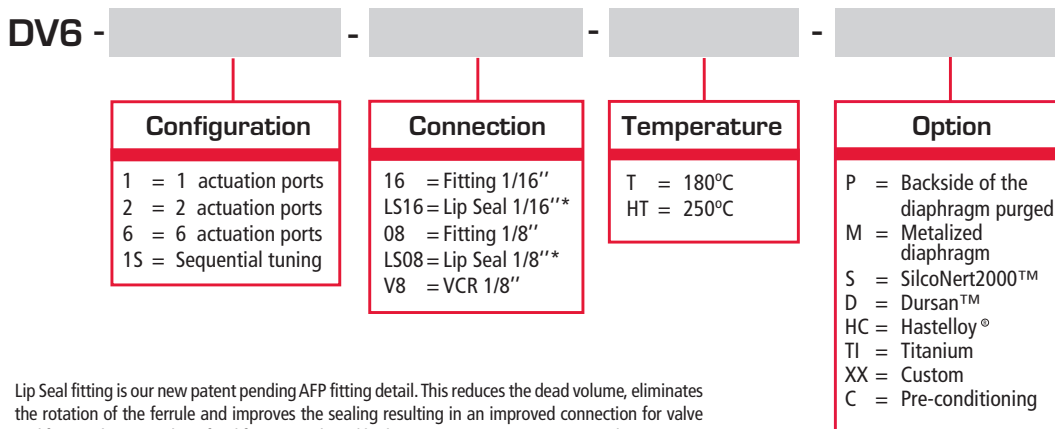

**\*Lip Seal:** Lip Seal fitting is our new patent pending AFP fitting detail. This reduces the dead volume, eliminates the rotation of the ferrule and improves the sealing resulting in an improved connection for valve and fitting. This is very beneficial for any analytical high sensitivity instrumentation. Sealing integrity of a VCR fitting with the flexibility of a compression fitting. Please refer to Design Report 3 (DR-3) in the Analytical Flow Product Cookbook.

\*Patent Pending

## EDV6-SERIES CONFIGURATION / ELECTRONIC ACTUATION

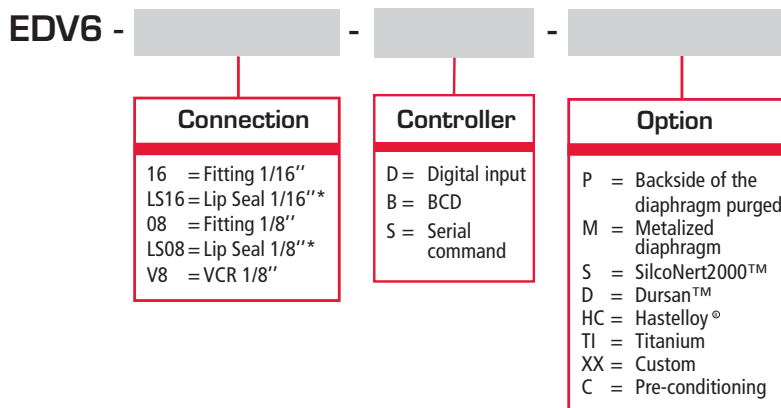

**\*Lip Seal:** Lip Seal fitting is our new patent pending AFP fitting detail. This reduces the dead volume, eliminates the rotation of the ferrule and improves the sealing resulting in an improved connection for valve and fitting. This is very beneficial for any analytical high sensitivity instrumentation. Sealing integrity of a VCR fitting with the flexibility of a compression fitting. Please refer to Design Report 3 (DR-3) in the Analytical Flow Product Cookbook.

\*Patent Pending

### Option

- P** = Backside of the diaphragm purged with extra purge ports on the sealing plate.
- M** = Metalized diaphragm.
- I** = Inline; this allows the possibility to put few valves in series.
- S** = SilcoNert 2000™ The ultimate passivation of treated surfaces. A required treatment for metal components when analyzing for parts-per-billion levels of organo-sulfur compounds & mercury. Greatly reduce moisture contamination, improve system performance and eliminates surface adsorption of active compounds on steel.
- D** = Dursan™ is a coating designed to improve the inertness, hardness, and corrosion resistance of stainless steel. Ideal for sulfur, H<sub>2</sub>S, mercaptan, ammonia and mercury sampling.
- C** = Pre-conditioning; this allows the elimination of atmospheric contaminants from the wetted internal surface.
- HC** = Valve Cap made of Hastelloy®.
- TI** = Valve Cap made of Titanium.
- XX** = Custom request.

**DIMENSION : Refer to website [www.afproducts.ca](http://www.afproducts.ca)**

## CLEANING PROCESS

Please refer to our web site for AFPC-2 i.e. AFP cleaning procedure for O2 compatibility.

## LEAK TESTING

Leak rates are verified at maximum operation conditions. See engineering note EN-01 for more information, available on our website. Verified on a VARIAN™ helium leak mass spectrometer detector and on AFP® proprietary online leak detection system.

### WARNING: NOT TO BE USED IN LIFE SUPPORT EQUIPMENT WITHOUT FORMAL AGREEMENT OF AFP®.

Based on a specific valve configuration and working condition, warranty period and valve maintenance procedure (i.e. part replacement) are different. Please refer to Analytical Flow Products® specific valve documentation for more information.

It is still the responsibility of the user to make sure that the selected valve configuration is safe and reliable for his application.

Analytical Flow Products engineering team will do their best to help customers for any application that may require custom modification. Analytical Flow Products will be please to supply demonstration parts to qualified OEMs.

\*SEE WEBSITE FOR WARRANTY AND DISCLAIMER NOTICE. PRODUCT SPECIFICATION MAY CHANGE WITHOUT NOTICE, ASK FOR UPTODATE NOTIFICATION.

AFP® is a trademark of Analytical Flow Products Company  
Teflon® is a registered trademark of Dupont Company  
Peek™ is a trademark of Victrex Manufacturing Limited.

Varian™ is a registered trademark under license to Varian, Inc.  
SilcoNert 2000™ and Dursan™ is a trademark of SilcoTek corporation  
Hastelloy® is a registered trademark of Haynes International inc.

## APPLICATION EXAMPLES

EXAMPLE WITH THREE DV3.

### LEGEND:

C: INDICATE THE COMMON PORT

● VALVE PLUNGER DOWN, CLOSING THE PORT

○ VALVE PLUNGER UP, OPENING THE PORT

■ FIGURE 2A

### Step 1 - Sample isolated

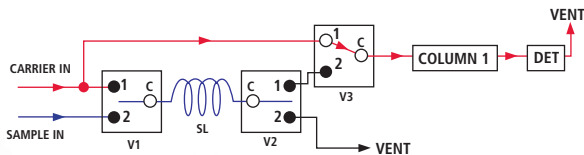

■ FIGURE 2B

### Step 2 - Sample injection into a simple column configuration with sample loop pressurization to carrier pressure

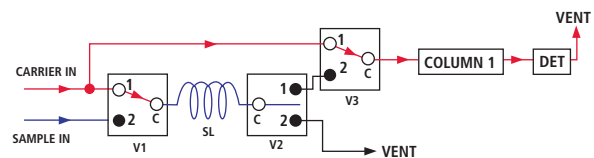

■ FIGURE 2C

### Step 3 - Sample injection into a simple column configuration with pressurized sampling loop injection

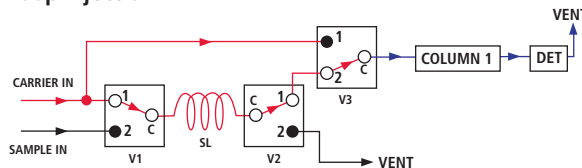







Analytical Flow Products

DV-SERIES

## SHORT TUTORIAL AND TECHNICAL NOTE ON THE DV-SERIES



# DV3-SERIES

A DEEPER STEP INTO INNOVATION



VCR 1/8"



Standard

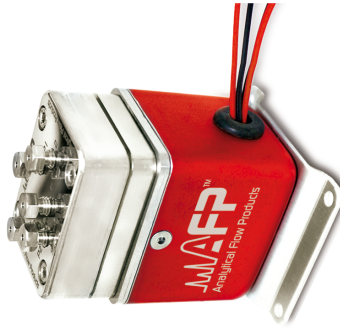

Electronic actuation



Purge sealing plate



Peek head

## Instrumentation and sampling:

- ✓ Makes easier the task of designing complex system configurations

## Analytical / Chromatographic:

- ✓ Allows higher pressure operation for sample and carrier gas
- ✓ Allows unique sample injection method that eliminates column head pressure and flow upset
- ✓ Common conventional configuration like heartcut, backflush, column or sampling loop selection
- ✓ Pneumatic and intelligent electronic actuator



**BASIC CONCEPT**

**Flow Path**

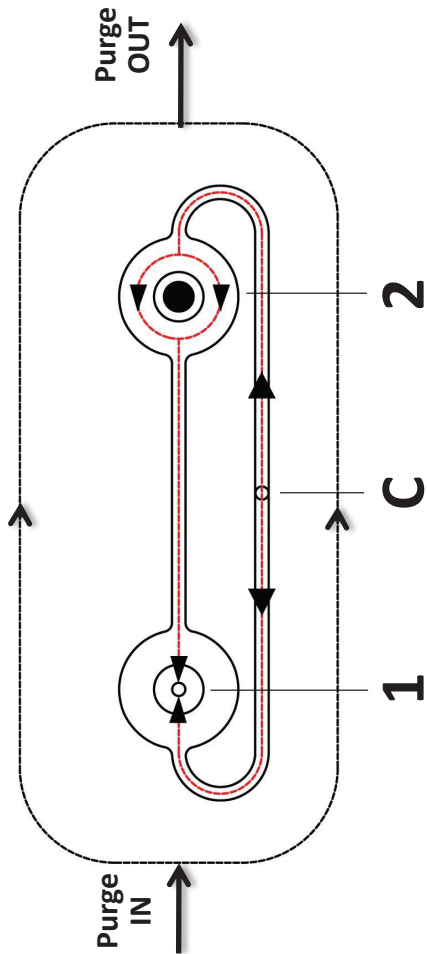

- ✓ No dead volume effect, continuous sweeping action
- ✓ Purging/Sealing groove design, eliminates inboard/outboard leakage.

**Equivalent schematic**

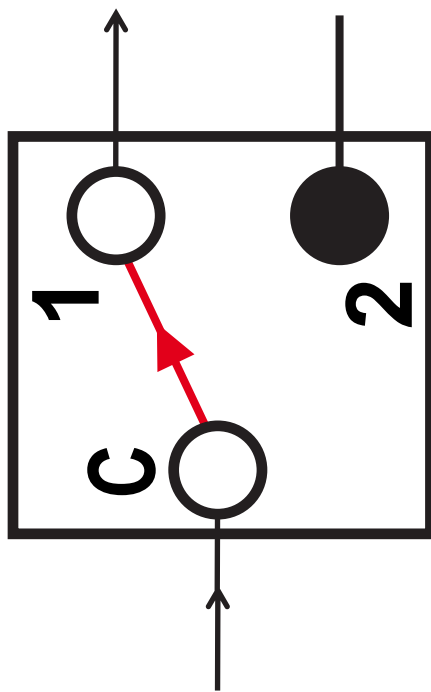

- ✓ Positive port shut off
- ✓ Independent port control
- ✓ Multiple configurations

**POSITIVE PORT SHUT-OFF**



Acts like a standard 1/16" union



PORT CLOSED

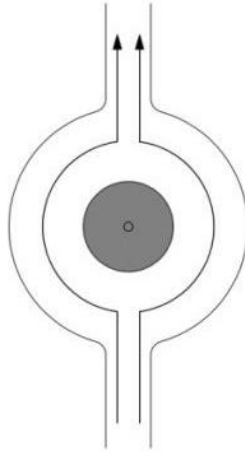

PORT OPEN

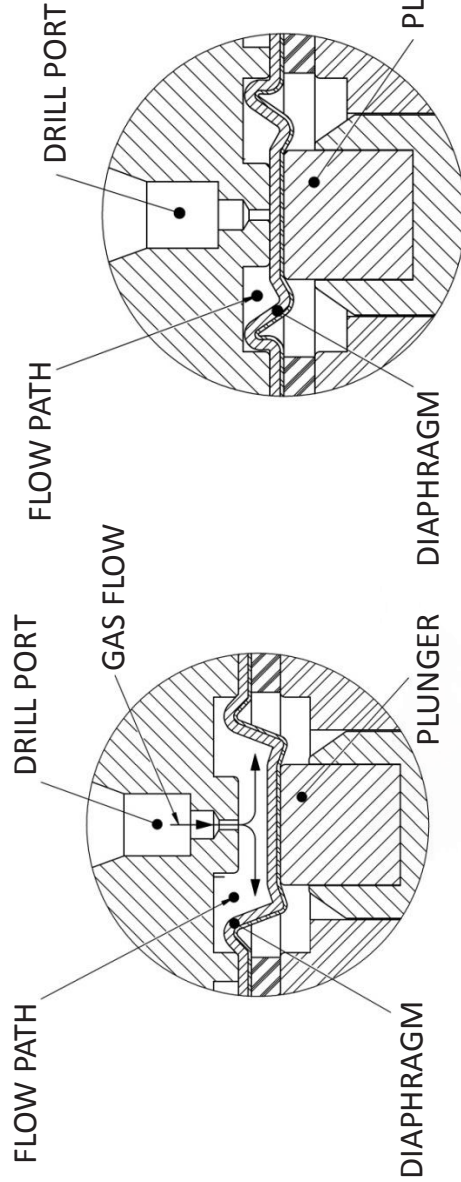
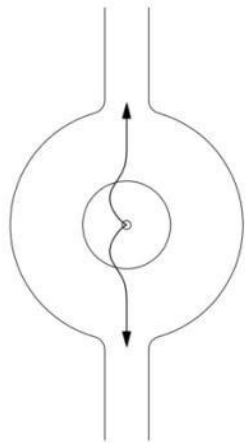



# EXAMPLE OF DIAPHRAGM CONFIGURATION

**Diaphragm:**



**Polyimide + Metal deposition**



**Metal**



**Use with**

**Polyimide**



**Soft seat configuration**

# EXAMPLE OF ACTUATOR CONFIGURATION

**Actuation:**

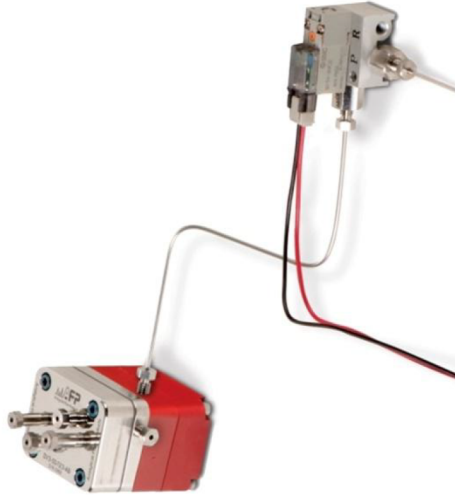

**Actuator using 1 solenoid**

**(Break before make switching mode)**

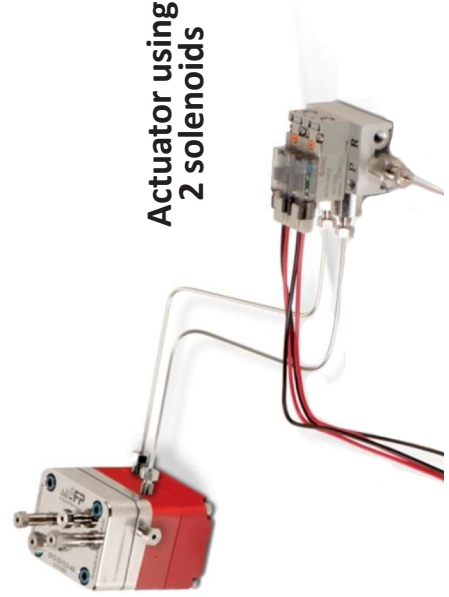

**Actuator using 2 solenoids**

**OPTIONAL PURGING CONFIGURATION**



**Sealing Plate**

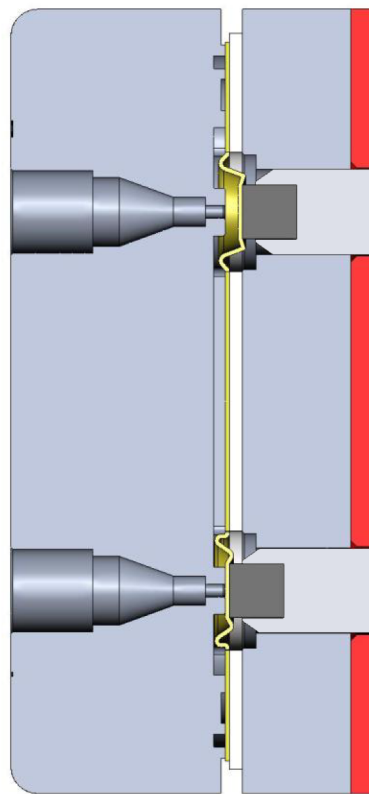

**Standard sealing plate**

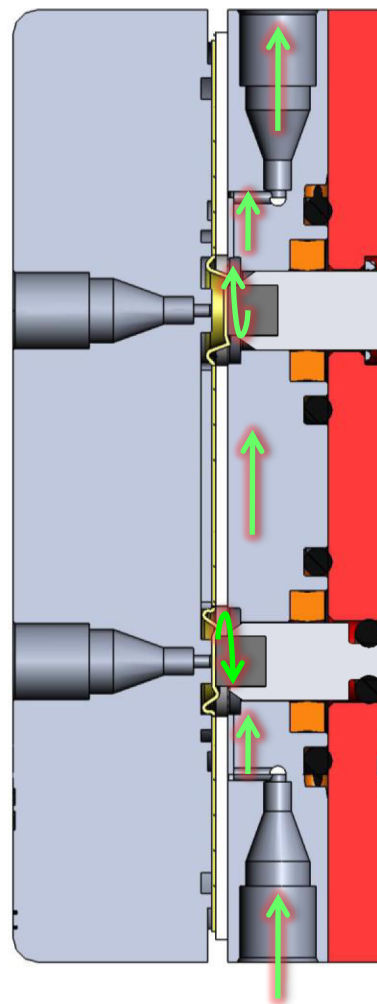

**Purging / Pressurized sealing plate**

# DV6-SERIES



**DV6-1-16-T**  
**Purging Flow Path**

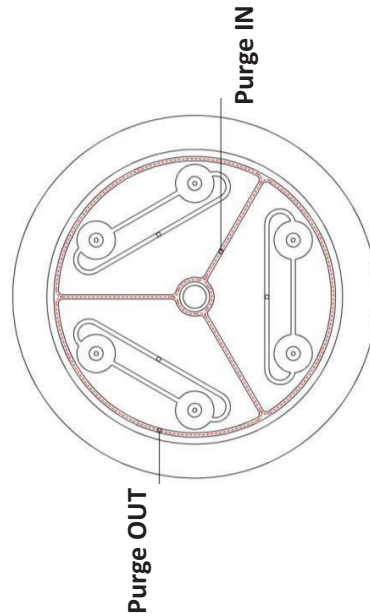

- ✓ Simply three DV-3 cells, embedded on the same substrate to provide a 6 port valve that mimics a standard 6 port GC valve.
- ✓ All DV3 configurations are available with the DV6

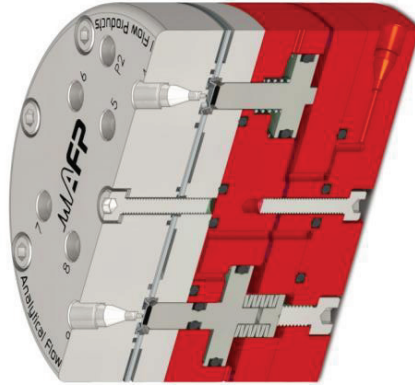

**Purging/Sealing groove**

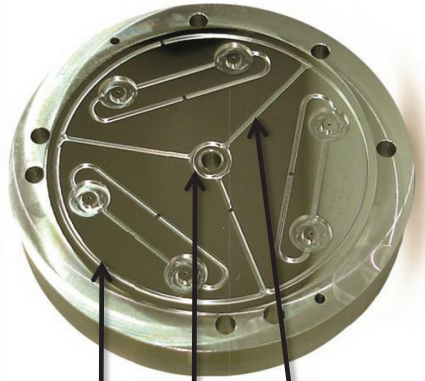

Outer purging groove

Inner purging groove

Radial purging groove

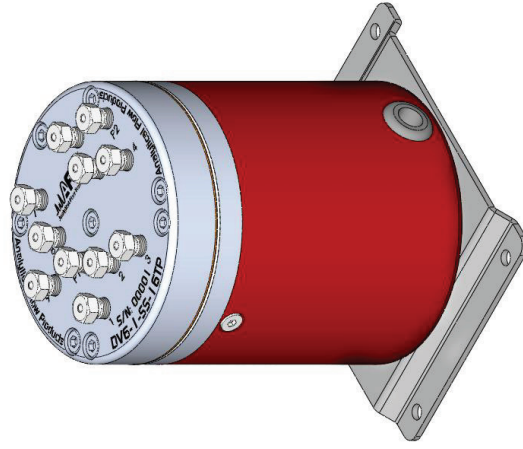

**EDV6-16-S**



# DVS-SERIES



DVS-4, ON/OFF configuration

EDVS-4,  
Sample By-Pass  
configuration

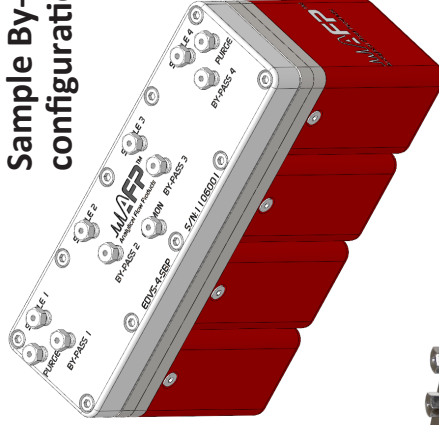

DVS-4 with 1/8" VCR fittings

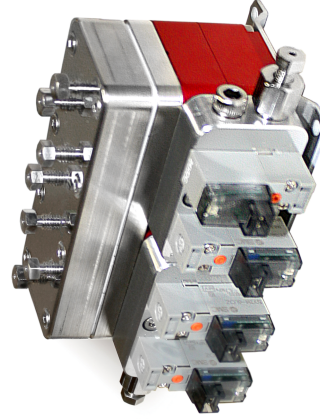

DVS-4 with Bolt-on solenoid manifold

# DVS-SERIES

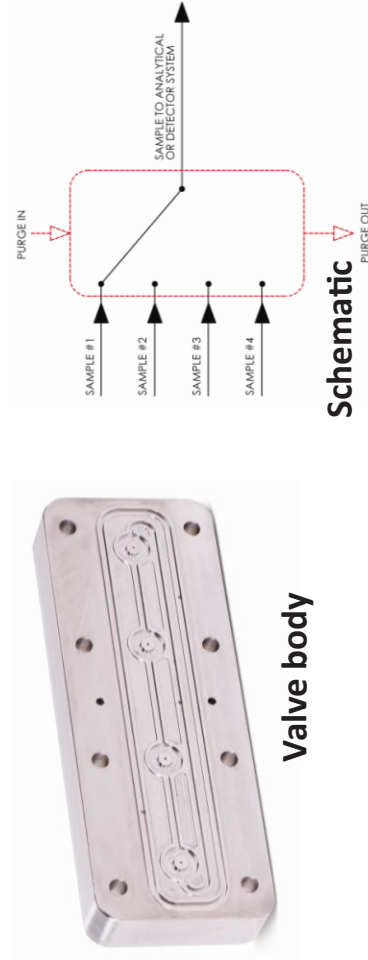

Valve body

Schematic

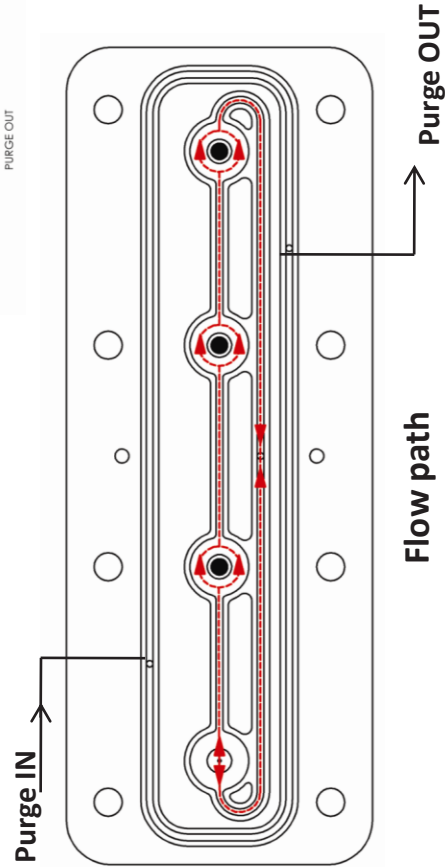

Flow path

- Sample stream selection system made easy
- Could be used in GC for various components selection
- No dead volume effects due to continuous sweeping action. Allows fast system recovery.
- Purge design
- Available in 3, 4, 6, 8 ports.
- Multiple configurations
- Fail/Safe mode selection



# IN-LINE OPTION, POSSIBLE CONFIGURATIONS

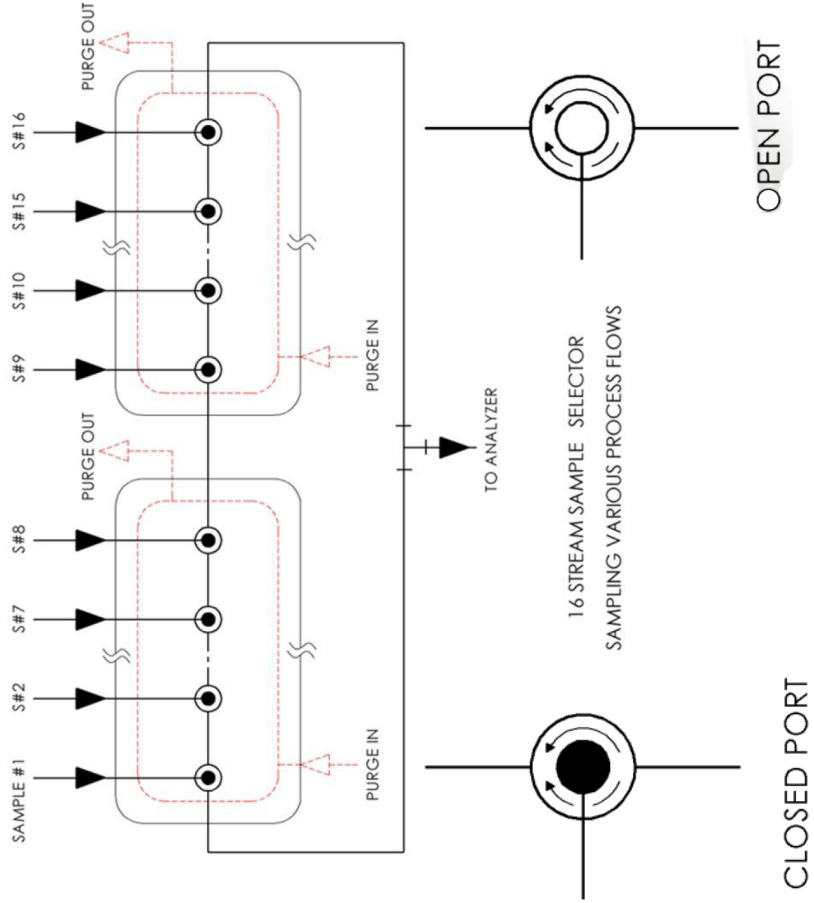
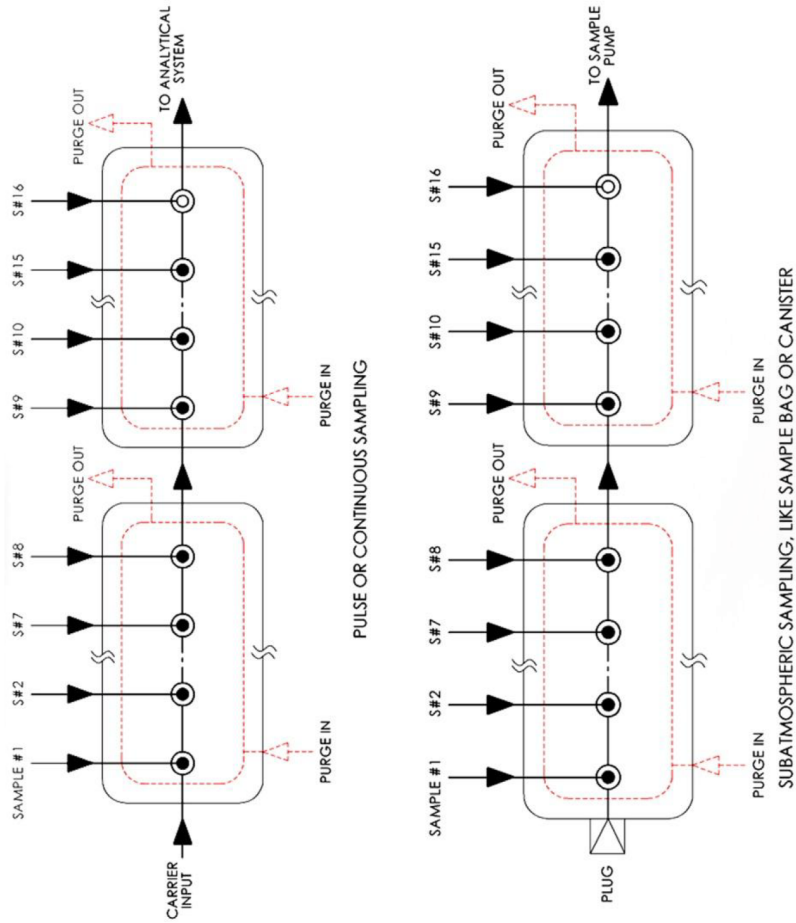



233, Jalbert St. W., Thetford Mines, QC, Canada G6G 7W1  
Phone: 418.338.0004 Fax: 418.338.2500  
Email: [info@afproducts.ca](mailto:info@afproducts.ca)

[www.afproducts.ca](http://www.afproducts.ca)