

Rotary Vane Vacuum Pumps

WH-4SN/WH-8SN/WH-12SN



English Operating Manual

WIGGENS labortechnik GmbH
Mühsamstrasse 3610249 Berlin Germany

Fon: +49 30 42105470 E-Mail: info@chemvak.com
Fax: +49 30 42105971 Web: www.chemvak.com

ChemVac

Rotary Vane Vacuum Pumps

WH-4SN / WH-8SN / WH-12SN

Congratulations!

You have made an excellent choice.

WIGGENS wants to thank you for the trust you have placed in us.

This operating manual has been designed to help you gain an understanding of the operation and possible applications of our CSC series vacuum pumps. For optimal utilization of all functions, we recommend that you thoroughly study this manual prior to beginning any operation.

The WIGGENS Quality Management System



ISO 9001

Certificate Registration No. 01 100084841

Unpacking and Inspection

Unpack the pump and accessories and inspect them for possible transport damage. Damage should be reported to the responsible carrier, railway, or postal authority, and a damage report should be requested. These instructions must be followed fully for us to guarantee our full support of your claim for protecting against loss from concealed damage. The form required for filing such a claim will be provided by the carrier.

Printed in Germany

Changes without prior notification reserved

Important: Keep the operating manual for future use

CONTENTS

1. GENERAL DATA	4
2. VACUUM PUMP DATA.....	4
2.1 OPERATION	4
2.2 APPLICATION	4
2.3 COMPONENTS AND DIMENSIONS.....	5
2.4 TECHNICAL CHARACTERISTICS	6
3. TRANSPORT	6
4. INSTRUCTIONS FOR THE STARTING UP	7
4.1 LOCATION	7
4.2 INTAKE PORT CONNECTION.....	7
4.3. OUTLET PORT	7
4.4. ELECTRICAL CONNECTION	7
4.5 STARTING UP	8
4.6 SWITCHING OFF.....	8
4.7 STORAGE.....	8
4.8 GAS BALLAST OPERATION	8
5. MAINTENANCE INSTRUCTIONS	9
5.1 OIL STATE CONTROL	9
5.2 OIL CHANGING	9
6. CLEANING INSTRUCTIONS	10
7. PUMP ACCESSORIES	10
7.1 ELECTROVALVE	10
7.2 MANUAL VALVE	10
7.3 VACUUM GAUGE VALVE	11
8. WH-4SN EXPLODED VIEW.....	13
9. WH-8SN/12SN EXPLOTED VIEW	14
10. WH SPARE PARTS LIST.....	15
11. TROUBLESHOOTING.....	17
11.1 THE PUMP DOES NOT REACH THE ULTIMATE VACUUM.....	17
11.2 THE MOTOR STOPS	17
11.3 THE PUMP HEATS TOO MUCH	18
11.4 OIL MIST ESCAPES THROUGH OUTLET PORT.....	18
12. WARRANTY.....	18
13. PRODUCT LIABILITY	18

1. GENERAL DATA

These Operating Instructions are valid for the following vacuum pumps:

WH-4SN

WH-8SN

WH-12SN

WARNING

- These operating instructions must be read thoroughly and understood before starting up the vacuum pump.
- Follow all the safety measures given in this manual.
- These vacuum pumps are only to be operated by qualified personnel.
- WH vacuum pumps are supplied with the oil unfilled. Do not start up the pumps without first adding oil (a bottle of oil is supplied with each pump).
- Any use or application of the pump not according to the recommendations stated in this manual might result in a dangerous situation and void the manufacturer's warranty.

2. VACUUM PUMP DATA

2.1 OPERATION

In the WH models, the pump has two stages. The first stage outlet port takes the gases towards the second stage suction point where the new cycle begins. In the second chamber or stage the gas is compressed again until it lifts the valve and is exhausted through the outlet port. This process allows a high level of vacuum.

2.2 APPLICATION

This pump is applicable to medium-high vacuum between atmospheric pressure and the ultimate vacuum, on containers filled with air, gases or mixtures of dry, half- moisturised or moisturised gasses. These pumps are specially designed to be use for air conditioning and refrigeration systems using CFCs, HCFCs and HFCs in conjunction with mineral oil, ester oil, alkylbenzene oil, and PAG oil as lubricants.

Depending on the refrigerant gas type, you have to use the appropriate inlet port to connect the pump to the air conditioning system. Follow the system manufacturer's directions for proper evacuation.

Use separate manifolds and hoses for R-134a systems. Cross-contamination with other refrigerant types will cause severe damage to the A/C system and to service tools and equipment. Do not mix refrigerant types through a system or in the same container.

WARNING

- Never aspirate solid particles or corrosive gasses, unless the pump has the appropriate filter or condenser.
- The pump is design to be use for air conditioning and refrigeration systems using CFCs, HCFCs and HFCs in conjunction with mineral oil, ester oil, alkylbenzene oil, and PAG oil as lubricants. Don't use with ammonia or lithium bromide systems. Not usable with flammable refrigerants.
- Always wear safety goggles when working with refrigerants. Contact with refrigerants can cause eye injury.

2.3 COMPONENTS AND DIMENSIONS

<p>WH-4SN</p> 	<p>WH-8SN/12SN</p> 	<p>IDENTIFICACION DE PARTES</p> <ol style="list-style-type: none"> 1. Electric motor 2. Gas ballast port 3. Oil filling port 4. Intake port 5. Expulsion 6. Oil drain port 7. Oil level glass
--	---	---

Figure 1: Vacuum Pump WH

2.4 TECHNICAL CHARACTERISTICS

	UNIT	WH-4SN	WH-8SN	WH-12SN
Nr. of stages		2	2	2
Nominal flow rate (50/60Hz)	Cfm	1.75/2.1	3.5/4.2	5.2/6.3
Ultimate partial pressure without gas ballast (*)	Microns	25	25	25
Oil filling capacity	oz	10.6	19.4	17.6
Motor consumption power (50/60Hz)	Hp	0.54	0.5	0.5
Rotation speed (at 50/60 Hz)	Rpm	2800/3400	2800/3500	2900/3500
Noise level (50Hz)	Db(A)	66	66	66
Weight	Lbs	15	26.5	27.5
Minimum and maximum room T°	°F	41/104	41/104	41/104

* According to PNEUROP

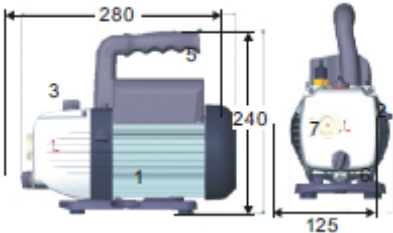
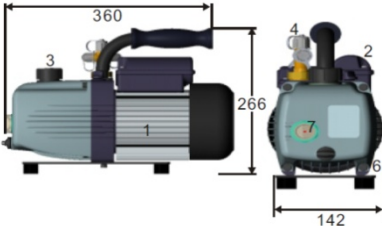
3. TRANSPORT

The pump is supplied in an individual package, with a bottle of oil and this instruction manual. An arrow marks on the packaging box indicates the proper position of the box during storage and transport.

The intake port is protected with a protection stopper, which prevents the introduction of solid or foreign particles inside the vacuum pump. In the models WH-4S/12S, the outlet port is contained in the fluid-filling cap.

4. INSTRUCTIONS FOR THE STARTING UP

4.1 LOCATION

No special assembling is r

equired for the right operation of the pump. It must be on the top of a flat horizontal surface so it rests on its supporting base plate.

Adequate ventilation in the location area is needed to avoid an overheat condition in the vacuum pump.

WARNING

- Do not remove the pump when it is plugged into the power supply. Unplug the pump before moving it.

4.2 INTAKE PORT CONNECTION

WARNING

- Use the correct racord for the inlet port:

WH-4SN: 1/4 SAE (7/16 20 UNF); 5/16 SAE (1/2 20 UNF); 3/8 SAE (5/8 18 UNF)

WH-8SN: 1/4 SAE (7/16 20 UNF); 5/16 SAE (1/2 20 UNF); 3/8 SAE (5/8 18 UNF)

WH-12SN: 1/4 SAE (7/16 20 UNF); 5/16 SAE (1/2 20 UNF); 3/8 SAE (5/8 18 UNF)

-Use the correct connection.

-The intake pressure should not be higher than the atmospheric pressure.

-Vacuum gauge version 1/4 SAE outlet is canceled.

4.3. OUTLET PORT

WARNING

-Check that the outlet cap is not closed or clogged before starting the vacuum pump.

4.4. ELECTRICAL CONNECTION

The pump is supplied with a single-phase motor.

WARNING

- Before connecting the vacuum pump, check that all the voltage and the frequency of the outlet are those indicated in the characteristic plate of the motor.
- In the event of a power cut or a failure, turn off the pump.
- The plant or machine where the pump is connected must comply with the safety rules prevailing in every country.

4.5 STARTING UP

- Depending on the temperature in the work area it is recommended to use vacuum oils in the following ranks:
AV 20: between 5 and 30 of temperature, for general applications.
AV 30: between 15 and 40 of temperature, to be used at high temperature and high vacuum level requirements.

Before starting up the vacuum pump, verify that:

- The start switch is in OFF (0) position,
- The exhaust is clogged.
- The oil level is the correct.

Once these points have been checked, start up the vacuum pump by switching the power switch to the ON (I) position and check that is always connected to a vessel. Do not leave it on with the intake port free (Fig. 1, num. 4).

4.6 SWITCHING OFF

To stop the pump, just turn the general pump into the OFF position.

4.7 STORAGE

Never leave the pump off for a long time without having previously changed the oil. After finishing working with the vacuum pump, place the protection cap in the pump inlet.

4.8 GAS BALLAST OPERATION

The partial aspiration of condensing gasses is possible thanks to the gas ballast valve operation. Before beginning to draw a vacuum, the pump must work with the intake port closed until it reaches the working temperature; otherwise vapor may condense inside the pump.

After the operation we recommend letting the pump work for a few minutes with the gas ballast valve open and the intake port closed. This way the vapor condensed in the oil is removed.

The operation of the valve of gas ballast open normally causes that the level of noise and the vapors of oils escapes increase.

If the period of operation in aspiration of condensable vapors is long, we recommend changing the oil frequently. When the pressure of the water vapor removed is higher than the water vapor tolerance of the pump, install a vapor condenser first.

Although only aspire air due to the possible humidity that can exist the gas ballast valve should be opened during the first minutes of the pump operation.

Do not take out completely the open and/or closure gas ballast valve while it is working. Oil drops may fall.

5. MAINTENANCE INSTRUCTIONS

WARNING

- Unplug the pump before start any maintenance operations.
- Depending on the nature of the gas removed or the process where the operation is performed, the pump or the oil may give off noxious gasses. Therefore, adequate preventive or personal protection measures must be taken before any maintenance operations.

Observe the prevailing environmental protection norms and regulations concerning disposal and refuse of used oil.

5.1 OIL STATE CONTROL

Oil is usually clear and transparent, but this doesn't mean that if the oil color darkens the properties have disappeared. The only way to fix the oil's properties is doing a limit vacuum test using an electronic vacuum gauge.

5.2 OIL CHANGING

You should change the oil with the pump shut off but at service temperature (hot).

To empty dirty oil, unscrew the bottom outlet plug and drain when no more oil comes out,

run the pump for a few seconds and then shut off.

Screw on the outlet plug, and fill the pump with new oil through the filling port until the oil level is up to half the capacity of the oil level glass.

5.3 OIL TYPES

The oils to be used are:

-AV-20 & AV-30: Mineral oils for general applications in industry and laboratories and with refrigerants R-12/22/502.

-CHEMOIL-500: Oil for high temperature applications and with refrigerants R-134-A and R-404/A.

-WETOIL-8R: Oil for use in high quantity water vapor removal.

For other uses, contact our Service Department.

The pump oil capacity is given in paragraph 2.4, Technical Characteristics.

6. CLEANING INSTRUCTIONS

Clean the exterior surface with water and soap or products that cannot damage the plastic parts. We recommend a degreaser to clean the pump. The internal body of the pump is cleaned by pouring solvent through the intake port and turning the rotor by hand. Next, drain the solvent used. Do the final drying with compressed air.

7. PUMP ACCESSORIES

The pump can be supplied with three types of accessories mounted at the inlet of the pump, they are:

7.1 ELECTROVALVE

Electrically actuated valve, ensures the isolation of the vacuum circuit and assists in preventing its contamination. (No 5, Figure 2)

7.2 MANUAL VALVE

Has the same function as the solenoid valve but is actuated manually.

7.3 VACUUM GAUGE VALVE

Provides a visual indication of the pressure in the circuit.

Note: these three accessories can be supplied separately. To make easy the assembly by the user it includes a plane and an electric diagram (in electrovalve).

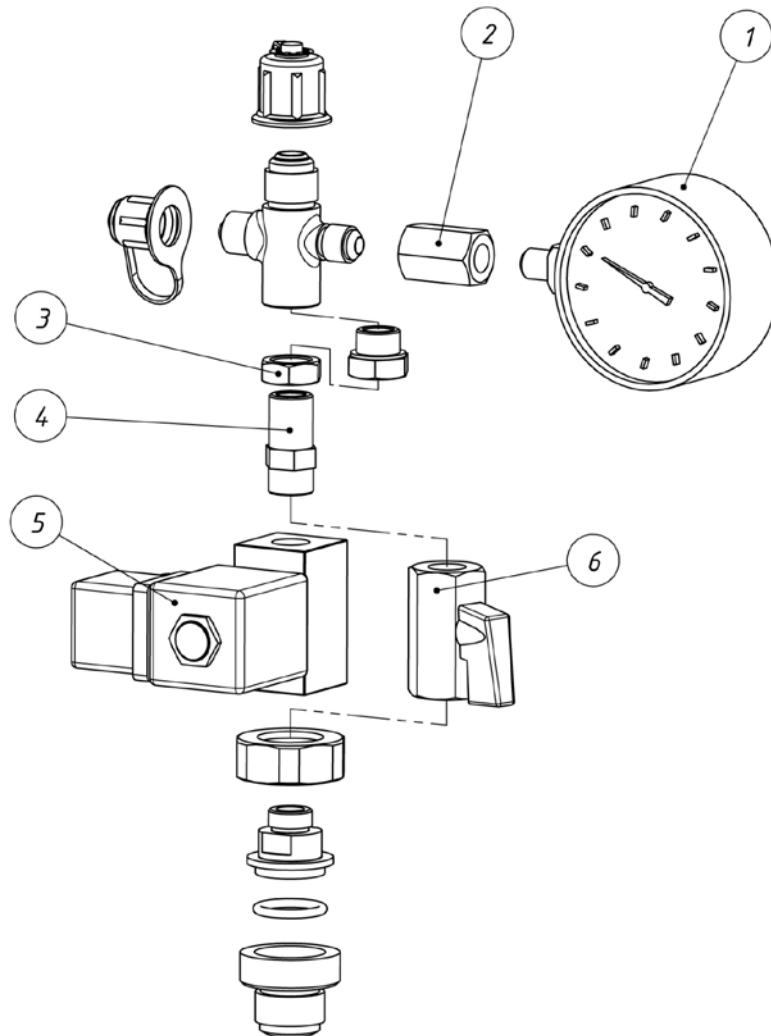

N°	ACCESORIES	CHEMVAK CODE		
		WH-4SN	WH-8SN	WH-12SN
1	Vacuum gauge	80046	80046	80046
2	Adaptor	39550	39550	39550
3	Gas nut	40369	70590	70590
4	Coupling	19704	23882	23882
5	Electrovalve	19749	6066	6066
6	Manual valve	80277	22230	22230

Figure 2: Pump accessories

8. WH-4SN EXPLODED VIEW

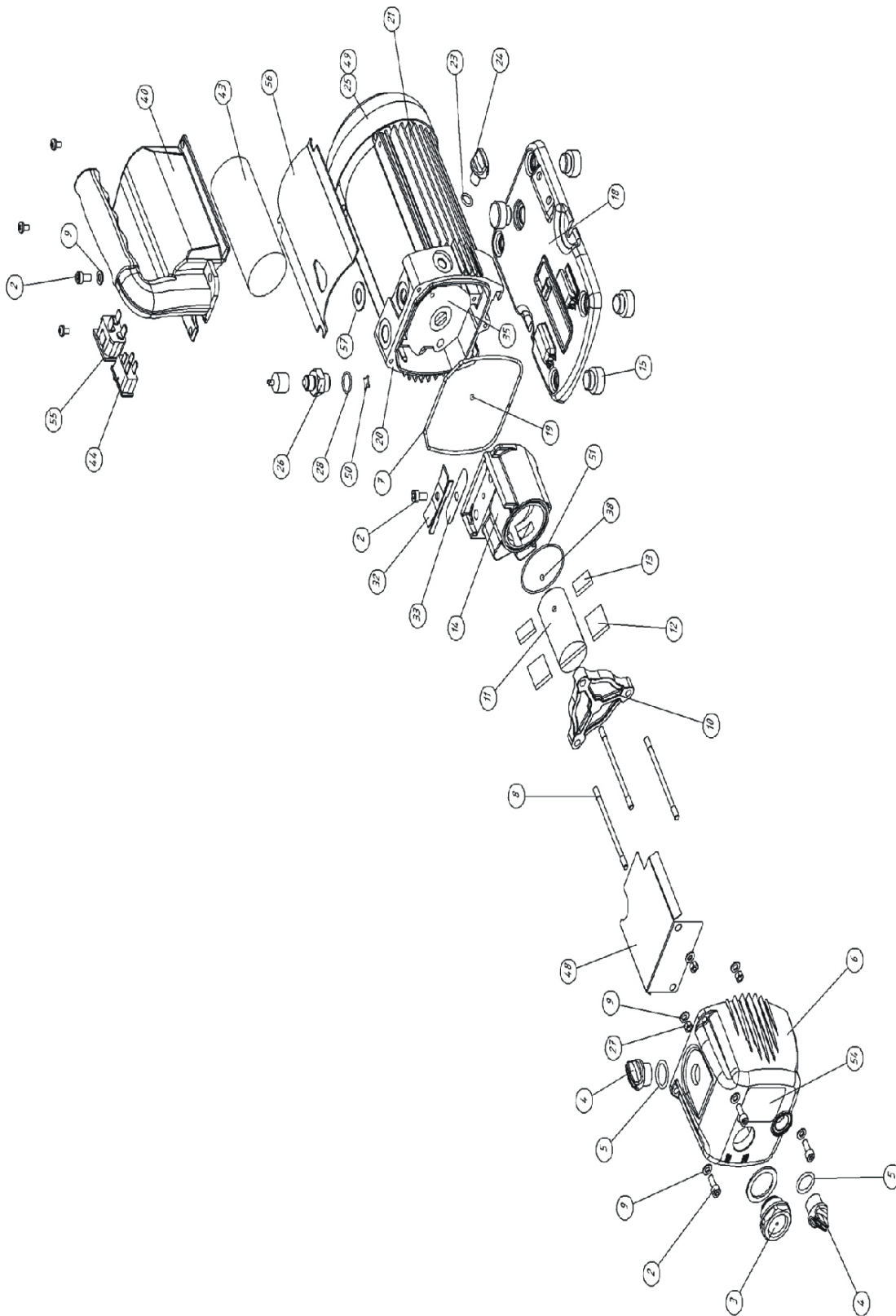

9. WH-8SN/12SN EXPLODED VIEW

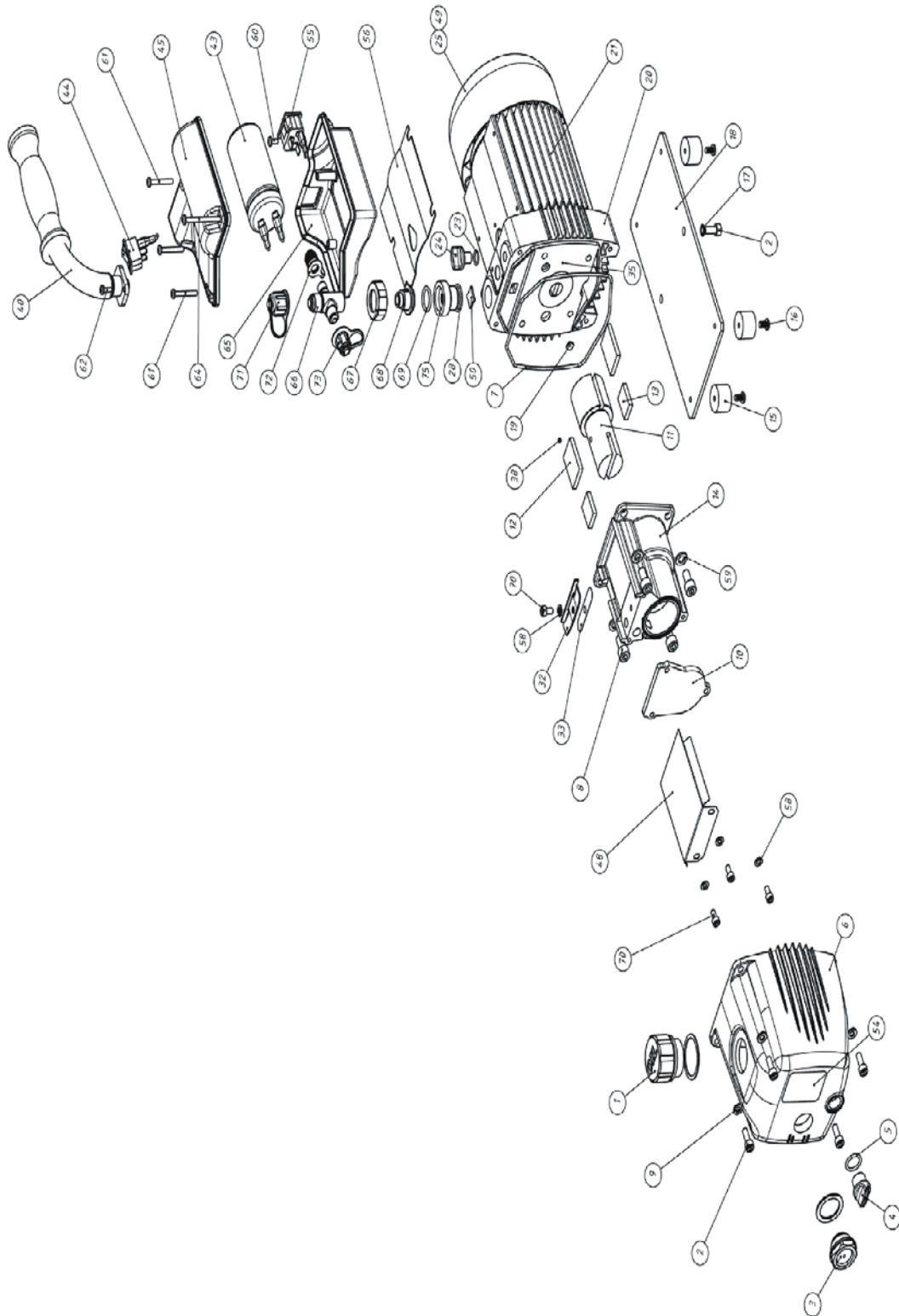

10.WH SPARE PARTS LIST

ITEM	DESCRIPTION (WH-4SN/8SN/12SN)	QUANTITY	
		WH-4SN	WH-8/12SN
1	Exhaust plug	-	1
2	Bolt DIN 912 (M5x12/M6x15/M6x15)	4	6
3	Oil level window	1	1
4	Drain plug	2	1
5	O'ring (φ16x2,5)	2	1
6	Oil case	1	1
7	Gasket oil case 1	1	1
8	Screw (M5x81/M8x15)	3	4
9	Washer DIN 125 (M5/M6)	7	4
10	Plate	1	1
11	Rotor	1	1
12	Vane first stage	2	2
13	Vane second stage	2	2
14	Body	1	1
15	Silent bloc	5-	4
16	Bolt DIN 7981-BZ	-	4
17	Washer DIN 912 M6	1	5
18	Base plate	1	1
19	Inlet gas ballast valve	1	1
20	Mounting motor	1	1
21	Motor 230V 50/60 Hz	1	1
23	O'ring (φ9,25x1,78)	1	1
24	Gas ballast	1	1
25	Electrical fan cover	3	1
26	Inlet port (¼SAE)	1	1-

27	Nut DIN 934 Fe M5 8G Zn	1	1
28	O'ring (ϕ 13x1,5/ ϕ 22x2/ ϕ 22x2)	1	1
32	Retainer valve	1	1
33	Valve	1-	1
35	Shaft seal (AS 14x28x7/AS 17x35x7)	1	1
38	Steel ball ϕ 4	1	1
40	Handle	1	1
43	Condenser	1	1
44	Switch	3	1
45	Electrical motor box cover	7	1
46	Cable	1	1
48	Oil deflector	2	1
49	Motor's fan	2	1-
50	Anti suck back valve	1	1
51	O'ring (ϕ 47x1,5)	5-	1
52	Major kit	-	1
53	Gaskets kit	1	1
54	Vacuum pump characteristic plate	1	2
55	Base snap in	1	1
56	Motor gasket	1	1-
57	Plane gasket 11x21	1-	4
58	Washer DIN 125 M5 Fe Zn	-	4
59	Washer DIN 127 M8 Fe	-	1
60	Bolt DIN 7981 4,2x9,5 autorr.	-	3
61	Bolt DIN 7981 4,2x32 autorr.	-	2
62	Bolt DIN 7985 Fe M4x12 ZN	-	1
64	Bolt DIN 7981 4,2x50 autorr.	1	1
65	Motor box base WH-8S/12S	-	1
66	Inhalation cross racor	1	1

67	Nut racor 1/2 G	1	1
68	Racor 1/4G	1	1
69	O'ring	1-	4
70	Bolt DIN 912 M5x10 Fe Zn	1	1
71	Nylon cap 3/8 SAE	1	1
72	Nylon cap 1/4 SAE	1	1-
73	Nylon cap 5/16 SAE	1	1
74	Reduction M 1/4 G H 1/8 G	1	1-
75	Anti suck back racor	-	4

11.TROUBLESHOOTING

11.1 THE PUMP DOES NOT REACH THE ULTIMATE VACUUM

POSSIBLE CAUSE:

POSSIBLE CAUSE:	SOLUTION
Leaks	Separate the pump from the rest of the system and measure the ultimate pressure directly at the pump inlet. If the value is correct, the leak must be in the system. If the value is not enough h, check the oil level and add the quantity required (see table 2.4). If the pressure is still low after checking the oil level, check the following points.
Contaminated oil	Empty the oil housing and refill with new oil (see point 5.2).
Gas Ballast open	Make sure that the gas ballast is totally open.

11.2 THE MOTOR STOPS

POSSIBLE	CAUSE:
The thermal protection relay goes off	Wait for the motor to cool (about 10 minutes).

11.3 THE PUMP HEATS TOO MUCH

POSSIBLE	CAUSE:
Pump is located in an area with poor ventilation	Put the pump in a place with the adequate ventilation
Ambient temperature very high	Put the pump in a place with the adequate ventilation. (see point 4.1.).
Mechanical failure caused by dirt or insufficient lubrication	Clean the pump (see point 6).

11.4 OIL MIST ESCAPES THROUGH OUTLET PORT

POSSIBLE	CAUSE:
Leaks	See point 11.1
Gas Ballast open	See point 11.1

12.WARRANTY

We guarantee the perfect functioning of this instrument against defects in material, design, and workmanship, when use under appropriate conditions and in accordance with the instruction manual for a period of **TWO YEARS** from the date of initial shipment.

This warranty covers all parts and components of the instrument except those normally requiring frequent replacement, such as tubing, gasket, O-rings, etc. We will not be liable for any personal injury, improper maintenance, or negligence of accident.

13.PRODUCT LIABILITY

Under no circumstances shall Chemvak be liable for indirect, consequential or otherwise special or unrelated damages of any kind.

Chemvak reserves the right to make technical changes without prior notice.

Email: info@chemvak.com

Web Site: www.chemvak.com

Rotary Vane Vacuum Pumps

WH-8D/WH-17D



English Operating Manual

WIGGENS labortechnik GmbH

Mühsamstrasse 3610249 Berlin Germany

Fon:+49 30 42105470 E-Mail:info@chemvak.com

Fax:+49 30 42105971 Web:www.chemvak.com

ChemVak

Dual-Stage Rotary Vane Vacuum Pumps
WH-8D / WH-17D

Congratulations!

You have made an excellent choice.

WIGGENS wants to thank you for the trust you have placed in us.

This operating manual has been designed to help you gain an understanding of the operation and possible applications of our CSC series vacuum pumps. For optimal utilization of all functions, we recommend that you thoroughly study this manual prior to beginning any operation.

The WIGGENS Quality Management System



ISO 9001

Certificate Registration No. 01 100084841

Unpacking and Inspection

Unpack the pump and accessories and inspect them for possible transport damage. Damage should be reported to the responsible carrier, railway, or postal authority, and a damage report should be requested. These instructions must be followed fully for us to guarantee our full support of your claim for protecting against loss from concealed damage. The form required for filing such a claim will be provided by the carrier.

Printed in Germany

Changes without prior notification reserved

Important: Keep the operating manual for future use

CONTENTS	PAGE
1. Description.....	6
1.1 FUNCTION	6
1.2 SUPPLIED EQUIPMENT	7
1.2.1 pump with single-phase ac motor	8
1.3 ACCESSORIES	8
1.4 TRANSPORTATION	8
1.5 DIMENSION.....	9
1.6 TECHNICAL DATA	10
2. Operation	11
2.1 INSTALLATION AND CONNECTION.....	11
2.2 ELECTRICAL CONNECTIONS.....	12
2.2.1 pump with single-phase ac motor	12
2.2.2 pump with three-phase ac motor	12
2.3 START-UP.....	13
2.4 OPERATION	13
2.4.1 pumping of non-condensable gases and vapours	14
2.4.2 pumping of condensable gases and vapours	14
2.4.3 operation under special climatic and other conditions	15
2.5 SWITCHING OFF	15
2.5.1 putting the pump out of operation	16
3. Maintenance.....	16
3.1 MAINTENANCE INFORMATION/CHECKING THE OIL LEVEL	16
3.1.1 oil level	17
3.1.2 oil condition	17
3.2 OIL CHANGE	18
3.2.1 disposal of used pump materials	19
3.3 CLEANING THE DIRT TRAP	20
3.4 MAINTAINING THE OIL FILTER.....	20
3.5 MAINTAINING THE GAS BALLAST VALVE.....	20
3.6 MAINTENANCE PLAN (RECOMMENDATION)	20
4. Trouble Shooting.....	23
5. Warranty	25
6. Product Liability	25

ALL REPAIR AND SERVICE WORK SHOULD BE DONE BY A CHEMVAK SERVICE CENTER NEXT TO YOU. IN SUCH A CASE,

Chemvak will provide a replacement pump.



The Chemvak is supplied with oil to be added for operation.

We recommend that you read these Operating Instructions carefully so as to ensure optimum operating conditions right from the start.

The references to diagrams, e.g.(1/2) consist of the Fig. No. and the Item No. in that order
If a pump is returned to Chemvak, indicate whether the pump is free of substances damaging to health or whether it is contaminated.

If it is contaminated also indicate the nature of the hazard. Chemvak must return any pumps without a “Declaration of Contamination“ to the sender’s address.



Warning

Indicates procedures that must be strictly observed to prevent hazards to persons.

Caution

Indicates procedures that must strictly be observed to prevent damage to, or destruction of the pump.

General

We reserve the right to modify the design and the specified data. The illustrations are not binding

Important Safety Information

The Chemvak pump is designed for safe and efficient operation when used properly and in accordance with this manual. It is the responsibility of user to carefully read and strictly observe all safety precautions described in this section and throughout the manual.

Address any further safety, operation and/or maintenance questions to your nearest Chemvak office.

Warning Failure to observe following precautions could result In serious Injury!

- Before beginning with any maintenance or service work on the Chemvak disconnect the pump from all power supply.
- Make sure that the gas flow from exhaust port is not blocked or restricted In any way.
- The Chemvak is not suited for operation in the explosion hazard areas. Contact us before planning to use the pump under such circumstance.
- Before starting up for the first time, the motor circuit must be equipped with a suitable protective motor switch.
- The Chemvak is not suitable for pumping of:
 - Combustible and explosive gases or vapours
 - Radioactive and toxic substances
 - Pyrophorous substances
- Under certain ambient conditions the Chemvak may attain a temperature over 80°C. There exists the danger of receiving burns. Note the symbols on the pump pointing to the hazards, and In the case of a hot pump wear the required protective clothing.
- Chemvak is not suitable for pumping oxygen (or other highly reactive gases) at concentration exceeding the concentration in the atmosphere (>21% for oxygen).
- Do not use the pump for applications that produce abrasive or adhesive powders or condensable vapors that can leave adhesive or high viscosity deposits. Please contact Chemvak Sales for selecting the right separator.
- Check the oil level when the pump running.
- The pump must be operated at ambient temperature between 10°C and 40°C. It needs to be ensured that the thermal radiation produced by the pump can be dissipated sufficiently, particularly when built into enclosed system (cabinets), and that a temperature of 40°C is not exceeded.
- Chemvak is not suitable with frequency converter. There is danger of motor burn.

1. Description

1.1 Function

Chemvak pumps are oil-sealed rotary vane pumps. The drive motor, is directly flanged onto the pump cylinder. The pump and motor shafts are directly connected by means of a flexible coupling. A fan mounted on the coupling and the cooling apertures serve to maintain low temperatures around the coupling even under extreme conditions. All bearing points are lubricated slide bearings.

The pump cylinder consists of assembly parts sealed with O-rings. All parts are pin-fitted so as to allow easy disassembly. The inner pump body can easily be dismantled without special tools.

The rotor (1/2), mounted eccentrically in the pump cylinder (1/1), has three radially sliding vanes (1/16) which divide the pump chamber into several compartments. The volume of each changes periodically with the rotation of the rotor.

As a result, gas is sucked in at the intake port (1/7). The gas passes through the dirt trap sieve (1/6), passes the open airing/isolation valve (1/5) and enters the pump chamber. In the pump chamber, the air is passed on and compressed, after the inlet aperture is closed by the vane. At (1/15), oil is sucked into the chamber; it is used, on the one hand, for lubrication and sealing of the space between the chamber wall and the vane head and, on the other, for lubrication and sealing of the vanes (1/16) in the rotor (1/2). The gas compressed in the pump chamber is expelled to the atmosphere through the exhaust valve (1/12). The oil entrained with the compressed gas is trapped in the oil filter (1/11); there the oil is also filtered and freed of mechanical impurities. The admission of secondary air -so-called "gas ballast" - prevents condensation of vapours in the pump chamber. At the beginning of compression, an exactly dosed amount of gas ballast is admitted at (1/14); this ensures the water vapour tolerance stated in the Technical Data. The gas ballast valve is opened and closed by turning the locking cap (1/8). The slap noise of the oil in the pump, which normally occurs when the ultimate pressure is attained, is prevented by also admitting a very small amount of secondary air into the pump chamber at (1/14).

Key to Fig.1

1. Pump cylinder
2. Rotor
3. Pin-fitted
4. Intake channel
5. Airing/ isolation valve
6. Dirt trap
7. Intake port
8. Gas ballast valve cap
9. Exhaust port
10. Secondary air inlet (silencing)
11. Oil filter
12. Exhaust valve
13. Exhaust channel
14. Gas ballast channel
15. Oil injection
16. Vane

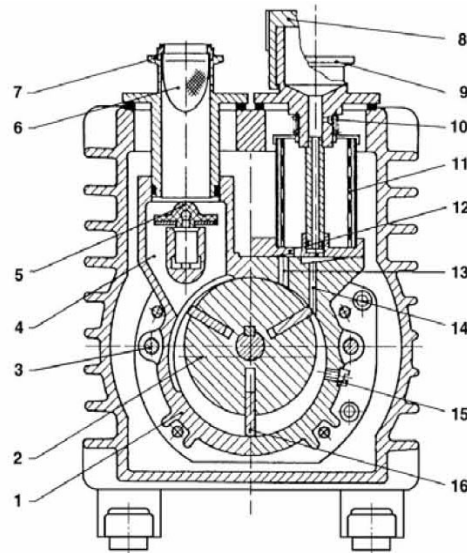

Fig.1 Functional diagram of the pumps

When the pump is stopped, a centrifugal switch on the pump shaft opens a venting pipe which feeds atmospheric air under the piston of the airing/ isolation valve. As a result, the disc of the airing / isolation valves pressed against its seat in the intake port, the line leading to the vacuum vessel is closed and the pump is vented.

The built-in oil-level glass makes it easy to check the oil level. The standard pumps are available with single-phase or three-phase AC motor.

1.2 Supplied Equipment

Upon delivery, the small-flange connection ports of the pump are blanked off.

Two centering rings and two clamping rings each (DN 25 KF) are supplied as standard equipment to connect the intake and discharge lines. One 25 KF, centering ring is including a dirt trap sieve for the intake port.

1.2.1 Pump with Single-Phase AC Motor

The pump is supplied with motor, switch, motor protection switch, mains cable, plug and crane eye.

1.2.2 Pump with Three-Phase AC Motor

The pump is supplied with motor and crane eye.

A switch, motor protection switch, mains cable and plug are not part of the standard equipment.

A switch and motor protection switch can be supplied as extras when ordered.

1.3 Accessories

Order No.

Exhaust filter AF8D/AF17D , DN25KF	900110-1
Replacement filters FE17 (set of 5)	900110-2
Condensate separator AK8/AF17, DN25KF	900110-3
Dust filter FS8/FS17	900110-4

Connection components required to connect the exhaust filter and the condensate separators in each case:

For Chemvak WH-8D/WH-17D

1 Pipe bend, DN25KF	900110-5
1 Centering ring with O-Ring, DN25KF	900110-6
1 Clamping ring, DN25KF	900110-7
Oil N62 1L	900110-8
5L	900110-9

Remarks: Any other request about accessories, please contact us.

1.4 Transportation



Caution

Pumps which are filled with operating agents must only be moved while standing upright. Otherwise oil may escape. Avoid any other orientations during transport.

Warning

Check the pump for the presence of any oil leaks, since there exists the danger that someone may slip on spilt oil.

- When lifting the pump you must make use of the crane eyes or handle the pump for this purpose; also use the recommended type of lifting device.

1.5 Dimension

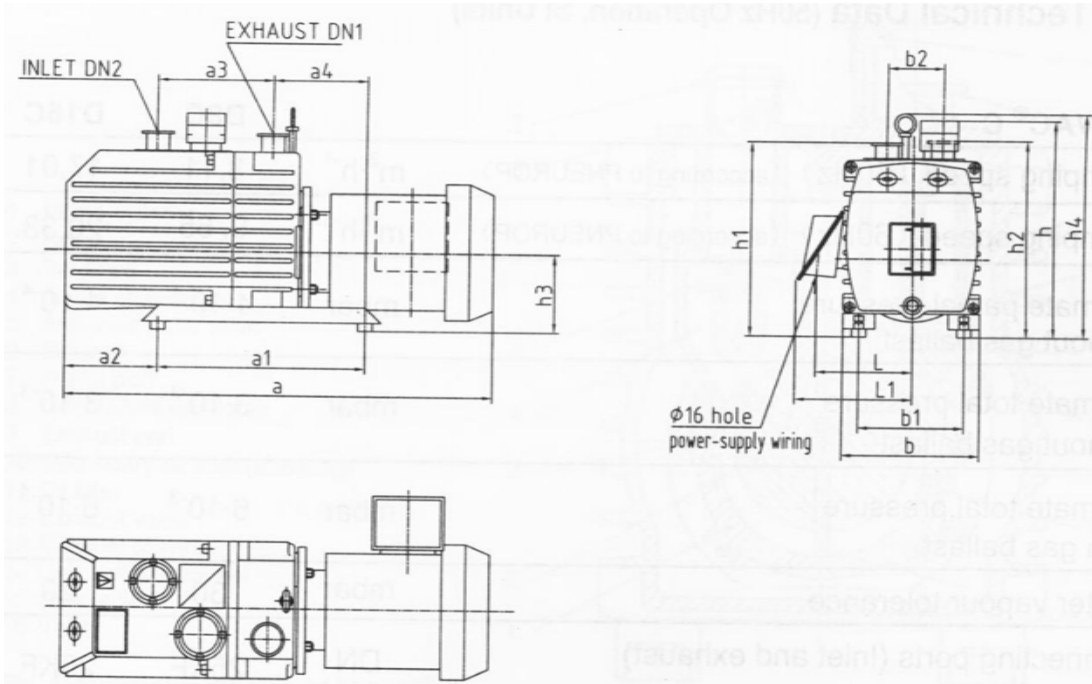

Figure.2 dimension

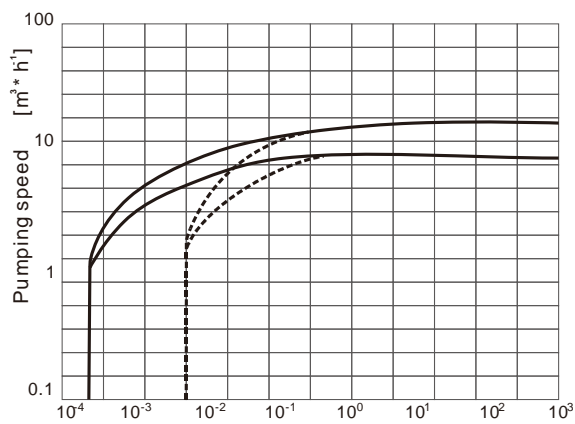

Figure.3 pumping speed (at 50Hz)

Type	DNI	DN2	A1	A2	A3	A4	B	B1	B2	H	H1	H2	H3	H4	L	L1
WH-8D	25KF	25KF	260	75	146	118	173	133	71	272	243	246	100	295	128	160
WH17D	25KF	25KF	260	117	146	118	173	133	71	272	243	246	100	295	128	160

1.6 Technical Data (50Hz Operation, SI Units)

Chemvak		WH-8D	WH-17D
Nominal pumping speed (50Hz)	m ³ ·h ⁻¹	8.11	17.01
Nominal pumping speed (60Hz)	m ³ ·h ⁻¹	9.65	20.33
Ultimate partial pressure without gas ballast	mbar	4·10 ⁻⁴	4·10 ⁻⁴
Ultimate total pressure ¹⁾ without gas ballast	mbar	3·10 ⁻³	3·10 ⁻³
Ultimate total pressure ² with gas ballast	mbar	6·10 ⁻³	6·10 ⁻³
Water vapour tolerance	mbar	30	20
Connecting ports (Inlet and exhaust)	DN (mm)	25KF	25KF
Noise ²⁾ (sound pressure level at 1 m With gas ballast closed / open (50Hz))	dB (A)	54/56	56/58
Oil filling (Capacity) Max / Min	L	1.1/0.7	1.5/1.0
Weight (without oil filling)	Kg	27	31
Ambient temperature (Max / Min)	°C	40/10	40/10
Motor power 220V / 50Hz,	W	550	750
Single-Phase Overall length a ³⁾	mm	471	560
Cat. No.		900111	900112
Motor power 380V 50/60Hz,	W	550	550
three-Phase Overall length a	mm	500	540
Cat. No.		900113	900114

Remarks:

- 1) The values are measured by Capacitance Diaphragm Gauge, If using Priani Gange, the values will be half or a decade higher. The values are defined by pumps with N82 ail.
- 2) The value is for 3 phase motor, will be a little higher for 1 phase motor.
- 3) The "a" value far your reference. it you select other type motor, the "a" value will change a little.

2. Operation

2.1 Installation and connection

Note

Before connecting the Chemvak pumps, remove the transport seals from the connection flange.

When installing the Chemvak pumps, make sure that the connections and controls are readily accessible. The site chosen should allow adequate air circulation to cool the pump. The ambient temperature should not exceed +40°C and not drop below +10°C (see Section 2.4.4).

The pump can be set up on a flat, horizontal surface; it need not be secured to the floor. The cross-section of the connecting lines (intake and discharge lines) should be at least the same size as the connection ports of the pump. If the intake line is too narrow or too long, it reduces the pumping speed. If the discharge line is too narrow, excessive pressure may occur in the pump at high intake pressures; this might damage the shaft seals and cause oil leaks.

For avoiding of overpressure, you can install the exhaust fan at the end of exhaust pipe or use the short wide exhaust pipe.

If the medium pumped contains dust, a filter should at all events be installed

Vacuum-tight connection of the pump is essential so that the pump can attain the ultimate pressure. We shall gladly offer you solutions attuned to your specific needs.

The exhaust line should preferably be installed with a downward slope so as to prevent condensate from flowing back into the pump and contaminating the oil. If the exhaust line has an upward slope, a condensate trap must at all events be installed.

If no exhaust line is connected, it is advisable to fit an exhaust filter.

If several pumps are connected to one exhaust line, ensure an adequate cross-section and a non-return valve at the exhaust of each pump.



Caution

On no account may the pump be operated with a blocked or constricted exhaust line. Make sure before start-up that any blinds or similar shut-off devices in the exhaust line on the pressure side are opened and that the exhaust lines are not obstructed by deposits.

Depending on the type of use of the pump and the medium pumped, please observe the relevant safety rules and specifications.

2.2 Electrical Connections



Warning

Electrical connection work must only be carried out by a skilled electrician in accordance with the applicable safety rules (VDE 0100).

2.2.1 Pump with Single-Phase AC Motor

With this design, the pump can be directly connected by means of the connecting cable and plug to the 220 V AC mains, using a suitable fuse; refer to the current value stated on the name plate of the motor.

The direction of rotation need not be checked as it is fixed. The motor is protected against overloading by a thermal overload switch. After this switch has cut out the motor, the motor is automatically switched back on once it has cooled down.



Warning

If the thermal overload protector shuts off the pump, the motor will restart It self as it cools. That's why the mains plug should be disconnected from the mains before starting with any work on the pump.

2.2.2 Pump with Three-Phase AC Motor

Chemvak pumps with three-phase motor are supplied without accessories for electrical connection.

You must connect the pump using an appropriately rated and a suitably rated motor protection switch. The value set on the motor protection switch must correspond to the current rating

stated on the name plate of the motor.



Caution

After connecting the motor and after every change of connection, check the direction of rotation. To do so, switch on/off the motor immediately and see whether a blank cover is sucked on at the intake port. If not, inter-change two phases of the connection, Observe the direction arrow!

Caution

If the pump runs for too long in the wrong direction, it ejects its oil. There is also the danger of the pin-hole parts and the disc of built-in airing/isolation valve being destroyed. When checking the direction of rotation, it is advisable to cover the intake port with a rag or something similar so as to avoid being squirted with oil.

2.3 Start-up

There are no special rules for initial start-up of Chemvak pumps; they can be started up without special measures, except 3-phase motor, see note below.

Note

On Chemvak pumps with three-phase motor, check the direction of rotation (see Section 2.2.2).

On initial start-up, after prolonged idle periods or after an oil change, the specified ultimate pressure cannot be attained immediately because the oil must first be degassed. This can be done by running up the pump for approx. 30 min. with the intake line closed and the gas ballast valve (4/3) open.

2.4 Operation

These pumps are capable of pumping gases and vapours. Vapours can only be pumped provided the gas ballast valve is open and provided the pump has attained its operating temperature.

Note

The Chemvak pump may be run only briefly at operating pressures over 250 mbar without exhaust filter, 350 mbar with exhaust filter.

If media that must not come into contact with the ambient air are to be pumped, please consult us for our special solutions.

2.4.1 Pumping of Non-Condensable Gases and Vapours

In the presence of excess quantities of permanent gases the pump may be operated without gas ballast, provided the saturation vapour pressure at the operating temperature is not exceeded during compression.

If the composition of the gases which are to be pumped is not known and if the possibility of condensation within the pump can not be excluded, we recommend operation of the pump with the gas ballast valve open in accordance with Section 4.2.

2.4.2 Pumping of Condensable Gases and Vapours

With the gas ballast valve open and when the pump is running at its operating temperature, pure water vapour can be pumped up to 20~40 mbar. When the vapour pressure increases above the permissible level, the vapour will condense in the oil of the pump. In this case we recommend a condenser in the intake line.

When pumping vapours make sure that the gas ballast valve is open and that the pump has been running for at least 30 minutes with the intake line closed and with gas ballast.



Caution

It will be possible to pump vapours up to the permissible limit only after the pump has reached its operating temperature.

During the pumping process vapours may dissolve in the oil of the pump. This impairs the properties of the oil and there is the risk of corrosion within the pump. For this reason the pump must not be switched off immediately after termination of the process. The pump must remain on with the gas ballast valve open and the intake line sealed until all vapours which were dissolved in the oil have been removed.

We strongly recommend that the Chemvak pump be left running for about 30 minutes after termination of the process.

In the case of cyclic or repetitive processes the Chemvak should not be switched off during the breaks between the individual work phases (low energy requirement when running at ultimate pressure). The gas ballast valve should be opened and the intake line should be sealed (through a valve, if possible).

When all vapours have been pumped from a process (drying, for example) the gas ballast valve can be closed to improve the attainable ultimate pressure.

2.4.3 Operation under Special Climatic and Other Conditions

Proper start-up of the Chemvak is ensured ambient temperatures from 10 to 40 °C. At its operating temperature, the surface temperature of the Chemvak (oil sump) may lie between 40 °C and 75 °C, depending on the load. If the temperature is above or below this range owing to the ambient conditions, the operating range of the Chemvak can be adapted by using other oils or motors with other insulation classes. Chemvak -Sales Dept. gladly answer any queries.



warning

Chemvak pumps may attain high surface temperatures.



There is the danger of receiving burns.

There is the danger of scald.

Key to Fig.4

1. Oil fill
2. Intake port
3. Gas ballast valve
4. Exhaust port
5. Mains connection
6. Oil drain
7. Oil level indicator

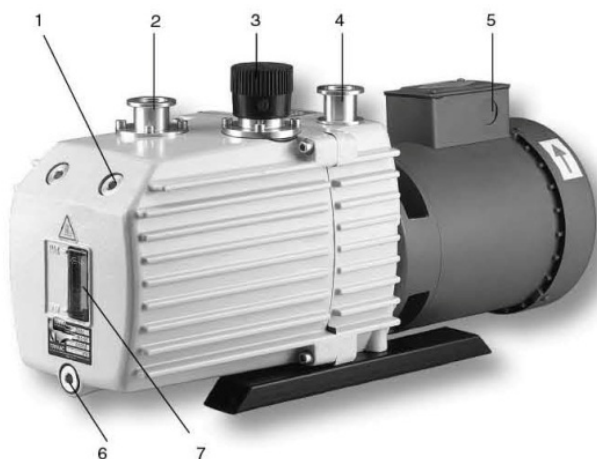

Fig.4 Connections and controls

2.5 Switching Off

Under normal circumstances, the pump merely has to be switched off, without any other action being necessary.

When using the Chemvak in processes with aggressive or corrosive media, it is advisable to let the pump continue to operate even during long non-working intervals (e.g. overnight) with the intake line closed and the gas ballast valve open. This avoids corrosion during idle periods. If the Chemvak is to be put out of operation for a prolonged period after having been used to pump aggressive or corrosive media,

it should at once be thoroughly flushed out and filled with clean oil.

In the pumps intake port there is an airing/isolation valve, which closes the intake port when the pump is switched off, thus maintaining the vacuum in the vessel connected.

When the pump is switched off, a centrifugal switch opens the built-in venting valve. The atmospheric air entering via the venting valve flows under the piston of the airing/isolation valve, thereby closing the intake port, venting the pump and preventing oil suck back.

Closure of the intake port occurs independently of the pump's mode of operation, i. e. even if the pump is run with the gas ballast valve open.

2.5.1 Putting the Pump out of Operation

When putting the Chemvak out of operation, drain off the oil, flush out the pump with fresh oil and fill in the required amount of clean oil. Close the connection ports. Special preservation or slushing oils need not be used.

3. Maintenance

3.1 Maintenance Information/checking the oil level

Due to the design concept of the Chemvak pumps, maintenance is normally kept to a minimum. The work required is described in the sections below.

All work going beyond this level must be carried out by suitably trained personnel.

Maintenance work or repairs carried out incorrectly will affect the life and performance of the pump and may cause problems when filing warranty claims.

In this connection, your attention is drawn to Chemvak practical courses in which our experts provide instruction on the maintenance, repair and checking of Chemvak pumps. Further details are available on request.

If the Chemvak is used in ambient air containing many impurities, make sure that the air cooler

and the gas ballast device are not impaired.

Where the Chemvak is employed for corrosive media, we recommend that any maintenance work be carried out immediately so as to avoid corrosion during idle periods.

Disconnect the electrical connections for all disassembly work on the pump.

Make absolutely sure that the pump cannot be accidentally started.

3.1.1 Oil Level

During operation the oil level of the Chemvak must always be visible between the marks on oil viewing glass. The quantity of oil must be checked and topped up as required.

Recommendation: The oil level should always be visible in the middle of the oil viewing glass.

Caution: The pump must be switched off before topping up any oil.

3.1.2 Oil Condition

On our Chemvak pumps filled with N 62 oil, there are three ways of checking the condition of the oil.

a) Visual check

Normally the oil is clear and transparent. If the oil darkens, it should be changed.

b) Chemical check

The neutralization value is determined according to DIN51558. If it reaches 2, the oil should be changed.

c) Viscosity check

If the viscosity at 25 °C exceeds 0.3 Pa s, the oil should be changed.

If gases or liquids dissolved in the oil produce a deterioration of the ultimate pressure, the pump may be degassed by allowing it to run for approx. 30 min. with closed intake port and open gas ballast valve.

When an oil sample is needed so as to determine whether an oil change is required, it should be discharged via the oil-drain plug (4/6) into a beaker or similar receptacle with the pump switched off but still at operating temperature.



Warning

Dangerous substances may escape from the pump and oil. Appropriate precautions should be taken, e.g. use of gloves, safety mask or breathing mask.

Observe the safety rules

1. Valve cap
2. Reinforcement plate
3. Star washer
4. Valve
5. O-ring
6. Hex.head screw
7. 7Washer
8. Gas ballast valve housing
9. Spring
10. Gasket
11. Hond
12. Oil filter
13. O-ring
14. Circlip
15. Gasket

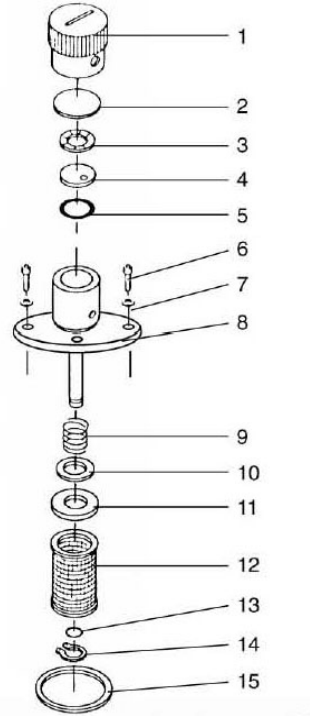

Fig.5 Dirt trap gas ballast valve disassembled

3.2 Oil Change

The oil should be changed after the first 100 operating hours and then at least every 2,000 to 3,000 operating hours or after one year. At high intake pressure and intake temperatures and/or when pumping contaminated gases, the oil will have to be changed more frequently.

Please arrange for the frequency of change oil as your different operate situation.

Further oil changes should be made before and after long-term storage of the pump.

If the oil becomes contaminated too quickly, Install a dust filter and/or oil filter.

(see section 1.3)

Contact us for more information in this matter.

Tool required: Allen key 8 mm

Always carry out the oil change when the pump is switched off but still warm.

Remove the oil-drain plug (4/6) and let the used oil drain into a suitable receptacle.

When the flow of oil slows down, screw the oil-drain plug back in, briefly switch on the pump (max. 10 s) and switch it off. Remove the oil-drain plug again and drain off the remaining oil.

Screw the oil-drain plug back in (check the washer and replace it if necessary).

Remove the oil-filling plug (4/1) and fill in fresh oil.

Then screw the oil-filling plug (4/1) back in.

Warning



If there is the danger that the operating agent may present a hazard in any way due to decomposition of the oil, or because of the media which have been pumped, you must determine the kind of hazard and ensure that all necessary safety precautions are taken.



Caution

We can only guarantee that the pump operates as specified by the technical data if the lubricants recommended by us are used.

3.2.1 Disposal of Used Pump Materials

The corresponding national environmental and safety regulations apply. This applies equally to used filters and filter elements (oil filter, exhaust filter and dust filter).

Warning



- In the case of hazardous substances determine the kind of hazard first and observe the applicable safety regulations. If the potential hazard still persists, the pump must be decontaminated before starting with any maintenance work.



- For professional decontamination we recommend our Chemvak service.
- Never exchange the oil or the filters while the pump is still hot. Let the pump cool

down to uncritical temperatures first. You must wear suitable protective clothing.

3.3 Cleaning the Dirt Trap

A wire-mesh filter is located in the intake port of the pump to act as a dirt trap for impurities. It should be kept clean in order to avoid reduction of the pumping speed.

For this purpose, remove the dirt trap from the intake port and rinse it in a suitable vessel using a solvent.

Then thoroughly dry it with compressed air. If the dirt trap is defective, replace it. The cleaning intervals depend on requirements. If large amounts of abrasive materials occur, a dust filter should be fitted into the intake line.

3.4 Maintaining the Oil Filter

Tools required: Allan key 5 mm

Unscrew the four hex head screws (5/14).

Take off the oil filter (5/12), gasket (5/10), spring (5/9) and O-ring (5/13).

Clean the parts and check that they are in perfect condition; if not, replace them (order no for replacement kit 310 01). Remount in the reverse order.

3.5 Maintaining the Gas Ballast Valve

Tools required: Allan key 5 mm Circlip pliers

Completely remove the valve cap (5/1)

Unscrew the four hex head screws (5/6) Remove the gas ballast valve housing (5/8)

Remove the circlip (5/14)

Take off the oil filter (5/12), gasket (5/10), spring (5/9) and O-ring (5/13).

Remove the gasket (5/15)

Clean the parts and check that they are In perfect condition; If not, replace them.

Remount In the reverse order.

3.6 Maintenance Plan (Recommendation)

No.	Chemvak WH-8D	Measurement / test quantity	Interval						Remarks
		WH-17D	Operating /auxiliary materials	VE	VP	t	6m	a	n-a

1	Operate the pump for at least 0.5 hours with gas ballast.				x				Condensed water is thus removed from the oil.
2	Check the oil level, change the oil if required.	Oil: N 62 or special and alternative oils, see Section 1.3	x		x				Refill: only after the pump has been switched off.
3	Check the quality of the oil, change the oil if required.	Visually Chemically mechanically	x		x		x	x	Visually: normally light and transparent, oil change is required when discolorations increase. Chemically: to DIN 51558 when the neutralization number exceeds 2; then an oil change will be required. Mechanically: when dynamic viscosity at 25 °C exceeds 300 mpas; then an oil change will be required. Disposal of waste oil: see section 3.2.1
4	Clean the dirt trap in the intake port, change it as required.	Suitable cleaning agent and compressed air					x		Clean dirt trap with a cleaning agent and blow it out Replace the defective dirt trap. Use a cleaning agent which complies with the national / international specifications. Observe the safety regulations when using cleaning agents
5	Clean the internal demister, change it as required	Suitable cleaning agent						x	Already clean before the maintenance interval has elapsed when the noise level increases. Clean the internal demister using a cleaning agent. Replace the defective internal demister. Dispose of the defective internal

									demister as special waste. Cleaning agent according to national/international specifications. Observe the safety regulations when using cleaning agents.
6	Check the edges of the teeth on the coupling element for any damages, change the coupling element as required							x	
7	Change the oil – and clean the oil level glass.	Oil: N 62 or special and alternative oils. Suitable cleaning agent and compressed air.						x	Oil change: First oil change after 100 operating hours Pump switched off and cold. Change the oil when the pump is cold in order to avoid releasing absorbed gases. Clean the oil level glass with a cleaning agent and blow it out with compressed air under a suction hood. Cleaning agent according to national / international specifications.
8	and the motor as well as the cooling fins on the motor for deposits and clean as required.	Brush and industrial vacuum cleaner.						x	Already clean before the maintenance interval has elapsed when the pump or the motor gets to warm. Caution: switch off the pump and ensure that it can not run up inadvertently (disconnect from the mains).

Key to the maintenance plan

VE=Maintenance before switching on the system

VP=Maintenance before starting production

t=Daily maintenance

w=Weekly maintenance a=Annual maintenance

n-a=Maintenance every n years

m=Monthly maintenance

3m=Three monthly maintenance

6m=Six monthly maintenance

2w=Twice weekly maintenance

We recommend that you service the pump every two years concerning the following:

- Cleaning
- Checking of the individual components
- Exchange of all seals
- Function check

This check should be run by the Chemvak service.

4. Trouble shooting

Fault	Possible reason	Remedy
Pump does not start.	Wiring is malfunctioning. Operating voltage does not match motor. Motor is malfunctioning. Oil temperature is below 10 °C. Oil is too vis	Check and repair wiring. Replace the motor. Replace the motor.
	Exhaust filter or exhaust line is clogged. Pump is seized up (sign: pump is jammed).	Heat the pump and pump oil or use different oil. Change the oil. Replace the filter or clean the exhaust line. Repair the pump.
Pump does not reach ultimate pressure.	Measuring technique or gauge is unsuitable. External leak1). Anti-suck back valve is malfunctioning. Exhaust valve is malfunctioning. Oil is unsuitable. Intake line is dirty. Pump is too small.	Use correct measuring technique and gauge. Measure the pressure directly at pump's intake port. Repair the pump. Repair the valve. Repair the valve. Change the oil (degas it, if necessary). Clean vacuum lines. Check the process data; replace the pump, if necessary.

Pumping speed is too low.	Dirt trap in the intake port is clogged. Exhaust filter is clogged. Connecting lines are too narrow or too long.	Clean the dirt trap; Precaution: install a dust filter in intake line. Exchange the filter element. Use adequately wide and short connecting lines.
After switching off pump under vacuum, pressure in system rises too fast.	System has a leak. Anti-suck back valve is malfunctioning.	Check the system. Repair the valve.
Pump gets hotter than usually observed.	Cooling air supply is obstructed. Ambient temperature is too high. Process gas is too hot. Oil level is too low. Oil is unsuitable. Oil cycle is obstructed. Exhaust filter or exhaust line is obstructed. Exhaust valve is malfunctioning. Pump module is worn out.	Set pump up correctly. Set pump up correctly. Change the process. Add oil. Change the oil. Clean or repair the oil lines and channels. Replace the exhaust filter, clean the exhaust line. Repair the valve. Replace the pump module.
Oil in the intake line or in vacuum vessel.	Oil comes from the vacuum system. Anti-suck back valve is obstructed. Sealing surfaces of anti-suck back valve are damaged or dirty. Oil level is too high.	Check the vacuum system. Clean or repair the valve. Clean or repair the intake port and the anti-suck back valve. Drain the excess oil.
Oil is turbid.	Condensation.	Degas the oil or change the oil and clean the pump. Precaution :open the gas ballast valve or insert a condensate trap.
Pump is excessively noisy.	Oil level is much too low (oil is no longer visible). Silencing nozzle is clogged. Intake pressure is too high. Internal demister is clogged. Coupling element is worn. Vaness or bearings are damaged.	Add oil. Clean or replace the silencing nozzle. Lower the intake pressure. Clean or replace demister. Install new coupling element. Repair pump.

* Repair information :refer to the Section in the Operation Instruction stated here.

- 1) Bubble test: the warm pump with degassed oil is running without gas ballast and the intake blanked off. The exhaust line is led in to a vessel with water. If an evenly spaced line of bubbles appears, then the pump has an external leak

5. Warranty

We guarantee the perfect functioning of this instrument against defects in material, design, and workmanship, when use under appropriate conditions and in accordance with the instruction manual for a period of **TWO YEARS** from the date of initial shipment.

This warranty covers all parts and components of the instrument except those normally requiring frequent replacement, such as tubing, gasket, O-rings, etc. We will not be liable for any personal injury, improper maintenance, or negligence of accident.

6. Product Liability

Under no circumstances shall Chemvak be liable for indirect, consequential or otherwise special or unrelated damages of any kind.

Chemvak reserves the right to make technical changes without prior notice.

Email: info@chemvak.com

Web Site: www.chemvak.com