



MMM Group

Instructions for use

Laboratory drying ovens and incubators
line Standard

ECOCELL 22, 55, 111, 222, 404, 707

DUROCELL 22, 55, 111, 222

VENTICELL 22, 55, 111, 222, 222/2, 404,
404/2, 707, 707/2

INCUCELL 22, 55, 111, 222, 404, 707

INCUCELL V 22, 55, 111, 222, 404, 707

CE



Congratulations on obtaining a new temperature cabinet, designed for uniform tempering of various materials by hot air at a selectable temperature and a selectable time mode in laboratories. There is an air flap installed that enables wet material drying. The temperature course is controlled by an advanced microprocessor (Fuzzy logic) with a digital display and a temperature sensor PT 100. This system ensures high accuracy of temperature regulation and tempering process reliability.

The units meet technical and legislative requirements and they are designed according to respective EN standards. The units are made of high quality materials by using the latest technology. Each piece undergoes a careful output control.

Provided you will follow the instructions mentioned here the unit becomes your reliable and powerful partner.

Now these advantages will be available just for you. This unit will help to solve your everyday problems and it will become powerful assistant for you. This unit is very easy to use, nevertheless, we recommend you to read the Operating instructions carefully so that you could use all advantages of this unit and obtain complete knowledge for its optimal use.

CONTENTS:

6. 9. 2013

1	GENERAL.....	3
1.1	PURPOSE AND USE.....	3
2	IMPORTANT INSTRUCTIONS.....	3
2.1	UNPACKING, CHECKING AND TRANSPORT.....	3
2.2	BEFORE INSTALLATION.....	3
2.3	USEFUL SPACE.....	5
3	DESCRIPTION OF THE UNIT.....	5
3.1	GENERAL VIEW.....	5
3.2	POWER CONNECTION AND CONNECTORS.....	6
3.3	CONTROL PANEL.....	7
4	FUNCTION AND OPERATING.....	7
4.1	STARTING AND SWITCHING-OFF.....	7
4.2	SETTING-UP THE REQUIRED VALUES OF TEMPERATURE, TIME-DELAYED SWITCHING-OFF, NUMBER OF CYCLES, TIME-DELAYED PROGRAM START	8
4.3	USER MENU.....	9
4.4	ALARM FUNCTION.....	9
4.5	PROTOCOL PRINTING.....	9
4.5.1	INSTALLATION AND SETTING OF THE PRINTER.....	10
4.5.2	PRINTING.....	10
4.6	SAFETY SYSTEM FUNCTION AND SETTING.....	10
4.6.1	CHANGE OF MAXIMUM AND MINIMUM VALUES.....	11
4.6.2	SUPERVISORY CIRCUIT DIAGRAM FUNCTION.....	11
4.6.3	TEMPERATURE LIMITS OF THE UNITS.....	11
4.6.4	CHECKING THE SAFETY RELAY FUNCTION.....	11
4.6.5	CHECKING THE CORRECT ACTIVITY OF THE SAFETY SYSTEM.....	11
4.7	LIST OF ERROR MESSAGES.....	12
4.7.1	NOT DISPLAYED ERRORS.....	13
4.8	ADJUSTING AND FUNCTION OF THE AIR FLAP.....	13
4.9	EXCHANGING THE DOOR SEALING AND ADJUSTING THE DOOR.....	14
5	PARAMETERS OF THE UNIT.....	16
5.1	ELECTRIC CONNECTIONS.....	17
6	CLEANING AND DECONTAMINATION OF THE UNIT.....	17
7	MAINTENANCE.....	18
8	WARRANTY AND SERVICE.....	18
9	TRANSPORT AND STORAGE.....	18
10	THE WAY OF LIQUIDATION OF PACKAGE AND DISCARDED UNIT.....	19
11	OPTIONAL EQUIPMENT.....	19
11.1	DOOR WITH WINDOW AND INNER LIGHTING (EXCEPT IC, ICV EXCEPT IC, ICV FOR ALL THE TYPES OF THE VOLUME OF 22).....	19
11.2	ACCESS PORTS OF DIAMETER 25, 50, 100 MM.....	20
11.3	LOCKABLE DOOR.....	20
11.4	LEFT DOOR VERSION.....	20
11.5	FLEXIBLE PT100 SENSOR.....	20
11.6	SUPPORTIVE SW FOR PC.....	20

11.6.1	RECORDING SW - WARMCOMM - FOR PC UNDER WINDOWS.....	20
11.6.2	RECORDING PRINTING SW - PRINTER ARCHIV - FOR PC UNDER WINDOWS.....	20
11.7	HEPA FILTER.....	20
11.7.1	INSTALATION OF HEPA FILTER, FILTER DIMENSIONS, FUNCTION AND FILTRATION CHARACTERISTIC OF THE AIR FILTER.....	21
11.8	TWO-DOOR PASSING - THROUGH VERSION.....	21
11.8.1	VENTICELL 222/2 - INSTALLATION DATA.....	22
11.8.2	VENTICELL 404/2 - INSTALLATION DATA.....	22
11.8.3	VENTICELL 707/2 - INSTALLATION DATA.....	23
11.8.4	DOUBLE-DOOR THROUGH VERSION WITH AUTOMATIC DOOR BLOCKING.....	24
11.8.5	DOOR BLOCKING ERRORS.....	24
11.9	ANTI-DRY MODIFICATION FOR CULTIVATING MEDIUMS AND TISSUE CULTURES.....	25
11.10	NO-POTENTIAL CONTACT - ALARM.....	25
12	EMERGENCY DOOR OPENING.....	25

APPENDICES:

EC - DECLARATION OF CONFORMITY

1 GENERAL

The electrically heated ovens/incubators are designed for laboratories, especially for tempering of various materials by hot air at adjustable temperature and optional time mode. An air flap enables to dry wet materials.

An advanced modern microprocessor (Fuzzy - logic) with a digital display and a PT 100 controls the temperature course. This system provides high accuracy of temperature control and reliability of the tempering process. The second independent digital safety system ensures, together with the second independent temperature sensor, the control and safety of the tempering process for the whole device life.

These devices meet all legislative requirements and are designed according to respective EN standards – see Conformity Declaration. They are made of high-grade materials by using the latest technology.

Each unit undergoes a careful output control.

1.1 PURPOSE AND USE

ECOCELL (EC) is intended for tempering of materials by hot air with natural circulation. The units are designed for temperatures up to 250 °C, optionally up to 300 °C. Compared with **VC** units they are characterized by quiet operation and lower consumption of electrical energy.

DUROCELL (DC) serves for hot-air tempering with natural circulation (use for the following procedures: Acid hydrolysis, extraction of non-flammable substances, thermal decomposition in closed vessels). The devices are intended for temperatures up to 125 °C. The inner surfaces of the chamber are covered with an EPOLON layer which protects the chamber against corrosive action of acids in form of liquids or vapours in case of their accidental leakage from closed vessels. For other important information see the chapter Before Putting into Operation.

VENTICELL (VC) is intended for tempering of materials by hot air with forced air circulation by means of a fan. The ovens are designed for temperatures up to 250 °C, optionally up to 300 °C.

INCUCELL (IC, ICV) serves as an incubator or for cell cultivation in microbiological laboratories (see chapter Optional equipment; Anti-dry modification of cultivating mediums and tissue

cultures). The units are designed for temperatures up to 70 °C optionally up to 100 °C. A quiet operation is characteristic for the version **IC** (without a fan), more accurate temperature regulation with small deviations is characteristic for the version **ICV** (with ventilator).

2 IMPORTANT INSTRUCTIONS

2.1 UNPACKING, CHECKING AND TRANSPORT

Please check after unpacking whether the unit and its accessories are complete and not damaged. An eventual damage has to be reported to the transporting company immediately. During the manipulation – in case of lifting the cabinet etc. – the unit must not be held by the rail or door. The units of volumes 404 and 707 shall be lifted by means of supplied hooks; the casters are designed for local moving only, not for longer transport. A standard delivery consists of a temperature cabinet and two sieves, three chip cards formatted for program download (marked Programs – empty) and one special operations card (SO).

Attention: If an SO card is used for a program download, its original function will be cancelled.

2.2 BEFORE INSTALLATION

- **Please read carefully the Operating Instructions before starting the work with the unit!**
- Install the instrument by plugging the power cord to a line voltage socket. The specified parameters of the connection are described in chapter 5.1 - Electrical Connection.
- At temperatures of above 100 °C the inner chamber surface becomes yellowish. This coloration is neither the material nor the device defect.





After the first starting of the unit the heating elements and insulation start to be baked with a typical smell; after a few operation cycles this smell disappears, nevertheless, it is suitable, during the insulation baking at a temperature above 100 °C, to provide a sufficient air exchange (e.g. by ventilation or exhaustion).

 With **VC** and **EC** types the air exhaust is protected by a cover at the rear wall of the unit. This cover is placed inside the unit while shipping. When installing the unit, insert the cover into the horizontal openings below and above the exhaust to attach it behind the exhaust.

 **DC-type** – regarding the fact that it is the inner chamber only which is resistant to corrosive effects, the following must be ensured during the application:

- a) Processes specified in the previous chapter must be performed in the chamber in closed vessels (corrosive substances release into the chamber must be prevented);
- b) Exhalations from the exhaust outlet must be exhausted actively to prevent vapour condensation on the outlet and its dripping down to the electric part of the device;
- c) The whole device must be placed in a no-corrosive atmosphere (damage of the source and regulation electronics must be prevented).

 The units are designed for indoor operation within the ambient temperatures ranges from 5 °C to 40 °C and at maximum relative humidity 80 %.

 The oven shall be installed in a distance of min. 100 mm from the rear and sidewalls. The temperature of the outlet air on the exhaust may be up to 250 °C (or 300 °C);

this area is labeled by . The walls near the oven shall be incombustible.

 The load-bearing capacity of the floor during installation of the device shall correspond to the weight of the unit itself taking the weight of the maximum charge into consideration (see **chapter 5 - Parameters of the Unit**).

 The unit must not be placed on a support that could cause a danger of fire or smothering in case of falling some hot object out of the unit.

 **No inflammable, explosive or toxic materials may be put into oven! The same applies to materials that could release such substances.**

 Material is only to be put on trays, never directly on the bottom of the unit!

 No articles may be put on the external surface of the unit.

 The unit is not intended for warming up the liquids.

 The units are not intended for use in the atmosphere with a possible danger of flammable or explosive anesthetics.

 **Any assembly or disassembly may be done only when disconnected from the mains! After switching the unit off with the key (key 11, fig. 4) the unit comes only to a stand-by mode, however, it is not disconnected from the mains!**

- If the unit is not used for a longer time, disconnect it from mains by pulling the power cord out of the socket.



 The units are supplied with the maximum permitted temperature set to the maximum.

 The power cord must not come in contact with hot parts of the units – with the exhaust hole cover.

- Protection of the temperature box, its surroundings and processed material against inadmissible temperature excess is secured by a safety system.

 Pull out and subsequently push in the upper metal plate piece of internal chamber carefully, there is a danger of cutting through the rubber gasket of the chamber through careless manipulation.

 The maximum permitted loads: see chapter **5 - Parameters of the Unit**.

  When operating the cabinets at high chamber temperatures there can be the maximum allowed temperature of 70 °C at their external surface (exhaust ports and their surroundings and the surroundings of the chamber sealing, window and door surface in case of the optional type with window in door) surpassed and there is a danger of burns. Please be very careful.

- During the operation of the devices of 404 and 707 at high temperatures a deformation of the inner door surface occurs as a consequence of thermal tension, which makes their closing more

difficult. If you open the door in this state, do not close them until the chamber is cooled down. Otherwise the door mechanism could be damaged.



Regularly – in daily intervals – check by listening if after the start the fan of the case is running.

2.3 USEFUL SPACE

The useful space is illustrated on Fig. No.1, where $X(D) = 10\%$ of the inner chamber depth, $X(W) = 10\%$ of the inner chamber width, $X(H)_1$ is the distance from the lowest tray to the bottom of the inner chamber, $X(H)_2$ is the distance from the upper most tray to the ceiling of the inner chamber. The required temperature accuracy - see chapter 5 - **Parameters of the Unit** - is achieved only within the space defined above (in connection with DIN 12 880 - marked with thick lines, thinner lines mark the inner chamber walls). (It means, that over the last upper tray the limits from chapter 5 - **Parameters of the unit** - are not obligatory).

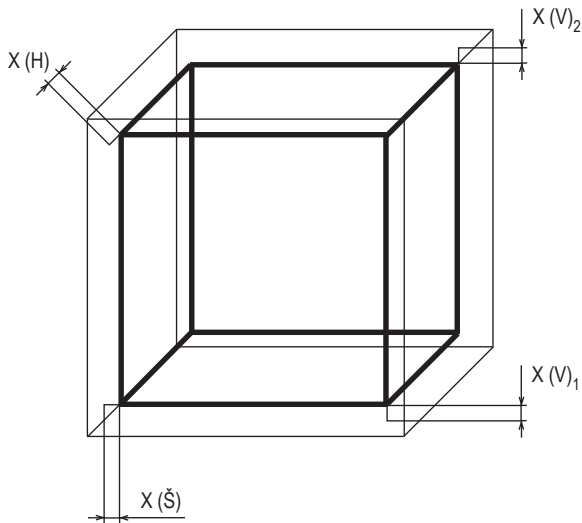

Fig. 1

3 DESCRIPTION OF THE UNIT

3.1 GENERAL VIEW

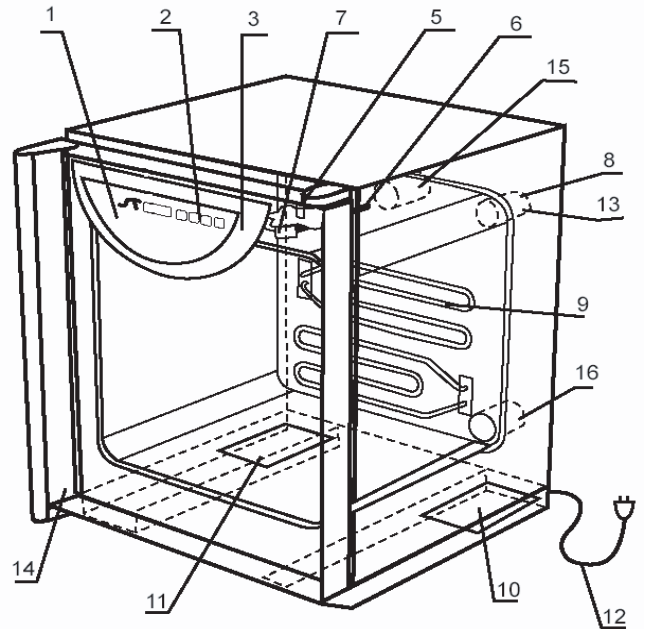
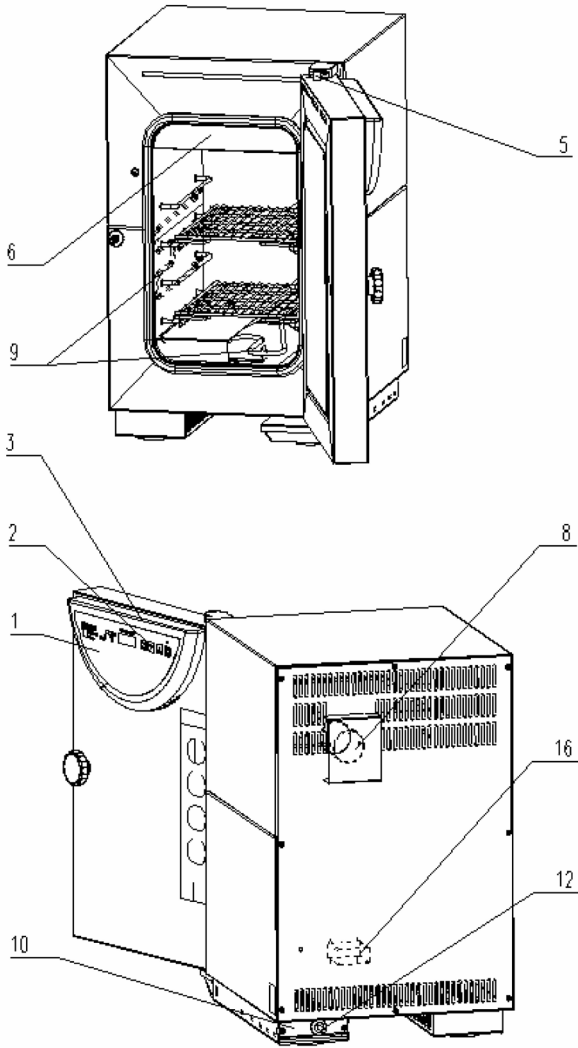

Fig. 2

- 1 - controller panel
- 2 - control keys
- 3 - plastic cover of the controller panel
- 5 - lever for air flap positioning
- 6 - case of PT 100 sensor
- 7 - fan (only for VC, ICV)
- 8 - exhaust with air flap (with all types)
- 9 - heating elements
- 10 - power board I
- 11 - power board II (only three-phase type)
- 12 - mains cord
- 14 - door sensor
- 15 - suction hole (only for VC, ICV, with air flap)
- 16 - suction hole (with types EC, DC, IC)

ECOCELL 22



VENTICELL 22

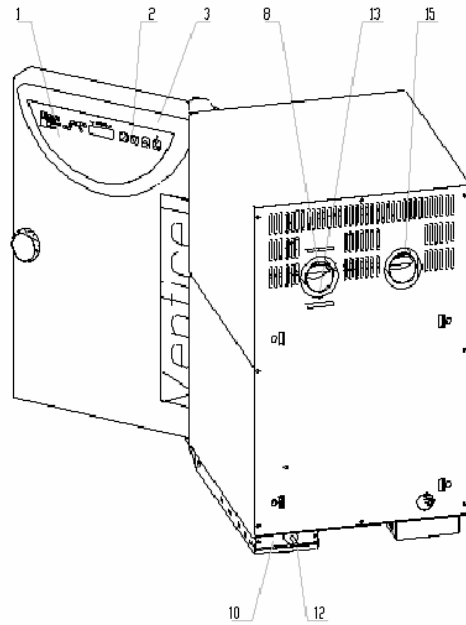

3.2 POWER CONNECTION AND CONNECTORS

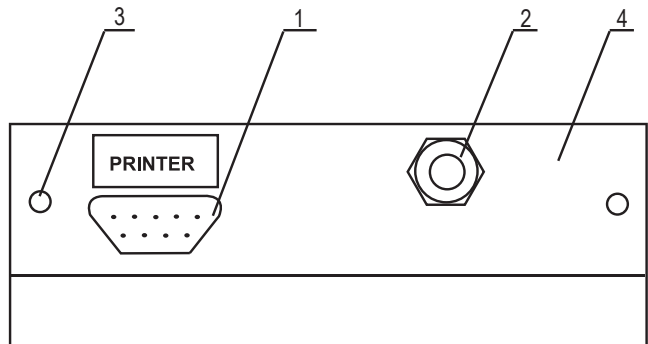
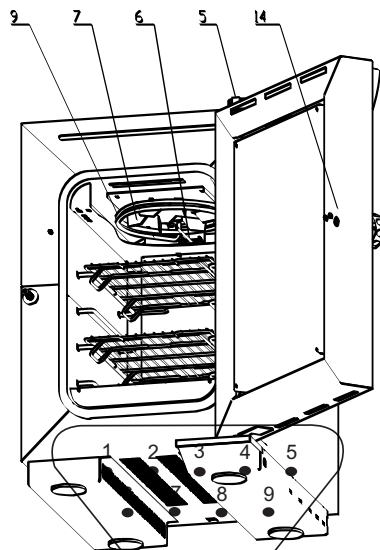

Fig. 5: Foot of the unit with mains cord - rear view (with the power board I)

- 1 - Interface for printer
- 2 - Mains supply
- 3 - Screws attaching the power board
- 4 - Power board panel (located in the foot)

VENTICELL 22



9 Canon connector on the case

Pin	Signal
2	RX
3	TX
5	GND
6	DSR

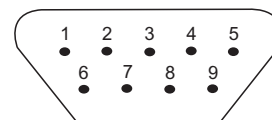

Fig. 6: 9 Canon - Interface for protocol printer

25 Canon connector in the printer

Pin	Signal
2	TXD
3	RXD
7	GND
20	DTR

The appliances, which are connected with the connector RS-232C, must comply with valid regulations in terms of electric safety and electromagnetic compatibility.

Interface parameters: Baud 9600
 Stopbit: 1
 Parity: none
 Databit: 8

3.3 CONTROL PANEL

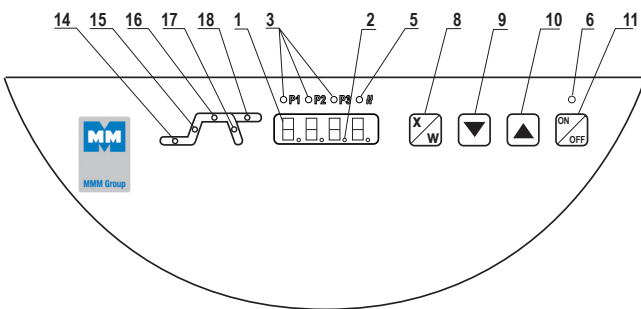

Fig. 4

- 1 - display
- 2 - decimal point - burns (the unit is connected to the mains - stand-by mode)
- 3 - the indicators of pre-selected programs:
 - burn: program is active
 - blink: program will be active in 5 sec.
- 5 - heating indicator light - burns: condition of temperature regulator - heating active
- 6 - power indicator light - burns after switching the unit on by ON/OFF switch
- 7 - Safety system indicator is flashing: The temperature exceeded the chosen limit set by the protective thermostat – the heating is switched off (see more in Chapter 4.6 Safety System Functions and Setting)
- 8 - setting mode activation key
- 9 - setting the value downwards
- 10 - setting the value upwards
- 11 - switch (ON - switched on, OFF - stand by mode)
- 14 - Indicator light: blinks - set-up mode, burns - the active part of the program is time-delayed switching-on

- 15 - indicator light: blinks - set-up mode, burns - the active part of the program is heating-up to present temperature
- 16 - indicator light: blinks - set-up mode, burns - the active part of the program is time-delayed switching-off
- 17 - Indicator light: blinks - set-up mode, burns - decrease of temperature after switching-off
- 18 - Indicator light: blinks - set-up mode, burns - the active part of the program is infinite stay on the present temperature.

Indicator lights 14-18 blink - number of cycles setting mode.

4 FUNCTION AND OPERATING

The unit can be set to various modes according to the required function, i.e. the unit's cycle can be modified, as described below. In the figure a complete course of one cycle with its stages is shown.

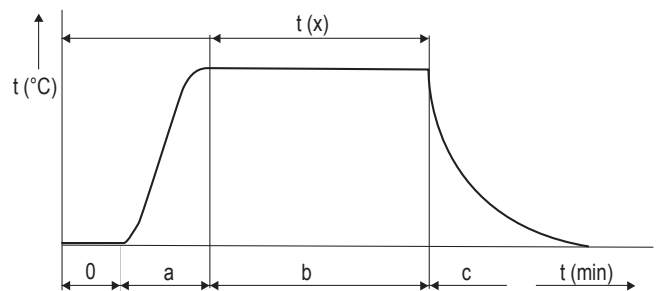

Segment	Function
0	time-delayed switching-on,
a	rise to the temperature,
b	time-delayed switching-off
c	temperature drop after switching off

The functions of the respective indicator lights are described in chapter 3 - **Description of the Unit**, and 3.3 - **Control Panel**.

4.1 STARTING AND SWITCHING-OFF

- 1. In case, that the unit was in the stand-by mode before switching-off, a green dot in the right lower part of the display will lit up, otherwise the program, interrupted by switching off, will continue.

2. Press the key **ON/OFF**. The indicator light above the key, the indicator light of the pre-selected program and the indicator light of the initial active program stage will lit up. If the temperature in the chamber will be lower than the preset value, the heating indicator light will burn as well - either permanently or blinking (depending on heating controller status - on or off).
3. Press the key **ON/OFF**. The display turns off, only the green indicator light in the lower right part is on (stand by). The total disconnection from mains (in case of a long-term putting out of operation or a maintenance) is achieved by pulling the mains cord from a socket – see also chapter **Before installation**.

4.2 SETTING-UP THE REQUIRED VALUES OF TEMPERATURE, TIME-DELAYED SWITCHING-OFF, NUMBER OF CYCLES, TIME-DELAYED PROGRAM START

1. Set the pre-selection of the program 1 or 2 or 3 by pressing the key ▼ or ▲, after pressing the key ▼ or ▲ the indicator light of the next program will start to blink. This program will be activated in ca. 5 sec, if no other key is pressed during this time. Setting by means off ▼ or ▲, will cause the stop of the actually running cycle and starting a new cycle with the pre-selected parameters. The setting-up cycle begins with setting the required temperature.
 2. Press the key **X/W**, indicator lights 15, 16 (Fig.4) start to blink, by pressing the keys ▼▲ set the required temperature in °C on the display. The lowest temperature interval, which can be set and displayed with EC, DC, VC is 1 °C; with IC, ICV it is 0,1 °C. The indicator lights of the segments blink permanently.
 3. By pressing the key **X/W** change over to the setting of time-delayed switching-off, by pressing the keys ▼▲ set the required value in hours and minutes from 0 to 99 hrs and 59 min on the display, thereby the indicator lights 16, 17 (Fig.4) blink. The symbol --- corresponds to the timely unlimited exposure.
 4. By pressing the key **X/W** change over to the setting of number of cycles and by pressing the keys ▼▲ set the number of cycles from 1 up to 255 (more information on the cycles see 4.3) - all indicator lights blink during the setting up. This function can be used only with the time-delayed switching-off ≠ 0.
- Select the option of cycles setting by using the user menu.
5. By pressing the key **X/W** change over to the stage of setting the time-delayed starting and by pressing the keys ▼▲ set the required value in minutes from 0 up to 99 hrs 59 min, the indicator light 14 (Fig.4) blinks.
 6. Start the program by double pressing the key **ON/OFF** (the program start is announced by an acoustic signal). Actual temperature with time countdown will blink on the display during the time-delayed program starting. The heating is switched on after reaching the time of zero and the display shows the actual temperature in the chamber. After reaching the required temperature:
 - a) in case of setting the time-delayed shut down, the chamber temperature with the preset time countdown starts to change on the display or
 - b) in case of time unlimited switching-off, the chamber temperature with the count up time starts to change on the display. After 99 hours:59 min pass, time is displayed in hours up to 999 hours. It is then displayed by ∞ symbol (infinity). When printing the record on the printer, time is shown up to 999:59; the text "infini" is then printed.
 Continuously lighting indicators inform about the actual active phase of the programme. The permanently lighting indicator lights provide information on the actually active program stage.
 7. Individual values can be checked during the program run - by pressing the key **X/W** the required value is shown on the display, the indicator lights blink, by the next pressing of the key **X/W** within 5 seconds you will change over to the next stage, in this way all settings can be checked step by step. The original program will continue, if no control element within 5 seconds will be used.
 8. In the similar way, you can change the already set values during the programme operation, if
 - a) you will wait ca 5 second after setting of new values, the programme continues with changed values from the break point.
 - b) after setting the value you can start the program by double pressing the key **ON/OFF**, the program will start with new values from the beginning.
- Fan run and program end:
With all types containing fan the fan runs for 5 minutes after the program end and then it is switched off.

4.3 USER MENU

Enter the functions by pressing **X/W** + ▼ concurrently.

After you enter the functions, LEDs of all three programmes switch on. Select the required function U1, U2, ... by means of the button ▼▲ and enter the function by **X/W**. After you enter:

- a) U1 – printer's printing period setting (Per.P) from 1 to 255 min, or the print period switch-off ("OFF") by means of buttons ▼▲.
- b) U2 – (CYcl) On or OFF – cycles permit or prohibition are set by means of ▼▲ (for all pre-sets at once); a cycle means a multiple programme repetition with a pre-set delayed switching off and on.
- c) U3 - Prn or PC – data transfer via interface RS 232 either onto the printer (Prn) or, in case of using the program WarmComm, onto the computer (PC); set the sign Prn or PC by means of ▼▲.
- d) U4 – setting of the fan speed (VEnt). The speed could be changed in steps: 50, 60, 70, 80, 90 and 100 %. The initial setting is 100 %. The speed is regulated with the accuracy of ± 5 %.
- e) U5 - enabling (ON) or disabling (OFF) of the acoustic signaling at the exposure end (after the end of the last cycle in case of cycling). Within the original adjustment the acoustic signalling is permitted.
- f) U6 - Safety system functioning as a protective thermostat
User safety upper temperature limit – setting of the maximum user-permitted exposure temperature (SFt.H). Change this value by means of ▼▲ and confirm by ON/OFF pressing. When setting this maximum value, the real temperature course, namely its potential overshoot during temperature rising, must be taken into account. If the pre-set maximum permitted temperature is lower than the required exposure temperature, the display shows the warning "SEt tEMP CroSSEd SAFEtY USEr LiMit", because the safety system would otherwise be activated during the cycle. The resolution and range of the setting correspond to the resolution and range of the required temperature. The highest temperature has been pre-set as default.
- g) U8 – Safety system – setting of the maximum onset phase duration (SPt.f). After ▼▲ pressing, the actual maximum onset phase duration is displayed. It can then be changed by 1-hour steps within the range from 1 to 24 hours, or the time watching can be switched off, which is then displayed in form of "OFF".

Confirm by **ON/OFF** pressing. Default setting: Time watching is switched off.

- h) U9 – Selection of flexible sensor displaying. (Yes/No).
- i) U14 – Alarm – setting of the permitted lower deviation from the required exposure temperature (dlt.L). Set the deviation by means of in the range from -0.1 to -99.9 °C, or the function can be switched off, which is displayed as "OFF". The alarm function has been switched off as a default.
- j) U15 – Alarm – setting of the permitted upper deviation from the required exposure temperature (dlt.H). Set the deviation by means of in the range from +0.1 to 99.9 °C, or the function can be switched off, which is displayed as "OFF". The alarm function has been switched off as a default.

Exit any user function setting by **X/W** pressing.
Exit any user function selection by **ON/OFF** pressing.

4.4 ALARM FUNCTION

The alarm function can be used for the real chamber temperature watching. Set the maximum (upper) and minimum (lower) permitted deviations in user settings U14 and U15. The said values are then watched by the control unit. If the actual temperature drops below the lower value during the exposure phase, the appropriate message "Lo ALArm" is displayed till its cancellation by **X/W** button. If the actual temperature exceeds the upper limit during the temperature rise, exposure and cooling, the appropriate message "Hi ALArm" is displayed till its cancellation by **X/W** button. The alarm switch-on or cancellation is recorded to the printer or the PC programme. The alarm performs no other than informing activity.

ATTENTION! The alarm has an information function only. It will neither remove nor restrict the cause of the alarm. To restrict the heating in case of a defect, use the safety system and its setting in U6.

4.5 PROTOCOL PRINTING

DPT 6333 printer is recommended for the record printing on the printer. Other printers may also be used, e.g. CITIZEN, model iDP 3110-24 RF-A. Printing to a PC application (Printer Archiv) is allowed as well.Archiv.

4.5.1 INSTALLATION AND SETTING OF THE PRINTER

DPT-6333-V24 does not require any microswitch setting by the user.

Setting the DIP microswitches of the printer
CITIZEN iDP 3110:
all four pins are in the lower position OFF.

Setting the DIP microswitches of the printer
CITIZEN CBM 910:
OFF / ON / OFF / ON / OFF / ON / ON / OFF
(from the left to the right).

CBM 910II: OFF / ON / OFF / OFF / OFF / OFF
/ ON / OFF.

After the setting is changed, the printer must be switched off and on either by the switch or by disconnection from the power supply.
(A different type of the printer must be adjusted with the help of the printer's manual and the data on the interface RS232 shown on the case.)

Connect the printer to the device by means of a cable with serial connector (RS-232C). Connect one end of the cable to the printer socket (see Fig. 4) and the other one to the connector in the rear part of the printer. Connect the printer to the electric power mains by means of an adapter. Some types require the switch on the right side of the printer to be switched on. The indicators POWER and SEL light up. The printer is in the on-line mode. Paper is fed by pressing the LF button (in the on-line mode only, i.e. after the SEL button pressing – the SEL indicator turns off. To renew the on-line mode, the SEL button must be pressed – the SEL indicator lights up). The printer can print in the on-line mode only!

Follow the chapter User Support Functions to set the type of data from the COM output connector (user mode U3) and the required print interval (user mode U1).

By the printer interval setting you can determine the time intervals of actual chamber temperature printing. The interval is shown in the record heading.

The printer interval can be set on the display in the range from $t_{min} = 1 \text{ min}$ to $t_{max} = 255 \text{ min}$ (i.e. 4 hours 15 min) in 1-minute increments.

4.5.2 PRINTING

1. The printer prints out the heading showing the device type, programme number, number of cycles, pre-set temperature, time of the start delay, and the required time interval.
2. Then the printer prints out the procedural data and titles of the procedural data columns (physical unit inclusive).
3. Below that, the values of the following procedural data are printed out:
 - Actual temperature in the chamber;
 - Time from the programme start.
4. Other printed data:
 - Start of individual phases;
 - Change of any required value;
 - Change of a user function influencing the cycle procedure (U1, U3, U4, U6, U8) m, including the new value printing;
 - Alarms activation/deactivation, including the description;
 - For IC,ICV: Activation or deactivation of the safety system warning, including the description;
 - Error state activation, including the description.
5. In case of power failure and subsequent power recovery, the printer prints out "--> Power recovery!" Counting of the printing time intervals starts from the moment of power recovery. A new heading is printed out after switching the device off and on by means of **ON/OFF**.
If there is a power failure of the printer only, or if the printer is switched off, the printer shows no message after the power recovery or the printer switch-on.

4.6 SAFETY SYSTEM FUNCTION AND SETTING

The safety system watches the exposure process controlled by the control circuit. It also performs the function of a safety thermostat and serves to protect the temperature box, its surroundings and the processed material against an inadmissible excess of the set temperature (it will e.g. prevent the damaging or destruction of material samples in case of the temperature regulator damage, or unintended setting of a higher temperature than that tolerated by the sample in the unit chamber). Supervision is performed both under the normal operation and in a Stand By.
The safety system measures the temperature independently at the same place like the regulatory sensor and counts the time

independently. If the set maximum temperature and period of time are exceeded, the safety relay switches off the heating, indicates the error state by its indicator flashing (red) and passes the information about the error to the controlling unit which then passes to the error regimen and indicates the error.

To cancel the error by the user, hold **X/W**. The controlling unit cancels the error state in the safety system circuit. The device passes to a break state in which parameters can be reset, or you can let the chamber cool. The device is put into operation by pressing **ON/OFF**.

4.6.1 CHANGE OF MAXIMUM AND MINIMUM VALUES

It is performed in the user settings U6, U8 – see the safety system function diagram and description of the user settings. Minimum difference from the set regulated temperature should be $\pm 5\text{ }^{\circ}\text{C}$.

4.6.2 SUPERVISORY CIRCUIT DIAGRAM FUNCTION

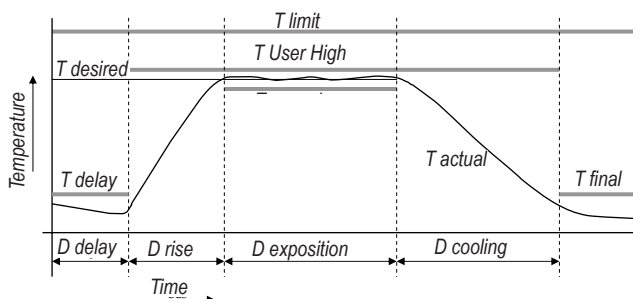

T limiting – threshold temperature is the maximum operation temperature permitted by the manufacturer in all phases and watched by the safety system. Its value depends on the device type and cannot be changed.

T User High – safety user upper temperature limit is the maximum temperature permitted by the manufacturer for the phase of temperature rise, exposure and cooling, pre-set in U6 and watched by the safety system.

T delay – maximum allowable temperature of the delayed switching phase. It is set itself at the cycle beginning to the sum of the actual temperature plus $30\text{ }^{\circ}\text{C}$.

T final - maximum permitted temperature after termination of cooling. It reaches the T exp max temperature or $55\text{ }^{\circ}\text{C}$, whichever is lower.

D delay - time of the delayed switching may vary from the set time for $\pm 2\text{ min}$.

D rise - max. rise time according (Safety Time) to the setting in the user mode U8.

D exposition - exposition time may vary from the set time for $+3\text{ min} / - 0\text{ min}$.

D cooling - max. cooling time is set to 24 hours.

4.6.3 TEMPERATURE LIMITS OF THE UNITS

ECOCELL	280 °C
DUROCELL	150 °C
VENTICELL	280 °C
VENTICELL	300 °C 330 °C
INCUCCELL	100 °C
INCUCCELL	100 °C 130 °C

4.6.4 CHECKING THE SAFETY RELAY FUNCTION

The test is performed automatically in the phase of the temperature rise, without the cycle influencing, and after the period between tests elapsing (3,000 hours). The said time is counted in the exposure phase. After the device is connected to the power mains, the safety relay state is monitored as well. If the test result is not good, Err 24 is announced.

4.6.5 CHECKING THE CORRECT ACTIVITY OF THE SAFETY SYSTEM

Checking is performed after the required temperature reached the steady state (10 minutes at least) in the exposure phase. If you change the user safety temperature in U6, do not forget to record each temperature change in the safety system by **ON/OFF** pressing before leaving the user mode.

Temperature exceeding:

- Activate the user service, mode U6.
- Set the user safety upper temperature to a value exceeding the required one by $5\text{ }^{\circ}\text{C}$. The protective circuit must not react.
- Set the user safety upper temperature to a value $5\text{ }^{\circ}\text{C}$ below the required one. The protective circuit must react. The safety system indicator lights up and error Er13 is announced. In INCUCCELL, the safety system indicator lights up only.

CAUTION:

The safety system function differs according to the device type.

VENTICELL, ECOCELL and DUROCELL devices

If the maximum set permitted temperature in the chamber is exceeded, the safety system will switch off the heating elements and the safety system indicator lights up (the device does not heat although the heating indicator is lighting). Even if the temperature in the chamber drops below the set limit, the heating remains disconnected. To restart it, the button **X/W** must be held pressed. The device passes to the break state in which the parameters can be set or you can let the chamber cool. The device will be switched on by pressing **ON/OFF**.

Any event of temperature exceeding and error announcement is printed on a printer if connected.

Devices INCUCCELL and INCUCCELL with a ventilator

If the maximum set permitted temperature in the chamber is exceeded, the safety system will switch off the heating elements and the safety system indicator lights up (the device does not heat although the heating indicator is lighting). After the temperature in the chamber drops below the set limit, the heating is automatically switched on again. The safety system indicator will turn **OFF**. Any event of temperature exceeding and return is printed on a printer if connected.

4.7 LIST OF ERROR MESSAGES

When an error is displayed, you can switch to a textual description of the error, and/or other data displaying related to the error and recorded in the moment of the error occurrence. Use **▼▲** for switching. Leave this display by **X/W** pressing.

Er 11 – Wrong temperature sensor of the safety system

Contact the service centre.

Er13 – The temperature exceeds the user upper limit watched by the safety system.

Check the limit setting in the user mode U6: The limit may not be lower than the required temperature, taking also account of overshoot or fluctuation.

After you change the value, check by a repeated entry in the U6 mode whether the pre-set value has been saved. If not, check the correct setting procedure in the instructions for use.

Check also whether the device has not been overheated without the device fault, e.g. by the load ignition.

Er15 – The device threshold temperature watched by the safety system has been exceeded.

Check whether the device has not been overheated without the device fault, e.g. by the load ignition.

Er17 – The maximum phase time was exceeded

If there is any error during the temperature rise, compare the rise duration with the setting in the user mode 8 and/or assess the reasons for the long rise duration, or increase the maximum controlled period in mode U8.

Er23 – the temperature measured by the control system differs from the temperature measured by the safety system.

Check whether the error was not caused by strong temperature changes, e.g. by the door opening and air blowing.

Er24 - The safety relay did not pass the test

Contact the service centre.

Er 30 to Er 49 – Door blocking errors

See more in the chapter Two-Door Pass-through Model with Automatic Door Blocking

Er 50 and Er 51 – Wrong regulatory sensor

Contact the service centre.

Er 52 and Er 53 – Errors of flexible sensors

Check the integrity of the flexible sensor.

SEt tEMP CroSSEd SAFEtY USEr LIMIT.

Warning message informing only that the pre-set temperature is either lower or higher, but too close (up to 3 °C) to the user safety upper temperature checked by the safety system (U6), which probably will cause the safety system activation. Cancel the message by **X/W** pressing and change one of the two given values.

Hi ALARM

Lo ALARM

Alarm activation announcement. See the chapter ALARM FUNCTION

Other error messages

Disconnect the device from the power supply and then reconnect it.

If the error repeats, contact the service centre.

4.7.1 NOT DISPLAYED ERRORS

Red indicator with the safety thermostat symbol is lighting and the sound alarm is activated (intermittent tone). The safety system found that the set temperature had been exceeded. The error is not indicated; information on the display is normal.

Applies only to INCUCELL devices.

Check the setting between U6.

Red indicator with the safety thermostat symbol is lighting; the control unit does not react. The safety system switched off the safety. Disconnect the device from the power supply and reconnect relay; the heating elements have no current supply. Disconnect the device from the power supply and reconnect it.

The device does not show any information (the display is not lighting).

Check whether the device is connected to the electric power mains. If yes, try to disconnect and reconnect it.

The device does not react to any button.

Disconnect the device from the power supply and reconnect it.

The printer does not print, or prints some nonsense.

Check whether the device is switched to data sending to the printer (U3); check the print period (U1). Check whether the printer is connected to power supply and switched to the data transfer rate 9600 Bd.

The required temperature is overshoot a lot repeatedly during the exposure cycle and is reached only after some time.

Check whether the door and the device flap are closed properly.

The required temperature is exceeded a lot during the exposure cycle; the device stays overheated.

Switch the device off.

The required temperature is reached during the exposure cycle only after a too long time.

Check whether the door and the device flap are closed properly. Check whether the mains voltage reaches the values required by the Instructions for Use, chapter Mains Connection.

The temperature never reaches the required value during the exposure cycle.

Check whether the mains voltage reaches the values required by the Instructions for Use, chapter Mains Connection.

4.8 ADJUSTING AND FUNCTION OF THE AIR FLAP

Function description:

The air flap is intended for ventilating the chamber space of the unit, for example when drying wet materials.

Air flap adjustment:

Adjust the air flap when installing the unit. Put the control lever of the air flap to the closed position and adjust the air flap in the exhaust hole at the rear wall of the unit so that it closes the entire ventilating hole. Hold the shaft of the flap with pliers to prevent turning over.

Note:

With VENTICELL and INCUCELL WITH FAN it is necessary, in addition to the exhaust flap, to adjust the sucking air flap as well.

The air flap control:

If you put wet materials into the unit to dry it before tempering, put the air flap in the position open so that the humidity could freely leave the chamber. After finishing the drying put the air flap in the position closed.

Note:

Operating the unit with an open air-flap increases the power consumption and the maximum temperatures may not be reached.

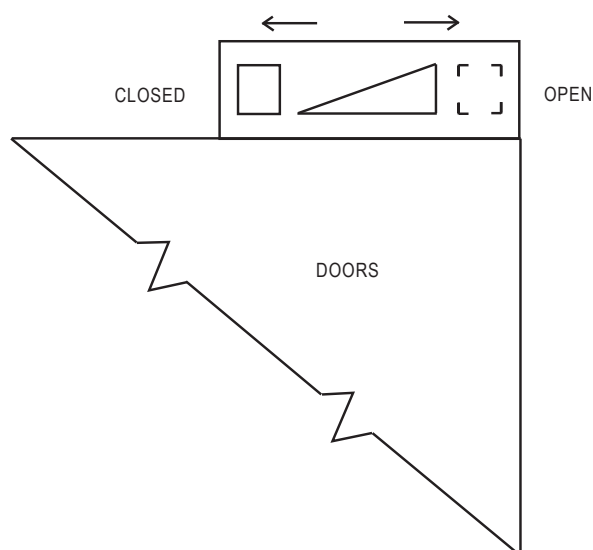

4.9 EXCHANGING THE DOOR SEALING AND ADJUSTING THE DOOR

Remove the sealing completely, start in the middle lower part.

Fix the new sealing on the edge of the chamber, start in the middle lower part. Squeeze the sealing between the chamber and the outer cover.

The door is adjustable at four points:

- in the left upper part by means of bolts and nuts – sketch position 3
- in the left lower part by means of bolts and nuts – sketch position 4
- in the right upper part by means of internal hexagon screw – sketch position 2
- in the right lower part after loosening the screw with internal hexagon adjusting in front-back direction of the door hinge is possible – sketch position 1.

In the apparatus of the volume of 22 there is only one adjustable screw in the side of the door locking device.

Adjust the door so that when closed the rubber sealing of the chamber would fit to the sheet of the floating door along the whole perimeter. To check it up place a sheet of paper between the sealing and the metal sheet of the floating door before it is closed, it is possible to take the paper out against a small resistance.

VENTICELL 22

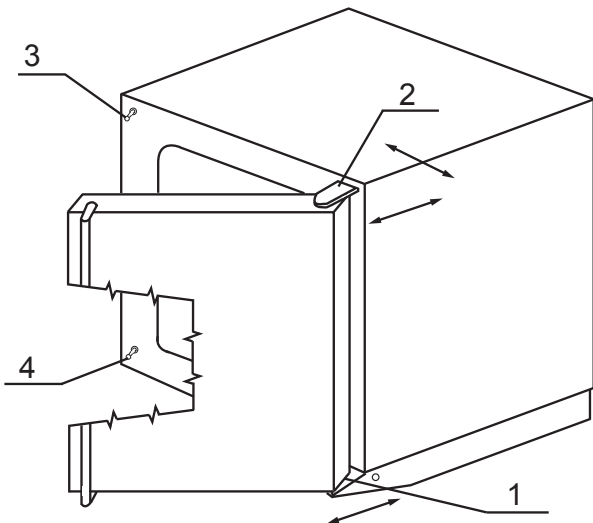
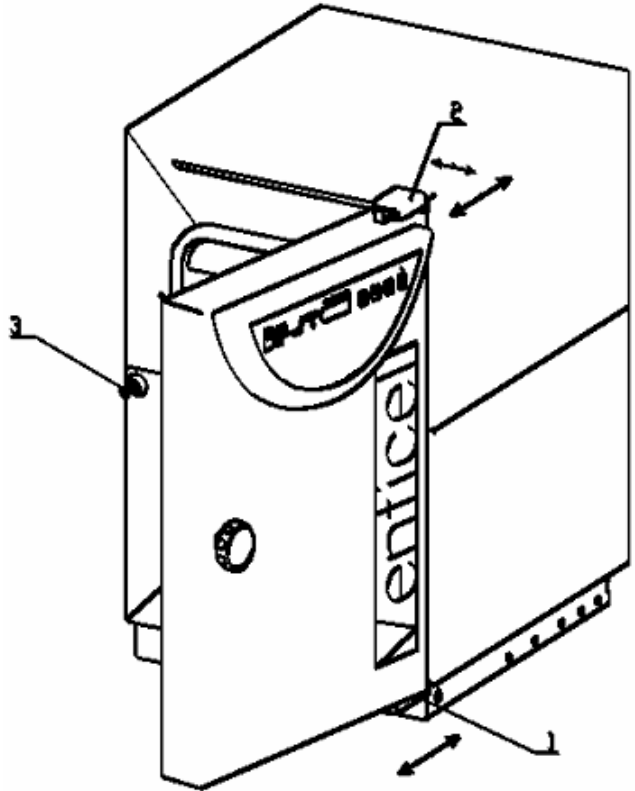

5 PARAMETERS OF THE UNIT

ECOCELL (EC), DUROCELL (DC), VENTICELL (VC), INCUCCELL/INCUCCELL V (IC/ICV)								
Technical data		volume EC, VC, IC / ICV	cca liters	22	55	111	222	
Interior of stainless steel material DIN No 1.4301		DC		22	55	111	222	
		width	mm	240	400	540	540	
		depth EC, DC, VC	mm	320	390	390	540	
		IC / ICV			370	370	520	
		height	mm	295	350	530	760	
Tray		bearing plate, width x depth	mm	185x265	380x335	520x335	520x485	
		racks	No	4	4	7	10	
		distance of the wiring	mm	60	70	70	70	
		standard equipment	pcs. included	2	2	2	2	
Maximal load		screens	kg/screen	10	20	20	30	
		steel sheet racks	kg/rack	10	20	20	30	
		in total	kg/case	25	50	50	70	
Door			psc.	1	1	1	1	
External dimensions (including door and handle)		width	mm	406	620	760	760	
		depth	mm	580	640	640	790	
		height (incl. Feet F and Rolls R)	mm	604F	680F	860F	1090F	
		Ø of the air branch outer / inner	mm	52/49	52/49	52/49	52/49	
Package dimensions (three layers carton)		width	mm	465	700	830	830	
		depth	mm	665	730	730	860	
		height (incl. palette)	mm	655	880	1050	1280	
Weight		nett	kg	31	55	75	100	
		brutt	kg	36	66	87	116	
Elektricity		power W input [stand by]		5	5	5	5	
- mains 50/60 Hz		max. power input kW	VC	0,96	1,3	1,9	1,9	
			DC	0,92	1,2	1,8	1,8	
			IC / ICV	0,24/0,96	0,3 / 0,7	0,3 / 0,7	0,5 / 0,7	
			EC	0,92	1,2	1,8	1,8	
		voltage V ****)	EC, DC, VC	230	230	230	230	
			IC / ICV	230	230	230	230	
		current A	VC	4,2	5,6	8,3	8,3	
			DC	4,0	5,2	8,3	7,8	
			IC/ICV	1,1 / 4,2	1,3 / 3	1,3 / 3	2 / 3	
			EC	4,0	5,2	7,8	7,8	
		voltage V ****)	EC, DC, VC	115	115	115	115	
			IC / ICV	115	115	115	115	
Temperature data		od 10 °C above ambient temp. to °C	VC **)	250 / 300	250 / 300	250 / 300	250 / 300	
Working temperature (beginning of the regulation)		od 5/10 °C above ambient temp. to °C	IC / ICV ***)	70 / 100	70 / 100	70 / 100	70 / 100	
		od 5 °C above ambient temp. to °C	EC	250	250	250	250	
			DC	125	125	125	125	
The temperature deviations***** according to DIN 12 880, Section 2, from the average value of the working temperature in the space of the chamber, when the ventilation flap and doors are closed		VC (>50 °C)	space deviation	cca (±) % Average value	1,1	1	1	
			time deviation	In the space of the chamber cca (±) °C	0,3	0,4	0,4	
		IC/ICV at 37 °C	space deviation	cca (±) °C	1,1/0,4	<0,5/≤0,3	<0,5/≤0,3	<1/≤0,3
			time deviation	do (±) °C	0,4/0,1	≤0,2	≤0,2	≤0,2
		EC	space deviation	cca (±) % Average value	2,7	2	2	
			time deviation	In the space of the chamber cca (±) °C	1,0	≤0,3	≤0,8	≤0,8
		DC at 100°C	space deviation	cca (±) % Average value	3,1	2	2	
			time deviation	In the space of the chamber cca (±) °C	0,4	≤0,3	≤0,8	≤0,8
Temperature rise time with closed air flap and at the voltage of 230 V ± 0V	250 °C	VC	cca min.	28	49	53	70	
		EC		54	59	60	99	
	100 °C	DC		34	41	48	50	
	37 °C	IC/ICV		70/8	49 / 41	57 / 51	79 / 66	
Heat emission at	250 °C	EC, VC	cca W	300 / 420	590	760	990	
	100 °C	DC		140	380	490	630	
	37 °C	IC/ICV		20/70	30	45	45	
Air exchange rate at	150 °C	VC	cca/h	45	45	49	24	
		EC		6	8	12	5	
	100 °C	DC		6	8	12	5	
		IC/ICV		4 / 45	5 / 45	5 / 49	5 / 24	

Note: All technical data are related to 22 °C ambient temperature and ± 10 % voltage swing (if not specified otherwise).

For other parameters see section 5.1 – Electric connections

*) Approx. 50 % of the tray area can be filled in a way a uniform air circulation is enabled inside the chamber.

***) Standard type is up to 250 °C, optional type is up to 300 °C

****) Supply voltage is indicated on the type table of the unit

+) Two-door open-through model, in Venticell only

****) Standard type is up to 70 °C, optional type is up to 99,9 °C

*****) Temperature deviations were measured in accordance with DIN 12 880

	222/2+	404	404/2+	707	707/2+
		-		-	-
	540	540	540	940	940
	540	540	540	540	540
		520		520	-
	760	1410	1410	1410	1410
	520x485	520x485	520x485	920x485	920x485
	10	19	19	19	19
	70	70	70	70	70
	2	2	2	2	2
	30	30	30	50	50
	30	30	30	20	20
	70	100	100	130	130
	2	1	2	2	4
	760	760	760	1160	1160
	790	790	790	790	790
	1110F	1910R	1910R	1910R	1910R
	52/49	52/49	52/49	52/49	52/49
	830	830	830	1230	1230
	860	860	860	860	860
	1280	2070	2070	2080	2080
	105	150	150	215	230
	121	175	185	240	255
	5	5	5	5	5
	3,7	3,7	5,5	4,9	7,2
		-		-	
		0,9 / 1,3		0,9 / 1,3	
		3,6		5,4	
	400/3NPE	400/3NPE	400/3NPE	400/3NPE	400/3NPE
		230		230	-
	5,2	5,2	7,9	7,8	10,4
		-		-	
		3,9 / 5,6		3,9 / 5,6	
		7,8		7,8	
	115/3PE	115/3PE	115/3PE	115/3PE	115/3PE
		115		230	-
	250 / 300	250 / 300	250 / 300	250 / 300	250 / 300
		70 / 100		70 / 100	-
		250		250	-
		-		-	-
	1	1,8	1,5	2,5	2,5
	0,4	0,9	0,4	0,4	0,74
		<1/≤0,8		<1,5/≤1,5	-
		≤0,2		≤0,2	-
		2,5		3,5	-
		≤1		≤1	-
		-		-	-
		-		-	-
	33	58	43	64	50
		85		95	-
		-		-	-
		41 / 38		59 / 51	-
	1300	1940	2400	2550	3300
		-		-	-
		65		85	-
	24	18	18	12	12
		4		3	-
		-		-	-
		5 / 18		5 / 12	-

5.1 ELECTRIC CONNECTIONS

Basic data for connection:	
Mains connection:	230V/50(60)Hz 400V/50(60)Hz, 3NPE; 115V/50(60)Hz; 115V/50(60)Hz, 3PE
(standard types are marked with bold face)	
Mains voltage fluctuation	±10 %
Protection against dangerous contact - class:	I
External circuits insulation	
double insulation	
The mains supply for the three-phase units must be ensured by a switch or circuit breaker which serves for disconnection. Such a switch or circuit breaker must be:	
<ul style="list-style-type: none"> - A component part of the building installation; - Placed in an immediate vicinity of the unit and accessible easily by the operator; - Labelled as the device disconnecting element; - Rated correctly and must comply with the requirements of the standards IEC 60947-1 and IEC 60947-3. 	
Protection according to EN 60529	IP 20
Overvoltage category according to (IEC 664 – EN 61010)	
II in case of pollution degree 2	
Used fuses:	according to corresponding diagrams in the Service instructions
Ambient conditions:	
- ambient temperature: +5 °C to +40 °C	
- max.relative humidity: 80% at the temperature up to 31 °C	
- maximal altitude: 3000 m	

6 CLEANING AND DECONTAMINATION OF THE UNIT

Clean the unit while cold and when the power supply cord is disconnected from the mains. Clean the interior walls of the chamber as well as the exterior of the unit with water and detergent, or possibly with suitable chemicals. Abrasive cleaning agents may scratch the metal sheets. If you want to clean the outer jacket of the chamber, take the inner walls of the chamber out as follows:

Shift the upper wall of the chamber out of the unit, take out the sidewalls, the bottom and the rear wall. Put the unit together in a reverse

sequence after it has been cleaned, be careful and slide in the bottom and the sidewalls as far as behind the four projections in the front part of the chamber.

In case some contaminated material has escaped into the chamber the user is responsible for proper decontamination of all contaminated surfaces with suitable and approved disinfecting agent.

Cases of volume 22 – EC, DC, IC:

Unbolt the screws in the back part of the ceiling and of the bottom of the chamber. By pulling out the walls in the direction to the door you release the walls and remove them from the apparatus. When you perform the assembly, you insert the front bend of the bottom under the holder of the heating radiator and lock the bottom with a screw. When you perform the assembly of the ceiling you put the back part on the sensor holder, put the front bend of the ceiling on the ceiling holder and lock with a screw.

(When you perform the assembly/disassembly of VC, ICV, use the identical procedure, after releasing the screw of the bottom, you tilt out the back wall.)

Before using some other cleaning or decontamination method different from our recommendation, it is suitable for the user to be informed by with the producer whether the intended method cannot cause damage to the device.

7 MAINTENANCE

No special maintenance is necessary. In case of any troubles, please, call the service.

Inspection of electric components:

The cases of thermal technique are destined for a basic/normal environment, the manufacturer recommends the inspection period of 1 year, if not determined by local regulations otherwise.

Inspection operations:

Inspection of the electrical installation, particularly of the electric power supply, of connecting terminals and a protective terminal.

Check the integrity of the conductor insulation (for example, due to wearing through, burning etc.) and the firm connection in the terminals. The resistance of the protective connection is < 0.1 Ohm, the resistance of the supply is not included.

If the case is placed in a different environment, the inspection must be performed in accordance with the local standards.

The service inspection is the matter of agreement between the client and the service organization.

8 WARRANTY AND SERVICE

The guarantee period is marked on the certificate of warranty.

The warranty refers to manufacturing defects or material defects on condition that:

- the product has been installed and used in accordance with the Instructions for use
- the cause of the defect was not a insufficient maintenance, unqualified intervention in the device or damage through external impacts.

The warranty does not relate to natural wear of material and to consumer material, such as e.g. door sealing, materials for recording devices, accumulators etc. If a defect occurs, draw claims to a warranty repair directly at the nearest MMM service center. Please mention the device name and type, its serial number and how the defect appears (error message, printer record). Provided the warranty conditions are fulfilled there follows, according to the consideration of the service center, the cost-free repair or replacement of the defective part.

If the prescribed maintenance is complied with, the device life exceeds 10 years. At the same time, this is the period for which the manufacturer bears objective responsibility within the meaning of EU Directive no. 85/374/EEC for any potential damage caused by the device operation. If you decide to continue using the device after the said period expiration, ask the manufacturer or an authorized service for an expertise whether or not the device can still be used regarding its wear and tear, technical condition and service availability.

9 TRANSPORT AND STORAGE

A competent person will prepare the unit for transport. The unit shall be transported and stored in its original package. If you send the device back (for repair or change in case of claim), use the original package. Otherwise

you take over the responsibility for possible damage during the transport and the producer will reclaim compensation for possible additional repairs. Device can be stored in the ambient temperatures from 0 °C to 40 °C.

10 THE WAY OF LIQUIDATION OF PACKAGE AND DISCARDED UNIT

Palette – Disposal at an incineration plant
Cardboard – Recyclable waste
Unit which was put out of operation:

For the European Union member states:

A product which the user stops to use and which becomes useless for the user and which



is labelled with a label  cannot be disposed of within the municipal waste. It is subject to a scheme corresponding to the national regulations relating liquidation of electric and electronic devices, complying with WEEE (Waste Electric and Electronic Equipment Directive) as amended. To liquidate the electric and electronic devices correctly, ask your seller or supplier for detailed information.

For other than European Union countries:

The above given symbol applies only to the European Union member countries. To liquidate the electric and electronic devices correctly, ask your authorities or the device seller for detailed information.

11 OPTIONAL EQUIPMENT

11.1 DOOR WITH WINDOW AND INNER LIGHTING (EXCEPT IC, ICV FOR ALL THE TYPES OF THE VOLUME OF 22)

The door is provided with three-layer thermally resistant windows; layout and dimensions are shown in the panorama picture at the next page.



Caution!

During operation of the cabinet do not touch the glass surface. This surface cannot be heat-insulated like the metal sheet door. Therefore the temperature of the glass surface is higher than that of other surfaces and there is a danger of burns. The inner space is illuminated with heat resistant bulbs – their switch is located on the door.

For types IC, ICV the door with window is not available.

The surface of the door with windows causes higher thermal losses, which increases spatial temperature deviations in the chamber (compared with common door without windows).

Door with glass windows (dimensions in mm)

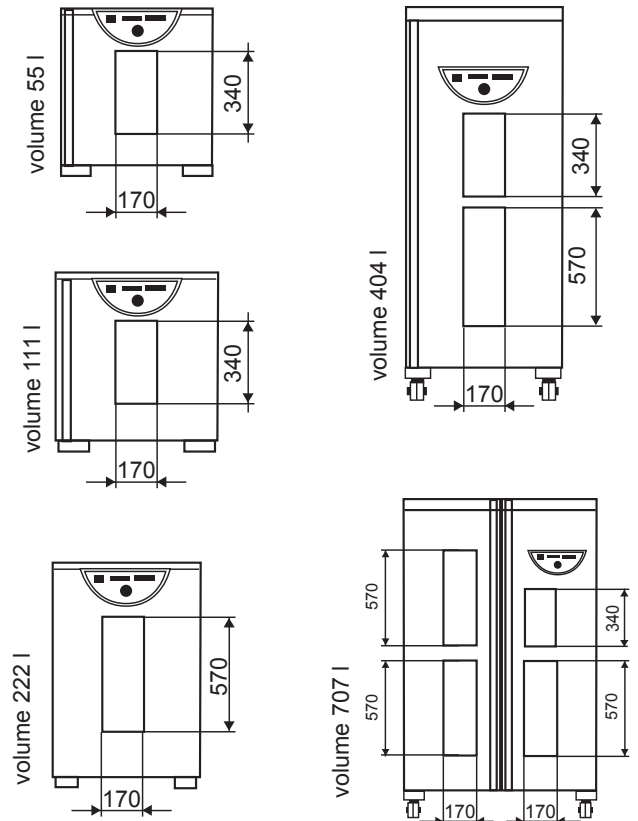

11.2 ACCESS PORTS OF DIAMETER 25, 50, 100 MM

The access ports are normally located approx. in the middle of the side (right or left) wall of the chamber. The exact position depends on the position of the heating elements. The access ports are metallic, closed with a special plastic plug from the outer side, which enables passing through of wires etc. from the outer space to the chamber.

Recommendation: The used unit should be provided with an access port with corresponding dimensions, if user wishes to measure temperature inside the chamber by means of sensors, connected with an independent measuring device by means of wires; the user shall run the wires through the access port.

Cases of the volume of 22 are equipped only with bushings 25 and 50.

11.3 LOCKABLE DOOR

The lock is located on the front door surface.

11.4 LEFT DOOR VERSION

This is a symmetric mirror version, the door can be opened to the other side. Except for 22 L volume.

11.5 FLEXIBLE PT 100 SENSOR

The other additional sensor, which is free movable inside the chamber, it is possible, with its help, to measure the temperature inside the chamber or inside the material. The temperature is displayed (according to the setting in the user mode) in the regular intervals on the display to the exclusion of displaying the regulation sensor temperature and it is distinguished from the regulation sensor by a vertical line on the left side of the display. Also the start of exposition is enabled (according to the setting in the service mode) from this sensor by reaching the same temperature as the requested temperature – 0,25 °C. (Together with the original prerequisite – reaching the temperature by the regulating sensor with the requested temperature – 0,05 °C).

11.6 SUPPORTIVE SW FOR PC

11.6.1 RECORDING SW - WARMCOMM - FOR PC UNDER WINDOWS

The program WarmComm is designed to record the temperature course in the ovens/incubators. Data obtained during the regulation are displayed in a diagram (with time on the horizontal axis and measured data on the vertical axis).

The program enables to follow the regulation on-line, to store the regulation course to a file on a disc and to view the already stored files, to send e-mails in case of not receiving data from the cabinet and to send reports of excessive values being reached within the specified time interval. The instructions for the programme use are supplied with the installation programme.

Hardware requirements: Common PC with an operational software Windows 2000, XP and higher. One free port RS 232 (COM) is required for each connected device. The maximum length of the connecting cable is 15 m.

16.6.2 RECORDING PRINTING SW - PRINTER ARCHIVE - FOR PC UNDER WINDOWS

The Printer Archive programme serves for text recording from the device print outlet. It serves as a direct substitution of a physical printer.

The data are recorded to a file on a PC disc and the programme offers more possibilities of the recorded data handling including archiving or printing on a table PC printer. Hardware requirements: Common PC with an operational software Windows 95 and higher. One free port RS 232 (COM) is required for each connected device. The maximum length of the connecting cable is 15 m. For more detailed information about HW, ask the seller.

11.7 HEPA FILTR

Available only in VENTICELL and INCUCCELL with a ventilator.

HEPA filter is either in a normal version or in the overpressure version. The overpressure HEPA filter is equipped with the external fan, which forces the surrounding air through the HEPA filter into the chamber and thus it ensures the overpressure in the chamber as opposed to the surrounding environment by ca. 20 Pa. In case of operation of the overpressure HEPA filter there may happen to deterioration of parameters of the thermal homogeneity.

Overpressure variant is pre-set in the user mode U13: Overpressure fan is available – “YES”/is not available – “NO”.

11.7.1 INSTALLATION OF HEPA FILTER, FILTER DIMENSIONS, FUNCTION AND FILTRATION CHARACTERISTIC OF THE AIR FILTER

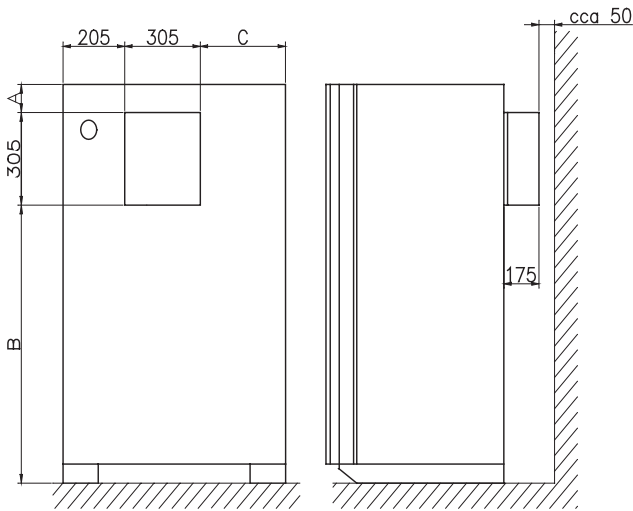
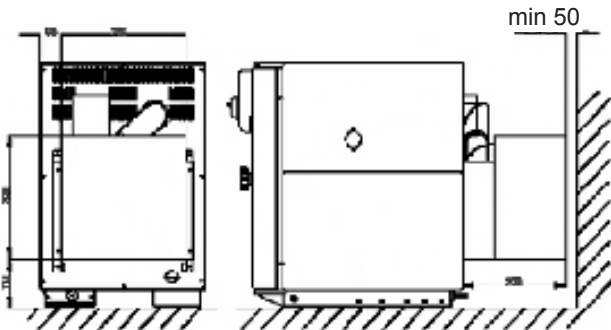

Fig. 3 (dimensions are in mm)

Type → Dimensions ↓	55	111	222	404	707
A (mm)	85	85	85	135	135
B (mm)	290	470	710	1470	1470
C (mm)	110	250	250	250	650
Height A+B+305(mm)	680	860	1100	1910	1910

Note: The minimum distance from the filter to the wall is 50 mm.

VENTICELL 22



Filter class is S (according to DIN 24 184), EU 12 (according to EUROVENT), or H13 (according to EN 1822).

HEPA filter installation

Insert nuts for HEPA filter attachment in four rectangular holes in the back cover of the device. Put the metal ring and two rubber rings on the suction flue. Slip the HEPA filter pipe on the flue. Fix the slipped HEPA filter by four screws. If the HEPA filter is provided by a ventilator, insert its plug in the power supply socket.

HEPA filter assembly to the apparatus of size 22:

- insert the supplied nuts into the holes in the rear wall (1/13)
- one metal ring and two rubber rings are put on the suction flue.
- put the air conduit on the suction chimney (2)
- put 2 pcs of O-rings on the air conduit, put the unit of HEPA filter on the air conduit and position it into a proper position
- fix it with a screw (1/12) and washer (1/15) to the rear wall
- connect the fan connector into the socket in the rear wall (only in case of the overpressure HEPA filter).

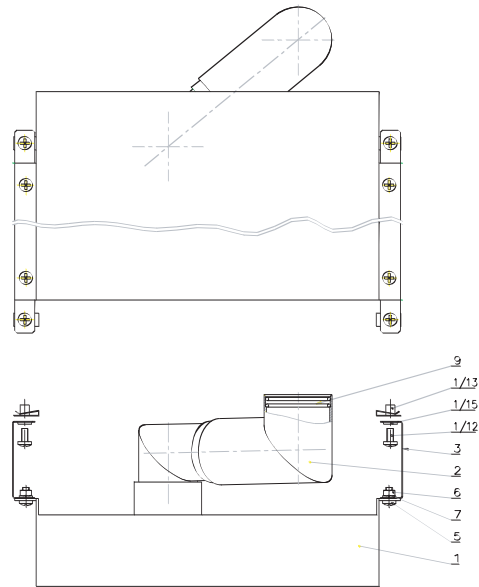

11.8 TWO-DOOR PASSING THROUGH VERSION

Available only in VC 222, 404 and 707. It makes possible to load the material in one space and its unload after thermal treatment in another space.

Through version of VENTICELL is equipped with super standard elements as follows:

- as an option - mechanical lock of the locking device of both doors,

- as a standard - micro switches of the locking devices of both doors – a display on the panels of both doors reports about the opening of whichever doors during the exposure with the message “open”.
- as a standard - LED chart on the panels of both doors informs about the active phase of the program.

This equipment helps to ensure a safe course of the sterilization.

11.8.1 VENTICELL 222/2 - INSTALLATION DATA

- 1) Input power 3700 W
- 2) Electrical installation – connection of the unit:
 - plug VDE 0623, DIN 4962/63in, CEE 17, IEC 309, 3P + N + PE, 16A/380-415 VAC
 - supply to the socket from the switchboard 5x2.5 mm² Cu, protection by circuit breaker 16 A – place near the unit
 - cable length 3 m.

Basic dimensional data are the same as in case of the following VC 404 / 2D – with the exception of the height – see the table of parameters. The case can be placed on the floor or on an individual customer’s support.

11.8.2 VENTICELL 404/2 – INSTALLATION DATA

- 1) Input power 5500 W
- 2) Electrical installation – connection of the unit:
 - plug VDE 0623, DIN 4962/63in, CEE 17, IEC 309, 3P + N + PE, 16A/380-415 VAC
 - supply to the socket from the switchboard 5x2.5 mm² Cu, protection by circuit breaker 16 A – place near the unit
 - cable length 3 m.

THE MAIN DIMENSIONS ARE FOR THE TWO-DOOR VENTICELL 404;
THE DIFFERENT DATA IN BRACKETS APPLY TO THE TWO-DOOR VENTICELL 222

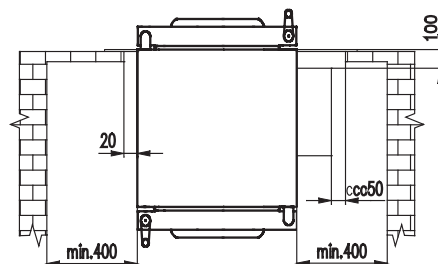
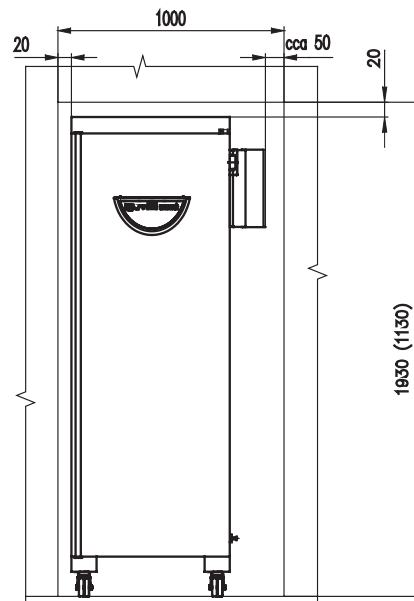
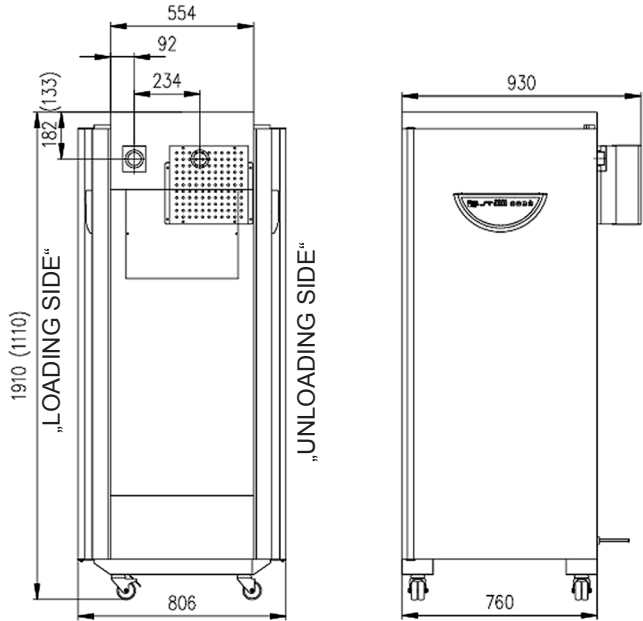

11.8.3 VENTICELL 707/2 – INSTALLATION DATA

- 1) Input power 7200 W
- 2) Electrical installation – connection of the unit:
 - plug VDE 0623, DIN 4962/63in, CEE 17, IEC 309, 3P + N + PE, 16A/380-415 VAC
 - supply to the socket from the switchboard 5x2.5 mm² Cu, protection by circuit breaker 16 A – place near the unit
 - cable length 3 m.

DIMENSIONS OF VENTICELL 707 - PASSING THROUGH (proportions in mm)

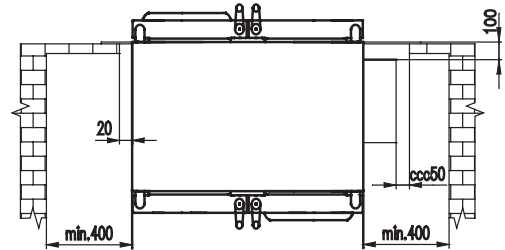
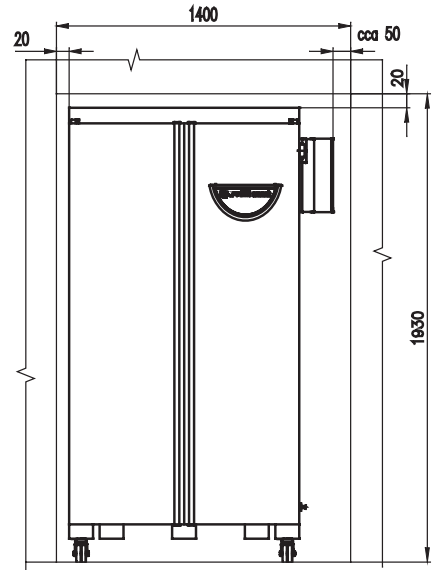
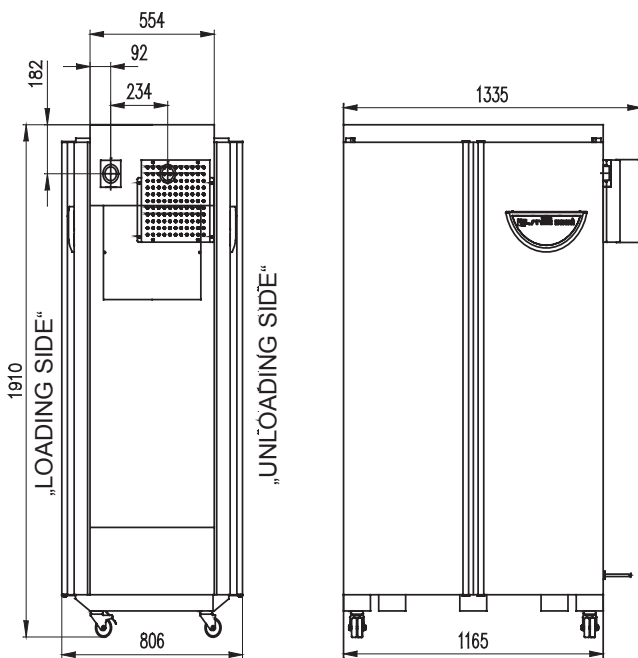

COVER SHEETS

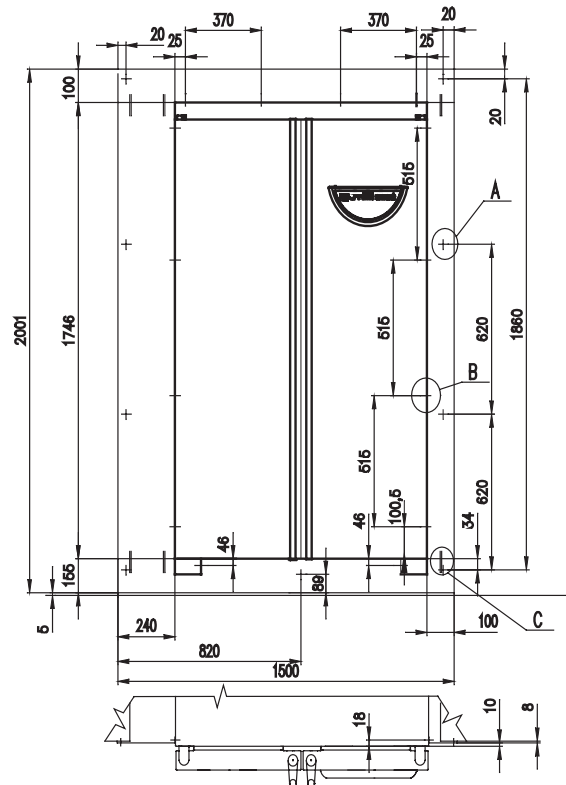

Detail A

8x (6x) (5x) screw \varnothing 4x40 with countersink head with cross groove for fixing to a wall insert dowels with a size of 8 to the wall.

Detail B

15x (19x) (15x) screw for a metal sheet \varnothing 3,9x9 with a half-round head and a cross groove necessary to screw with cover sheets with holes of \varnothing 3.2

Detail C

By beating the pins to the rectangular holes of the sheet borders secure them together.

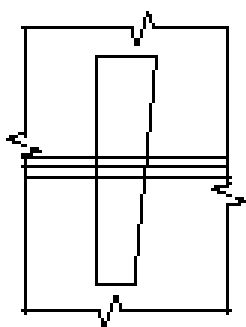

11.8.4 DOUBLE-DOOR THROUGH VERSION WITH AUTOMATIC DOOR BLOCKING

An electrically controlled mechanism is used in this version, which prevents the simultaneous opening of both doors. The mechanism stays in its position also when the device is switched off. The initial state, when is blocked the door on the input side, could be initiated at the moment of the end of exposition phase by the output door switch, or by the same switch in the break phase – after the failure. This state is determined for the charge inserting and it lasts for the whole exposition time. At the end of the exposure phase, the device passes to the state of unblocked door on the unloading side on condition that the exposure passed through successfully (the “end” sign is displayed). But, this is not valid, if the sterilisation has run with the opened valve or door and the inscription “open” is displayed on the display. In this case, it is necessary to start the exposition again by the **ON/OFF** button. In the “exposition end” phase, the door could be opened only on the output side. If the valve is opened during this phase, the operating personal is warned by an acoustic alarm and the inscription “open” is displayed. After the material is taken out and the door is closed, the operator at the unloading side presses the button on the control panel. At this

moment, the door is blocked on the output side and unblocked on the input side. Simultaneously with this change, the VENTICELL converts from the End phase into the StandBy phase. (The re-blocking could be also made after switching out the device by the **ON/OFF** button in the StandBy phase.)

Subsequent cycle can be then started by means of **ON/OFF** button. Positions of blocking servomechanisms are tested continuously and error is displayed if the position is not correct.

! WARNING!

It is not allowed the force opening of the blocked door. The blocking system could be mechanically damaged.

In case of emergency door opening necessity (e.g. mains breakdown), follow the instructions in the Emergency door-opening annex.

11.8.5 DOOR BLOCKING ERRORS

Er30 to Er37 Blocking or unblocking failed (odd numbers are for the unloading door, even numbers for the loading door)

Prepare the device to passage to the initial state by both door closing (remove mechanical obstacles, if any). After you close the door, press the button “Block the unloading side”. Start a new cycle by pressing the **ON/OFF** button.

Er39 The loading door is opened at the end of exposure

Prepare the device to transfer to the initial state. Check whether the loading door is not really opened. Close all the doors (remove mechanical obstacles, if any). After you close the door, press the button “Block the unloading side”. Start a new cycle by pressing the **ON/OFF** button.

Er40 to Er47 Incorrect position of the blocking mechanism (odd numbers are for the unloading door, even numbers for the loading door)

See Er30 to Er37.

11.9 ANTI-DRY MODIFICATION FOR CULTIVATING MEDIUMS AND TISSUE CULTURES

This mechanical and program adaptation reduces considerably the drying-up of cultivating mediums and tissue cultures when using INCUCELL with a fan. Basically there is increased the chamber tightness, it is not possible to open the valves of air holes, there is a humidity tray added, the ventilator turns off when the door is opened.

11.10 NO-POTENTIAL CONTACT – ALARM

The no-potential contact is connected in case the user alarm or the safety system warning (IC, ICV) have been activated, or the device error state has been activated by any error Err. The no-potential contact is used for passing the information about the described problems to another supervising system or to a signalling label without any electric intervention in the device circuits.

12 EMERGENCY DOOR OPENING

(use it only in case of failure or power failure).

1. To insert a thin object (screwdriver, rod etc.) through the air hole of the door (in the bottom door surface) under the angle of ca 45 ° in the distance of ca 90 mm from the door edge.

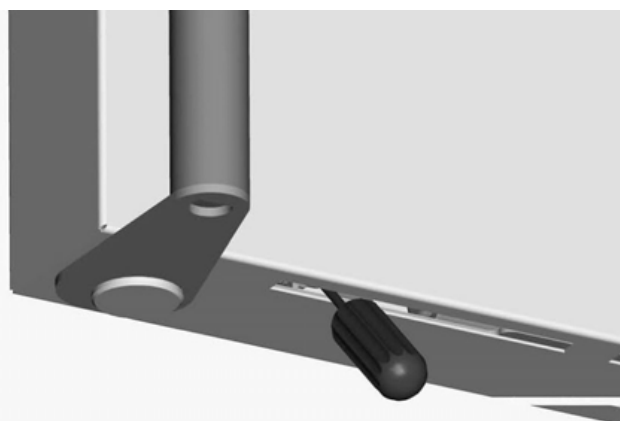
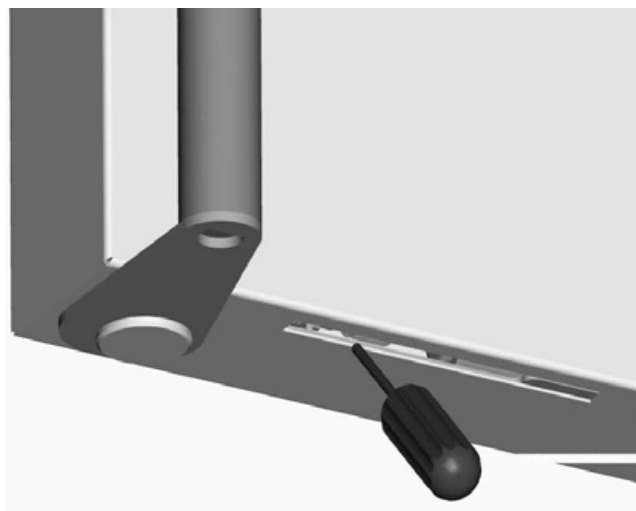

2. To push in the arrow direction and thus to push away the blocking rod (10 -15 mm is enough). In case of standard model – of the right door in the arrow direction, in case of the non-standard model – of the left door – it would be reversely (always in the direction from handle to the door hinges).

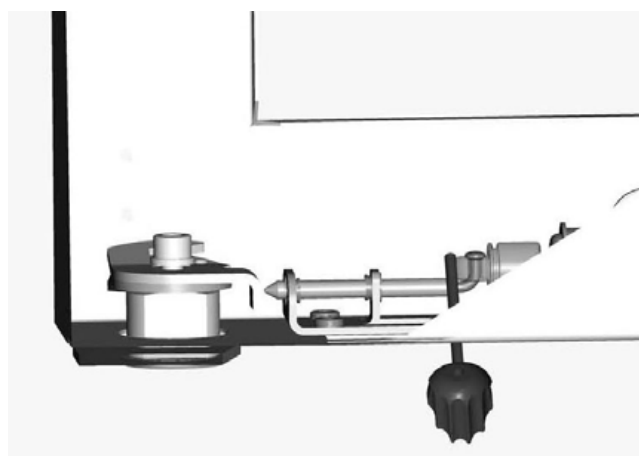

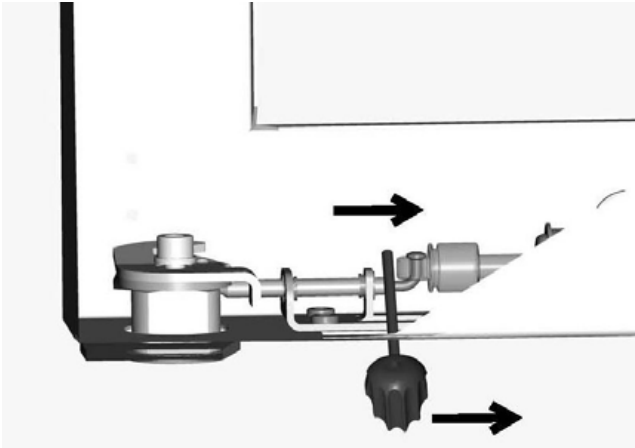

3. To open the door by means of the door handle
If it would be not possible to move away the blocking rod of the door – see above, then it would be necessary to unscrew the whole blocking mechanism underneath (4x M4 screws) and to push it away as a whole. After such intervention, the service work is necessary (backward blocking mechanism assembly).



EC-DECLARATION OF CONFORMITY



Date 2012-06-09	European Directive 2006/95/EC, 2004/108/EC
---------------------------	--

Manufacturer

MMM Medcenter Einrichtungen GmbH, Semmelweisstrasse 6, D-82152 Planegg / München

declare on our own responsibility that product

heating oven:	electrically heated drying oven intended for heating of laboratory materials in the temperature range up to 300 °C
trade name:	VENTICELL, ECOCELL, DUROCELL, INCUCCELL, INCUCCELL V
type:	LSIS-B2V, LSIK-B2V
model:	VC kkk, VC kkk/2, EC kkk, EC kkk/2, DC kkk, DC kkk/2, IC kkk, IC kkk/2, ICV kkk, ICV kkk/2 kkk (volume): 22, 55, 111, 222, 404, 707

meets all the provisions of the Directives no. 2006/95/EC, 2004/108/EC, which apply to him.

This declaration is valid for all of the above products, that are marketed after the date of issue and is valid until changes in the facts contained therein.

Standards applied:

EN 61010-1:2001	Safety requirements for electrical equipment for measurement, control and laboratory use - Part 1: General requirements
EN 61010-2-010:2003	Safety requirements for electrical equipment for measurement, control and laboratory use - Part 2-010: Particular requirements for laboratory equipment for the heating of material
EN 61326-1:2006	Electrical equipment for measurement, control and laboratory use - EMC requirements Part 1: General requirements

Ing. Milan Krajcar
executive
jednatel



... excellence
in medical and laboratory
engineering

Manufactured in the EU



MMM Medcenter Einrichtungen GmbH
Sommelweisstrasse 6
D-82152 Planegg
Germany

T. +49 89 89 92 26 20
F. +49 89 89 92 26 30
e-mail: medcenter@mmmgroup.com